

3/8" to 1/4" coupler

NF ISO 3316, ISO 3316, DIN 3123, ASME B107.10

- For adapting 1/4" drive sockets.
- Max. torque 62 N.m.
- Finish: bright chrome.

	d [mm]	L [mm]	L1 [mm]	ΔΔ [g]
J.230	17,5	24,5	17	25

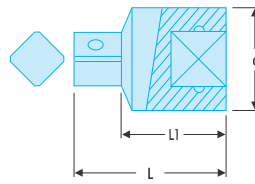

3/8" to 1/2" coupler

NF ISO 3316, ISO 3316, DIN 3123, ASME B107.10

- For adapting 1/2" drive sockets.
- Finish: bright chrome.

	A [mm]	d [mm]	L [mm]	L1 [mm]	ΔΔ [g]
J.232	16,5	18	34,5	19	45

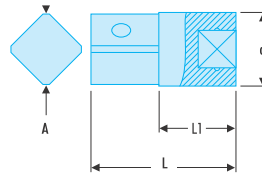

Set of 3 couplers

- Allows use of square drivers smaller than socket drive sizes:
 - 1/4" square drive + D.169RJ --> 3/8" socket.
 - 3/8" square drive + D.169JS --> 1/2" socket.
 - 1/2" square drive --> 3/4" socket.
- Compactness means that fewer tools are needed for in situ maintenance operations.
- Magnetic retainer and locking system (JS and SK).
- Knurl allows hand tightening where access is difficult.

	ΔΔ [g]
D.169	100



J - 3/8" bit holder sockets with retaining clip

NF ISO 2725-1, NF ISO 1173, ISO 2725-1, ISO 1173, DIN 3124

- Spring clip for frequent bit changes.
- For frequent removals.
- Finish: bright chrome.
- J.235: 1/4 bits.
- J.236: 5/16 bits.

	A ["]	d [mm]	d1 [mm]	L [mm]	Square ["]	ΔΔ [g]
J.235	1/4	18,0	11,311,3	30	3/8	28
J.236	5/16	18,0	14,0,0	30	3/8	30

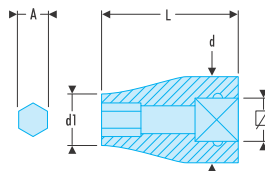

3/8" bit holder socket with locking ring

NF ISO 2725-1, NF ISO 1173, ISO 2725-1, ISO 1173, DIN 3124

- Bit lock.
- Square drive has side-hole for ball or plunger lock.

	A ["]	L [mm]	Square ["]	ΔΔ [g]
EF.J	1/4	43	3/8	50



SOCKETS 3/8"

J.H - 3/8" metric 6-point sockets

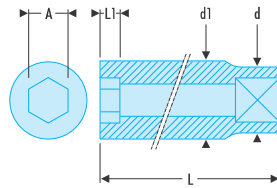

NF ISO 2725-1, NF ISO 1711-1, ISO 2725-1, ISO 1711-1, DIN 3124, ASME B107.5

- OGV® profile: more powerful tightening, preserves fasteners.
- Finish: bright chrome.

Socket	A [mm]	d [mm]	d1 [mm]	L [mm]	L1 [mm]	6 [mm]	ΔΔ [g]
J.7H	7	17,6	11,0	27	6,0	6	24
J.8H	8	17,6	12,2	27	6,5	6	25
J.9H	9	17,6	13,5	27	6,7	6	25
J.10H	10	17,6	14,7	27	7,8	6	26
J.11H	11	17,6	16,0	27	9,0	6	27
J.12H	12	17,6	17,2	27	9,5	6	26
J.13H	13	17,4	18,3	30	10,4	6	36
J.14H	14	17,6	19,5	30	10,5	6	34
J.15H	15	18,9	20,8	30	12,0	6	38
J.16H	16	19,9	22,0	30	12,0	6	45
J.17H	17	21,7	23,4	30	13,0	6	52
J.18H	18	21,7	24,7	33	13,0	6	69
J.19H	19	22,7	26,0	33	14,0	6	62
J.20H	20	22,2	27,2	33	15,0	6	70
J.21H	21	23,5	28,5	33	16,0	6	75
J.22H	22	24,7	29,7	33	16,5	6	80
J.23H	23	26,0	31,0	33	16,5	6	90
J.24H	24	26,3	31,3	33	16,5	6	86

J - 3/8" metric 12-point sockets

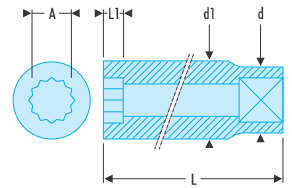

NF ISO 2725-1, NF ISO 1711-1, ISO 2725-1, ISO 1711-1, DIN 3124, ASME B107.5

- OGV® profile: more powerful tightening, preserves fasteners.
- Finish: bright chrome.

Socket	A [mm]	d [mm]	d1 [mm]	L [mm]	L1 [mm]	12 [mm]	ΔΔ [g]
J.7	7	17,6	11,0	27	6,0	12	24
J.8	8	17,6	12,2	27	6,5	12	25
J.9	9	17,6	13,5	27	6,7	12	25
J.10	10	17,6	14,7	27	7,8	12	26
J.11	11	17,6	16,0	27	9,0	12	27
J.12	12	17,6	17,2	27	9,5	12	26
J.13	13	17,5	18,3	30	10,4	12	36
J.14	14	17,7	19,5	30	10,5	12	34
J.15	15	19,0	20,8	30	12,0	12	38
J.16	16	20,0	22,0	30	12,0	12	45
J.17	17	21,7	23,4	30	13,0	12	52
J.18	18	21,7	24,7	33	13,0	12	69
J.19	19	22,7	26,0	33	14,0	12	62
J.20	20	22,2	27,2	33	15,0	12	70
J.21	21	23,5	28,5	33	16,0	12	75
J.22	22	24,7	29,7	33	16,5	12	80
J.23	23	26,0	31,0	33	16,5	12	90
J.24	24	26,3	31,3	33	16,5	12	86

J - 3/8" inch 12-point sockets

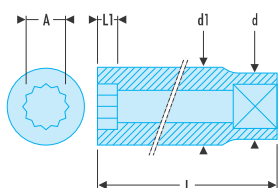

ASME B107.1

- OGV® profile: more powerful tightening, preserves fasteners.
- Available as rack sets (Ref J.40U).
- Finish: bright chrome.

Socket	A ["]	d [mm]	d1 [mm]	L [mm]	L1 [mm]	12 [mm]	ΔΔ [g]
J.1/4	1/4	17,5	10,0	27	6,0	12	24
J.5/16	5/16	17,5	11,9	27	6,5	12	25
J.3/8	3/8	17,6	14,1	27	7,5	12	26
J.7/16	7/16	17,5	16,0	27	9,0	12	27
J.1/2	1/2	17,5	18,1	30	10,4	12	36
J.9/16	9/16	17,7	19,5	30	10,5	12	34
J.5/8	5/8	20,0	22,0	30	12,0	12	46
J.11/16	11/16	21,0	24,0	33	13,0	12	74
J.3/4	3/4	22,7	26,0	33	14,0	12	76
J.13/16	13/16	23,0	28,0	33	16,0	12	79
J.7/8	7/8	24,7	29,7	33	16,5	12	104
J.15/16	15/16	26,3	31,3	33	16,5	12	136
J.1P	1	28,3	33,3	33	16,5	12	156

■ **JB - 3/8" inch 12-point sockets**



ASME B107.1

- OGV® profile: more powerful tightening, preserves fasteners.
- Built to aeronautical specifications.
- Finish: bright chrome.



Ref	A ["]	d [mm]	d1 [mm]	L [mm]	L1 [mm]	12 [mm]	ΔΔ [g]
JB.1/4	1/4	16,7	9,7	27	6,0	12	20
JB.5/16	5/16	16,7	11,7	27	6,8	12	21
JB.11/32	11/32	16,7	12,7	27	6,8	12	22
JB.3/8	3/8	16,7	13,7	27	7,5	12	23
JB.7/16	7/16	16,7	15,6	27	9,0	12	24
JB.1/2	1/2	16,7	17,6	30	10,4	12	27
JB.9/16	9/16	18,5	19,6	30	10,5	12	33
JB.5/8	5/8	20,0	21,6	30	12,0	12	42
JB.11/16	11/16	22,0	23,6	32	13,0	12	50
JB.3/4	3/4	22,8	25,4	32	15,0	12	55
JB.13/16	13/16	24,0	27,4	32	16,0	12	68
JB.7/8	7/8	24,0	29,4	32	16,0	12	68

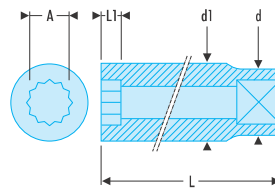

■ **J.HLA - 3/8" long-reach metric 6-point sockets**



NF ISO 2725-1, NF ISO 1711-1, ISO 2725-1, ISO 1711-1, DIN 3124, ASME B107.5

- OGV® profile: more powerful tightening, preserves fasteners.
- Long-reach sockets for long recess or thread access.
- Available as rack set Ref JL.40E (7 --> 15 mm) and Ref RL.41E (16 --> 24 mm).
- Finish: bright chrome.



Ref	A [mm]	d [mm]	d1 [mm]	L [mm]	L1 [mm]	6 [mm]	ΔΔ [g]
J.7HLA	7	17,3	10,6	55	6,0	6	44
J.8HLA	8	17,3	12,0	55	7,5	6	46
J.9HLA	9	17,3	13,0	55	7,5	6	47
J.10HLA	10	17,3	14,5	55	9,0	6	50
J.11HLA	11	17,3	16,0	55	10,5	6	53
J.12HLA	12	17,2	16,8	55	12,0	6	53
J.13HLA	13	17,0	18,0	55	12,0	6	54
J.14HLA	14	18,0	20,0	55	15,0	6	60
J.15HLA	15	20,0	21,0	60	15,0	6	75
J.16HLA	16	20,0	22,0	60	15,0	6	85
J.17HLA	17	22,0	23,5	60	15,0	6	102
J.18HLA	18	23,0	24,5	60	18,0	6	109
J.19HLA	19	24,0	25,0	60	18,0	6	110
J.21HLA	21	26,0	27,0	60	18,0	6	123
J.22HLA	22	28,0	29,0	60	21,0	6	150
J.24HLA	24	30,0	31,0	60	24,0	6	176

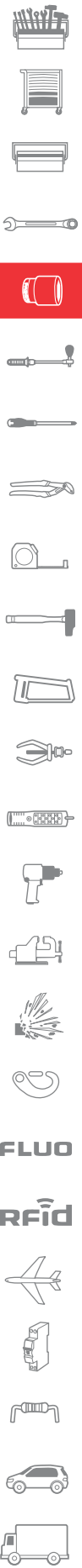
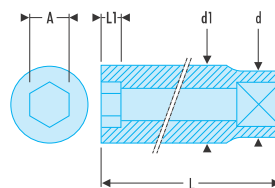

SOCKETS 3/8"

J.LA - 3/8" long-reach metric 12-point sockets

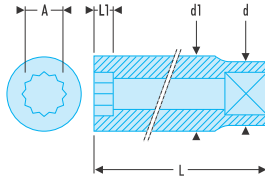

NF ISO 2725-1, NF ISO 1711-1, ISO 2725-1, ISO 1711-1, DIN 3124, ASME B107.5

- OGV® profile: more powerful tightening, preserves fasteners.
- Long-reach sockets for long recess or thread access.
- Available as rack sets (Ref JL.40U).
- Finish: bright chrome.

Ref	A [mm]	d [mm]	d1 [mm]	L [mm]	L1 [mm]	12 [mm]	ΔΔ [g]
J.7LA	7	17,3	10,6	55	6,0	12	44
J.8LA	8	17,3	12,0	55	7,5	12	46
J.9LA	9	17,3	13,0	55	7,5	12	47
J.10LA	10	17,3	14,5	55	9,0	12	50
J.11LA	11	17,3	16,0	55	10,5	12	53
J.12LA	12	17,3	16,8	55	12,0	12	53
J.13LA	13	17,2	18,0	55	12,0	12	54
J.14LA	14	17	20,0	55	15,0	12	60
J.15LA	15	18	21,0	55	15,0	12	75
J.16LA	16	20	22,0	60	15,0	12	85
J.17LA	17	20	23,5	60	15,0	12	102
J.18LA	18	22	24,5	60	18,0	12	109
J.19LA	19	23	25,0	60	18,0	12	110
J.21LA	21	24	27,0	60	18,0	12	123
J.22LA	22	26	29,0	60	21,0	12	150
J.24LA	24	30	31,0	60	21,0	12	176

J.LA - 3/8" inch 12-point sockets

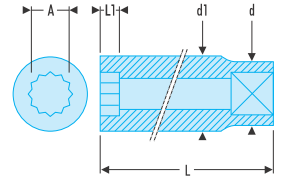

ASME B107.1

- OGV® profile: more powerful tightening, preserves fasteners.
- Long-reach sockets for long recess or thread access.
- Finish: bright chrome.

Ref	A ["]	d [mm]	d1 [mm]	L [mm]	L1 [mm]	12 [mm]	ΔΔ [g]
J.1/4LA	1/4	17,5	10,6	44,7	4,0	12	36
J.5/16LA	5/16	17,5	12,4	44,7	4,3	12	36
J.3/8LA	3/8	17,5	14,3	44,7	4,7	12	41
J.7/16LA	7/16	17,5	16,2	44,7	6,2	12	45
J.1/2LA	1/2	18,2	18,2	44,7	7,4	12	50
J.9/16LA	9/16	20,5	20,5	48,0	9,0	12	72
J.5/8LA	5/8	22,3	22,3	63,8	10,2	12	104
J.11/16LA	11/16	23,8	23,8	63,8	10,2	12	113
J.3/4LA	3/4	25,3	25,3	63,8	11,8	12	127
J.13/16LA	13/16	27,0	27,0	63,8	12,3	12	140
J.7/8LA	7/8	30,2	30,2	63,8	12,7	12	181
J.15/16LA	15/16	31,8	31,8	63,8	12,7	12	185
J.1PLA	1	33,4	33,4	63,8	12,7	12	185

Sets of 3/8" sockets in metallic rack



Ref	A ["]	A [mm]	6 12 [mm]	Torx [No]	Contents	Qtés	ΔΔ [kg]
J.40E		J. 7 - 8 - 9 - 10 - 11 - 12 - 13 - 14 - 15 - 16	12		CKS.94	10	0,380
JL.40E		J.LA 7 - 8 - 9 - 10 - 11 - 12 - 13 - 14 - 15	12		CKS.94	9	0,615
JL.41E		J.LA 16 - 17 - 18 - 19 - 21 - 22 - 24	12		CKS.94	7	0,975
J.40U	J. 1/4 - 5/16 - 3/8 - 7/16 - 1/2 - 9/16 - 5/8 - 11/16		12		CKS.94	8	0,365
JL.40U	J. 1/4 - 5/16 - 3/8 - 7/16 - 1/2 - 9/16 - 5/8 - 11/16		12		CKS.94	10	0,850
JTX.40				TORX®	JTX. E8 - E10 - E12 - E14 - E16	5	0,350
JT.40		JT. 4 - 5 - 6 - 7 - 8 - 10	6		CKS.91	6	0,305

J - 3/8" socket set in box



Box BP.MBOXM.

Ref	A [mm]	Contents	Qtés	ΔΔ [kg]
J.400	J. 7 - 8 - 9 - 10 - 11 - 12 - 13 - 14 - 15 - 16 - 17 - 18 - 19 - 21 - 22 - 23 - 24	PL.M20	17	1,540
J.401	J.H 7 - 8 - 9 - 10 - 11 - 12 - 13 - 14 - 15 - 16 - 17 - 18 - 19 - 21 - 22 - 23 - 24	PL.M20	17	1,540
J.404	J.LA 7 - 8 - 9 - 10 - 11 - 12 - 13 - 14 - 15 - 16 - 17 - 18 - 19 - 21 - 22 - 24	PL.M21	16	2,150
J.405	7 - 8 - 9 - 10 - 11 - 12 - 13 - 14 - 15 - 16 - 17 - 18 - 19 - 21 - 22 - 24	PL.M21	16	2,150

■ **J.F - 3/8" drive hinged inch 12-point sockets**

ASME B107.1

- OGV® profile: more powerful tightening, preserves fasteners.
- Compact solution used instead of universal joint.
- Finish: bright chrome.

⇒	A ["]	d [mm]	d1 [mm]	L [mm]	L1 [mm]	12 [mm]	ΔΔ [g]
J.3/8F	3/8	19	14,0	27	8,3	12	26
J.7/16F	7/16	19	15,8	27	9,8	12	27
J.1/2F	1/2	19	18,3	30	11,3	12	36
J.9/16F	9/16	19	19,5	30	11,3	12	34
J.5/8F	5/8	19	22,00	30	12,8	12	46
J.11/16F	11/16	19	24,00	33	13,8	12	74
J.3/4F	3/4	19	25,8	33	15,8	12	76

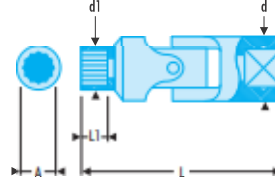

TORX® SOCKETS 3/8"

■ **JTX - 3/8" Torx® sockets**

- For Torx® fasteners.
- Available as metal rack set (Ref JTX.40).
- Finish: bright chrome.

⇒	A [mm]	d [mm]	d1 [mm]	L [mm]	L1 [mm]	Torx [No]	ΔΔ [g]
JTX.8	7,29	17,3	9,9	26	5,6	E8	40
JTX.10	9,19	17,3	11,8	26	6,4	E10	40
JTX.12	10,95	17,3	14,5	26	8,0	E12	40
JTX.14	12,67	17,3	15,7	26	8,8	E14	50
JTX.16	14,70	17,3	18,0	26	9,6	E16	100

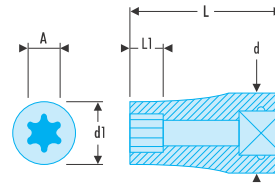

SCREWDRIVER SOCKETS 3/8"

■ **JT - 3/8" drive metric bit sockets**

- Removable bits.
- J.235 socket.
- Finish: bright chrome with phosphate-hardened tip.
- Available as rack set Ref JT.40.

⇒	A [mm]	d [mm]	L [mm]	L1 [mm]	Socket	Bits	ΔΔ [g]
JT.3	3	18	45,0	15,0	J.235	EH.103	31
JT.4	4	18	45,0	15,0	J.235	EH.104	31
JT.5	5	18	45,0	15,0	J.235	EH.105	32
JT.6	6	18	45,0	15,0	J.235	EH.106	33
JT.7	7	18	45,0	15,0	J.235	EH.107	34
JT.8	8	18	47,5	17,5	J.236	EH.208	43
JT.10	10	18	47,5	17,5	J.236	EH.210	50

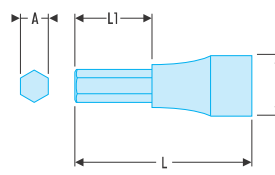







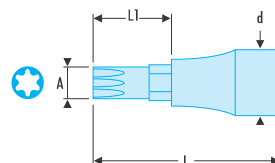



■ **JX - 3/8" Torx® drive sockets**

- Removable bits.
- J.236 socket.
- Finish: bright chrome with phosphate-hardened tip.

⇒	A [mm]	L [mm]	L1 [mm]	Torx [No]	Socket	Bits	No.	ΔΔ [g]
JX.10	2,72	46,0	16,0	T10	J.235	EX.110	T10	34
JX.15	3,26	46,0	16,0	T15	J.235	EX.115	T15	34
JX.20	3,84	46,0	16,0	T20	J.235	EX.120	T20	34
JX.25	4,40	46,0	16,0	T25	J.235	EX.125	T25	34
JX.27	4,96	46,0	16,0	T27	J.235	EX.127	T27	34
JX.30	5,49	46,0	16,0	T30	J.235	EX.130	T30	34
JX.40	6,60	52,5	22,5	T40	J.236	EX.240	T40	45
JX.45	7,77	52,5	22,5	T45	J.236	EX.245	T45	45
JX.50	8,79	52,5	22,5	T50	J.236	EX.250	T50	18
JX.55	11,17	52,5	22,5	T55	J.236	EX.255	T55	61



SETS OF 1/2" METRIC 'DETECTION BOX' SOCKETS

		S.161DBOX1	SL.DBOX1	SL.DBOX112	SL.DBOX500	SL.DBOX501	S.360DBOX1	S.360DBOX112	SXL.DBOX1
  Socket		S.161B	SL.161	SL.161	SL.171	SL.171	S.360	S.360	SXL.161
		Standard	Standard	Standard	Standard	Standard	Standard	Standard	Standard
 mm	8	•	•	•	•	•	•	•	•
	9								
	10	•	•	•	•	•	•	•	•
	11	•	•	•	•	•	•	•	•
	12	•	•	•	•	•	•	•	•
	13	•	•	•	•	•	•	•	•
	14	•	•	•	•	•	•	•	•
	15	•	•	•	•	•	•	•	•
	16	•	•	•	•	•	•	•	•
	17	•	•	•	•	•	•	•	•
	18	•	•	•	•	•	•	•	•
	19	•	•	•	•	•	•	•	•
	21	•	•	•	•	•	•	•	•
	22	•	•	•	•	•	•	•	•
23									
24	•	•	•	•	•	•	•	•	
27	•	•	•	•	•	•	•	•	
30	•	•	•	•	•	•	•	•	
32	•	•	•	•	•	•	•	•	
 S.210		•	•	•					
 S.215		•	•	•					
 S.210RC					•	•			
 S.215RC					•	•			
 S.210S								•	
 S.240A		•	•	•			•	•	
 S.120A									
 BV.S1NANO									
		340 x 180 x 58 mm							
		3,535 Kg	3,575 Kg		3,630 Kg		3,705 Kg		3,850 Kg



S.161DBOX1



SL.DBOX1



SL.DBOX112



SL.DBOX500



SL.DBOX501



S.360DBOX1



S.360DBOX112



SXL.DBOX1



SETS OF 1/2" METRIC 'DETECTION BOX' SOCKETS

		SL.DBOX4	SL.DBOX412	S.360DBOX4	S.360DBOX112	SXL.DBOX2	SXL.DBOX3
		SL.161	SL.161	S.360	S.360	SXL.161	SXL.171
		6	12	6	12	6	6
Socket		Standard	Standard	Standard	Standard	Standard	Standard
mm	8	•	•	•	•		
	9	•	•	•	•		
	10	•	•	•	•	•	•
	11	•	•	•	•	•	•
	12	•	•	•	•	•	•
	13	•	•	•	•	•	•
	14	•	•	•	•	•	•
	15	•	•	•	•	•	•
	16	•	•	•	•	•	•
	17	•	•	•	•	•	•
	18	•	•	•	•	•	•
	19	•	•	•	•	•	•
	21	•	•	•	•	•	•
	22	•	•	•	•	•	•
	23	•	•	•	•	•	•
24	•	•	•	•	•	•	
25							
26							
27	•	•	•	•	•	•	
28							
29							
30	•	•	•	•	•	•	
32	•	•	•	•	•	•	
S.210							
S.215					•		
S.210RC						•	
S.215RC						•	
S.210S	•	•	•	•	•		
S.240A							
S.120A	•	•	•	•			
S.232B						•	
		BV.S2NANO			BV.S3NANO		
		340 x 480 x 58 mm					
		3,435 Kg		3,565 Kg		3,705 Kg	3,835 Kg



SL.DBOX4



SL.DBOX412



S.360DBOX4



S.360DBOX412



SXL.DBOX2



SXL.DBOX3



FLUO

RFid



SETS OF 1/2" METRIC MBOX SOCKETS

15
PIEZAS



6 12 8 9 10 11 12 13 14 15 16 17 18 19
20 21 22 23 24 26 27 28 29 30 32 34

130 mm 250 mm

Part No.	Code	Image	Qty	Material	Code	Dimensions	Weight [kg]
S.151-1P6	S.151B		6	BP.MBOXM	PL.M03	329 x 219 x 59 mm	2.250
S.151-1P12	S.151B		12	BP.MBOXM	PL.M03	329 x 219 x 59 mm	2.250

19
PIEZAS



6 12 8 9 10 11 12 13 14 15 16 17 18 19
20 21 22 23 24 26 27 28 29 30 32 34

130 mm 250 mm

Part No.	Code	Image	Qty	Material	Code	Dimensions	Weight [kg]
S.151-2P6	S.151B		6	BP.MBOXM	PL.M02	329 x 219 x 59 mm	2.970
S.151-2P12	S.151B		12	BP.MBOXM	PL.M02	329 x 219 x 59 mm	2.970
S.161-2P6	S.161B		6	BP.MBOXM	PL.M02	329 x 219 x 59 mm	2.980
S.161-2P12	S.161B		12	BP.MBOXM	PL.M02	329 x 219 x 59 mm	2.980
SL.161-2P6	SL.161		6	BP.MBOXM	PL.M02	329 x 219 x 59 mm	3.020
SL.161-2P12	SL.161		12	BP.MBOXM	PL.M02	329 x 219 x 59 mm	3.020

23
PIEZAS



6 12 8 9 10 11 12 13 14 15 16 17 18 19
20 21 22 23 24 26 27 28 29 30 32 34

130 mm 250 mm

Part No.	Code	Image	Qty	Material	Code	Dimensions	Weight [kg]
S.161-3P6	S.161B		6	BP.MBOXM	PL.M01	329 x 219 x 59 mm	3.600
S.161-3P12	S.161B		12	BP.MBOXM	PL.M01	329 x 219 x 59 mm	3.600
SL.161-3P6	SL.161		6	BP.MBOXM	PL.M01	329 x 219 x 59 mm	3.640
SL.161-3P12	SL.161		12	BP.MBOXM	PL.M01	329 x 219 x 59 mm	3.640
SL.171-3P6	SL.171		6	BP.MBOXM	PL.M01	329 x 219 x 59 mm	3.705
SL.171-3P12	SL.171		12	BP.MBOXM	PL.M01	329 x 219 x 59 mm	3.705
S.360-3P6	S.360		6	BP.MBOXM	PL.M01	329 x 219 x 59 mm	3.770
S.360-3P12	S.360		12	BP.MBOXM	PL.M01	329 x 219 x 59 mm	3.770

SETS OF 1/2" METRIC MBOX SOCKETS

26
PIEZAS



6 12 8 9 10 11 12 13 14 15 16 17 18 19
20 21 22 23 24 26 27 28 29 30 32 34

130 mm 250 mm

REF	KEY	6 12	BP.MBOXL	PLL02	434 x 270 x 70 mm	ΔΔ [kg]
S.161-4P6	S.161B	6	BP.MBOXL	PLL02	434 x 270 x 70 mm	3.790
S.161-4P12	S.161B	12	BP.MBOXL	PLL02	434 x 270 x 70 mm	3.790
SL.161-4P6	SL.161	6	BP.MBOXL	PLL02	434 x 270 x 70 mm	3.830
SL.161-4P12	SL.161	12	BP.MBOXL	PLL02	434 x 270 x 70 mm	3.830
SL.171-4P6	SL.171	6	BP.MBOXL	PLL02	434 x 270 x 70 mm	3.895
SL.171-4P12	SL.161	12	BP.MBOXL	PLL02	434 x 270 x 70 mm	3.895
S.360-4P6	S.360	6	BP.MBOXL	PLL02	434 x 270 x 70 mm	3.960
S.360-4P12	S.360	12	BP.MBOXL	PLL02	434 x 270 x 70 mm	3.960
SXL.161-4P6	SXL.161	6	BP.MBOXL	PLL02	434 x 270 x 70 mm	5.100
SXL.161-4P12	SXL.161	12	BP.MBOXL	PLL02	434 x 270 x 70 mm	5.100

30
PIEZAS



6 12 8 9 10 11 12 13 14 15 16 17 18 19
20 21 22 23 24 26 27 28 29 30 32 34

130 mm 250 mm

REF	KEY	6 12	BP.MBOXL	PLL03	434 x 270 x 70 mm	ΔΔ [kg]
S.161-5P6	S.161B	6	BP.MBOXL	PLL03	434 x 270 x 70 mm	5.755
S.161-5P12	S.161B	12	BP.MBOXL	PLL03	434 x 270 x 70 mm	5.755
SL.161-5P6	SL.161	6	BP.MBOXL	PLL03	434 x 270 x 70 mm	5.795
SL.161-5P12	SL.161	12	BP.MBOXL	PLL03	434 x 270 x 70 mm	3.795



FLUO

Rfid



SETS OF 1/2" INCH MBOX SOCKETS

15
PIECES



6 12 3/8 7/16 1/2 9/16 19/32 5/8 21/32
11/16 3/4 25/32 13/16 7/8 15/16 31/32
1' 1' 1/16 1' 1/8 1' 3/16 1' 1/4

130 mm 250 mm

Icon	Key	6 12	BP.MBOXM	PL.M05	329 x 219 x 59 mm	ΔΔ [kg]
S.161-1P6U	S.161B	6	BP.MBOXM	PL.M05	329 x 219 x 59 mm	2.645
S.161-1P12U	S.161B	12	BP.MBOXM	PL.M05	329 x 219 x 59 mm	2.645
SL.161-1P6U	SL.161	6	BP.MBOXM	PL.M05	329 x 219 x 59 mm	2.685
SL.161-1P12U	SL.161	12	BP.MBOXM	PL.M05	329 x 219 x 59 mm	2.685

22
PIECES



6 12 3/8 7/16 1/2 9/16 19/32 5/8 21/32
11/16 3/4 25/32 13/16 7/8 15/16 31/32
1' 1' 1/16 1' 1/8 1' 3/16 1' 1/4

130 mm 250 mm

Icon	Key	6 12	BP.MBOXL	PL.L05	434 x 270 x 70 mm	ΔΔ [kg]
S.161-2P6U	S.161B	6	BP.MBOXL	PL.L05	434 x 270 x 70 mm	4.410
S.161-2P12U	S.161B	12	BP.MBOXL	PL.L05	434 x 270 x 70 mm	4.410
SL.161-2P6U	SL.161	6	BP.MBOXL	PL.L05	434 x 270 x 70 mm	4.450
SL.161-2P12U	SL.161	12	BP.MBOXL	PL.L05	434 x 270 x 70 mm	4.450

25
PIECES















6 12 3/8 7/16 1/2 9/16 19/32 5/8 21/32
11/16 3/4 25/32 13/16 7/8 15/16 31/32
1' 1' 1/16 1' 1/8 1' 3/16 1' 1/4

130 mm 250 mm

Icon	Key	6 12	BP.MBOXL	PL.L06	434 x 270 x 70 mm	ΔΔ [kg]
S.161-3P6U	S.161B	6	BP.MBOXL	PL.L06	434 x 270 x 70 mm	5.115
S.161-3P12U	S.161B	12	BP.MBOXL	PL.L06	434 x 270 x 70 mm	5.115
SL.161-3P6U	SL.161	6	BP.MBOXL	PL.L06	434 x 270 x 70 mm	5.155
SL.161-3P6U	SL.161	6	BP.MBOXL	PL.L06	434 x 270 x 70 mm	5.155

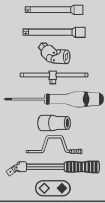
SETS OF 1/2" METRIC AND INCH MBOX SOCKETS



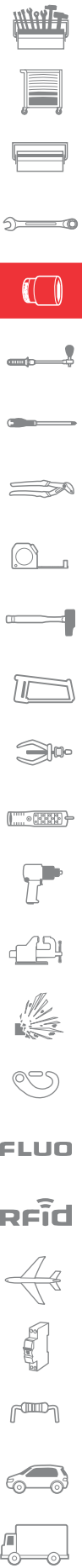











			S.447ADP	S.446ADP	S.851	S.850	S.450EP	S.450UP	
Socket	mm	inch	S.161B mm Standard	S.161B mm Standard	S.161B mm Standard	S.161B mm Standard	S.161B + S.156 mm Std + long	S.161B + S.156 Inch Std + long	
	8		•	•	•	•	•	•	
	9		•	•	•	•	•	•	
	10	3/8	•	•	•	•	•	•	
	11	7/16	•	•	•	•	•	•	
	12	1/2	•	•	•	•	•	•	
	13	9/16	•	•	•	•	•	•	
	14	19/32	•	•	•	•	•	•	
	15	5/8	•	•	•	•	•	•	
	16	21/32	•	•	•	•	•	•	
	17	11/16	•	•	•	•	•	•	
	18	3/4	•	•	•	•	•	•	
	19	25/32	•	•	•	•	•	•	
	20	13/16	•	•	•	•	•	•	
	21	7/8	•	•	•	•	•	•	
	22	15/16	•	•	•	•	•	•	
	23	31/32	•	•	•	•	•	•	
	24	1	•	•	•	•	•	•	
	26	1 1/16	•	•	•	•	•	•	
	27	1 1/8	•	•	•	•	•	•	
	28	1 1/4	•	•	•	•	•	•	
29									
30			•	•	•	•	•		
32			•	•	•	•	•		
	EP	1			•	•			
		2			•	•			
		3				•	•		
	EH	30 mm : 70 mm							
	5	5	•	•	•	•			
	6	6	•	•	•	•			
	7	7	•	•	•	•			
	8	8	•	•	•	•			
	10	10	•	•	•	•			
	ED	1			•	•			
		2			•	•			
		3				•	•		
		4					•	•	
	ES	5,5							
		6,5				•	•		
		8				•	•		
		10				•	•		
		12				•	•		
		14						•	•
16						•	•		
	EXR	10							
		15				•	•		
		20				•	•		
		25				•	•		
		27				•	•		
		30				•	•		
		40				•	•		
		45				•	•		
	S.210		•	•	•	•	•	•	
	S.215		•	•	•	•	•	•	
	S.240A		•	•	•	•	•	•	
	S.120A		•	•	•	•	•	•	
	S.236		•	•	•	•	•	•	
	S.237		•	•	•	•	•	•	
	S.110								
	S.141A								
S.234									
			PL.L07		PL.L08		PLT.11, PL.23A, PL.24A	PLT.11, PL.23A, PL.25A	
				BP.MBOXL 434 x 270 x 70 mm			BT.108 452 x 284 x 111 mm		
			5,075 Kg		4,540 Kg		14,750 Kg	13,350 Kg	



FLUO

RFid

SETS OF 1/2" METRIC MBOX SOCKETS

		 S.401B	 S.400B	 S.405AE	 S.404AE	 STM.J9A	AMEX.3A	
		 TORX®					TORX®	
Socket	mm	Standard	Standard	Long	Long	Hexagonal bit socket	TORX® bit socket	
	8	•	•					
	9	•	•					
	10	•	•					
	11	•	•					
	12	•	•	•	•			
	13	•	•	•	•			
	14	•	•	•	•			
	15	•	•	•	•			
	16	•	•	•	•			
	17	•	•	•	•			
	18	•	•	•	•			
	19	•	•	•	•			
	20							
	21	•	•	•	•			
	22	•	•	•	•			
	23	•	•	•	•			
24	•	•	•	•				
25								
26	•	•	•	•				
27	•	•	•	•				
28	•	•	•	•				
29	•	•	•	•				
30	•	•	•	•				
32	•	•	•	•				
	5					•		
	6					•		
	7					•		
	8					•		
	10					•		
	12					•		
	14					•		
	17					•		
19					•			
	T20						•	
	T25						•	
	T27						•	
	T30						•	
	T40						•	
	T45						•	
	T50						•	
	T55						•	
T60						•		
		PL.M04 BP.MBOXM 329 x 219 x 59 mm 2,900 Kg		PL.L09 BP.MBOXL 434 x 270 x 70 mm 4,620 Kg		PL.S02 BP.MBOXS 210 x 139 x 59 mm 1,150 Kg 0,970 Kg		

S.401B
S.400B



S.405AE
S.404AE



STM.J9A



AMEX.3A



SETS OF 1/4" AND 1/2" METRIC MBOX SOCKETS

 Socket mm		RSX.427AP	RS.161-1	RS.360-1	RS.161-2
		R.161B S.161B Torx Torx Standard	R.161B S.161B 6 1/4" 1/2" Standard	R.360 S.161B 6 1/4" 1/2" Standard	R.161B S.161B 6 1/4" 1/2" Standard
5,5					
6					
7					
8					
9					
10					
11					
12					
13					
14					
15					
16					
17					
18					
19					
21					
22					
24					
27					
30					
32					
E4					
E5					
E6					
E7					
E8					
E10					
S12					
E14					
E16					
E18					
E20					
EP					
2					
3					
EH					
3					
4					
5					
6					
7					
ED					
1					
2					
3					
ES					
4,5					
6,5					
8					
EX					
T8					
T10	TT10				
T15	TT15				
T20	TT20				
T25	TT25				
T27	TT27				
T30	TT30				
T40	TT40				
R.209					
R.210					
R.240A					
R.235					
R.236A					
AM.H					
S.210					
S.240A					
PL.M24					
329 x 219 x 59 mm					
2,100 Kg					
PL.M25					
BP.MBOXM					
329 x 215 x 59 mm					
2,890 Kg					
2,950 Kg					
PL.L16					
BP.MBOXL					
434 x 270 x 70 mm					
4,020 Kg					

RSX.427AP



RS.161-1



RS.360-1



RS.161-2



FLUO

RFid

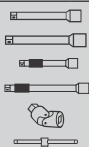

1/2" MODULES IN THERMOFORMED TRAYS METRIC

		MOD.S161-36	MOD.SL161-36	MOD.S161-46	MOD.SL161-46
		S.161B	SL.161	S.161B	SL.161
		Standard	Standard	Standard	Standard
	mm				
	8	•	•	•	•
	9	•	•	•	•
	10	•	•	•	•
	11	•	•	•	•
	12	•	•	•	•
	13	•	•	•	•
	14	•	•	•	•
	15	•	•	•	•
	16	•	•	•	•
	17	•	•	•	•
	18	•	•	•	•
	19	•	•	•	•
	21	•	•	•	•
	22	•	•	•	•
		S.210	•	•	•
S.215		•	•	•	•
S.210RC					
S.215RC					
S.240A		•	•	•	•
S.120A				•	•
		PL.M01 309 x 188 mm		PL.L02 410 x 188 mm	
		2,985 Kg	3,025 Kg	3,680 Kg	3,720 Kg

MOD.S161-36



MOD.SL161-36











MOD.S161-46



MOD.SL161-46



1/2" MODULES IN THERMOFORMED TRAYS INCH

		MOD.S161-112U	MOD.SL161-112U	MOD.S161-212U	MOD.SL161-212U
Socket	 inch	S.161B	SL.161	S.161B	SL.161
	 Standard	Standard	Standard	Standard	Standard
	3/8	•	•	•	•
	7/16	•	•	•	•
	1/2	•	•	•	•
	9/16	•	•	•	•
	19/32	•	•	•	•
	5/8	•	•	•	•
	21/32	•	•	•	•
	11/16	•	•	•	•
	3/4	•	•	•	•
	13/16	•	•	•	•
	7/8	•	•	•	•
	15/16				
	1				
	1 1/16				
1 1/8					
1 3/16					
1 1/4					
	S.210	•	•	•	•
	S.215	•	•	•	•
	S.210RC				
	S.215RC				
	S.240A	•	•	•	•
	S.120A			•	•
		PL.M05 309 x 188 mm		PL.L05 410 x 188 mm	
		2,030 Kg	2,070 Kg	3,300 Kg	3,340 Kg

MOD.S161-112U



MOD.SL161-112U



MOD.S161-212U



MOD.SL161-212U









FLUO

RFid



1/2" MODULES IN THERMOFORMED TRAYS HEXAGONAL, TORX, XZN

Socket	mm	MOD.HLB		MOD.TX1A		MOD.CH		MOD.SHPA
		3/8"	1/2"	3/8"	1/2"	3/8"	1/2"	1/2"
		Long sockets		Sockets + wrenches		Sockets + long sockets		Sockets + bit sockets
	7	•						
	8	•						
	9	•						
	10	•						
	11	•						
	12		•					
	13							
	14							
	15							
	16							
	17							
18								
19								
 Torx sockets 3/8" JTX	E8			•		•		
	E10			•		•		
	E12			•				
	E14			•				
	E16			•				
 Torx sockets 1/2" STX	E12						•	
	E14						•	
	E16						•	
	E18						•	
	E20				•		•	
Torx wrenches 59	E6 x E8			•				
	E10 x E12			•				
	E14 x E16			•				
	E18 x E20			•				
 Resistorx bits EXR.1	TT10			•			•	
	TT15			•				
	TT20			•				
	TT25			•				
	TT27			•				
	TT30			•				•
TT40			•				•	
 Torx bits EXR.2	T40			•			•	
	T45			•			•	
	T50			•			•	
	T55			•			•	
					•			•
Hexagonal bit sockets SHP.LA	5					•	•	
	6					•	•	
	7					•	•	
	8					•	•	
	10					•	•	
Splines sockets D.34BL	7					•	•	
	9					•	•	
	10					•	•	
	12					•	•	
	14					•	•	
XZN sockets SV.LB	M6					•	•	
	M8					•	•	
	M10					•	•	
	M12					•	•	
	M14					•	•	
	M16					•	•	
	M18					•	•	
Bit sockets SX.LA	T40						•	
	T45						•	
	T55					•	•	
	T70					•	•	
	R.235			•				
	J.235			•				
	S.236			•				
		PL.M06		PL.M08		PL.663		PL.336A
		309 x 188 x 55 mm 1,445 Kg		1,100 Kg		410 x 188 x 55 mm 2,750 Kg		2,150 Kg

MOD.HLB



MOD.TX1A









MOD.CH



MOD.SHPA



1/2" MODULES IN THERMOFORMED TRAYS METRIC

		MODM.S161-36	MODM.SL161-36	MODM.SL171-36	MODM.S1A	MODM.SL1	
		S.161B	SL.161	SL.171	S.161B	SL.161	
		6 mm Standard	6 mm Standard	6 mm Standard	6 mm Standard	6 mm Standard	
	8	•	•	•	•	•	
	9	•	•	•	•	•	
	10	•	•	•	•	•	
	11	•	•	•	•	•	
	12	•	•	•	•	•	
	13	•	•	•	•	•	
	14	•	•	•	•	•	
	15	•	•	•	•	•	
	16	•	•	•	•	•	
	17	•	•	•	•	•	
	18	•	•	•	•	•	
	19	•	•	•	•	•	
	21	•	•	•	•	•	
	22	•	•	•	•	•	
	23	•	•	•	•	•	
	24	•	•	•	•	•	
     	S.210	•	•	•	•	•	
	S.215	•	•	•	•	•	
	S.210RC			•			
	S.215RC			•			
	S.240A	•	•	•	•	•	
	S.120A				•	•	
			PM.MODS161-3			PM.MODS1A	
			410 x 188 x 55 mm				
		2,840 Kg	2,880 Kg	3,030 Kg	3,150 Kg	3,190 Kg	

MOD.S161-36



MOD.SL161-36



MOD.SL1









FLUO

Rfid



SOCKETS 1/2"

1/2" MODULES IN FOAM TRAYS INCH

 		MODM.S161-212U	MODM.SL161-212U
Socket	inch	S.161B Standard	SL.161 Standard
	inch	inch	inch
	3/8	•	•
	7/16	•	•
	1/2	•	•
	9/16	•	•
	19/32	•	•
	5/8	•	•
	21/32	•	•
	11/16	•	•
	3/4	•	•
	13/16	•	•
	7/8	•	•
	15/16	•	•
	1	•	•
	1'1/16	•	•
	1'1/8	•	•
	1'3/16	•	•
	1'1/4	•	•
	J.210	•	•
	J.215	•	•
	J.210RC		
	J.215RC		
	J.240A	•	•
	J.120A	•	•
PM.MODS161-2U			
410 x 188 x 55 mm			
		1,450 Kg	1,490 Kg

MODM.S161-212U





MODM.SL161-212U





Sets of 1/2" sockets in metallic rack



	A ["]	A [mm]	 Torx [No]	Contents	Qtés	ΔΔ [kg]
S.40E		S. 8 - 9 - 10 - 11 - 12 - 13 - 14 - 15 - 16	12	CKS.95	9	0,560
S.41E		S. 17 - 18 - 19 - 20 - 21 - 22 - 23 - 24	12	CKS.95	8	0,790
S.40U	S. 3/8" - 7/16" - 1/2" - 9/16" - 19/32" - 5/8"		12	CKS.97	21	0,475
S.41U	S. 11/16" - 3/4" - 13/16" - 7/8" - 15/16" - 1"		12	CKS.95	22	0,645
STX.40			HCl STX. E12 - E14 - E16 - E18 - E20	CKS.90	5	0,385



1/2" MODULES IN FOAM TRAYS, METRIC, HEXAGONAL, TORX, XZN

Socket	mm	MODM.HLA		MODM.CHA		MODM.SHP
		3/8" Long sockets	1/2" Long sockets	3/8" Sockets + long sockets	1/2" Sockets + long sockets	1/2" Sockets + bit sockets
	7	•				
	8	•				
	9	•				
	10	•				
	11	•				
	12		•			
	13					
	14					
	15					
	16					
17						
18						
19						
Douilles Torx 1/4" RTX	E8			•		
	E8			•		
	E10			•		
	E12					
	E14					
	E16					
	S12				•	
	E14				•	
	E16				•	
	E18				•	
	E20				•	
Hexagonal bit sockets STM	5					•
	6					•
	7					•
	8					•
	10					•
	12					•
	14					•
17					•	
19					•	
Hexagonal bit sockets SHP.LA	5					•
	6			•		•
	7			•		•
	8			•		•
	10			•		•
12			•		•	
Bit sockets XZN SV.LB	M6			•		
	M8			•		
	M10			•		
	M12			•		
	M14			•		
	M16			•		
	M18			•		
Bit sockets SX.LA	T40			•		
	T45			•		
	T55			•		
	T70			•		
		PM.MODHLA		PM.MODCHAM17		PM.SHP
		410 x 188 x 55 mm				
		1,385 Kg		2,580 Kg		1,480 Kg

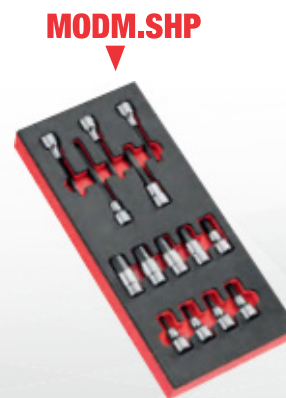

FLUO

Rfid

MAINTENANCE OF 1/2" RATCHETS

Kit : 151B					
Kit : 161B					

	151 style 151B style	161 style 161B style
1/2" 12.7 mm	 S.151B-KIT : S.151, S.151B, S.154	 S.161B-KIT : S.161, S.161B, S.143A, S.153A, S.155A, S.157A, S.158A

RATCHETS 1/2"

1/2" fast action twist handle ratchet

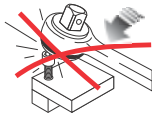
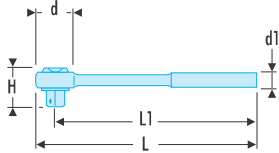

NF ISO 3315, ISO 3315, DIN 3122, ASME B107.10

1/2" fast action twist handle ratchet

- Rotating handle jack: work twice as fast in confined spaces.
- 6° increments for final tightening.
- Socket safety locking = no sockets lost in your machines.
- Palm control system - allows the operator to press down on the head avoiding risk of accidental reverse.



	d [mm]	d1 [mm]	H [mm]	L [mm]	L1 [mm]	ΔΔ [g]
S.360	45	37	41	251	230	570

1/2" maintenance free pear head locking ratchet

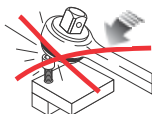
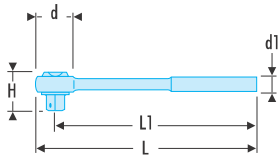

NF ISO 3315, ISO 3315, DIN 3122, ASME B107.10

- Socket locking and quick release system.
- Dust proof, maintenance free mechanism.
- 72 teeth mechanism for 5° increments.
- Drive direction switch allows easy reversal even with gloved or greasy hands.
- Palm control system - allows the operator to press down on the head avoiding risk of accidental reverse
- Ultra-compact head.
- Hook for hanging when working at height.
- Ergonomic comfort grip handle design resistant to workshop chemicals and solvents.
- Finish: bright chrome.
- Présentation : chromée brillante.



	d [mm]	d1 [mm]	H [mm]	L [mm]	L [mm]	ΔΔ [g]
SL.171	37	32	37	262	245	450

1/2" maintenance free pear head ratchet

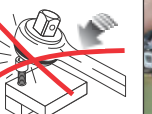
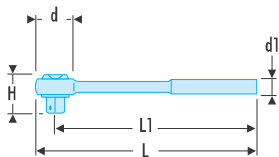

NF ISO 3315, ISO 3315, DIN 3122, ASME B107.10

- Dust proof, maintenance free mechanism.
- 72 teeth mechanism for 5° increments.
- Drive direction switch allows easy reversal even with gloved or greasy hands.
- Palm control system - allows the operator to press down on the head avoiding risk of accidental reverse
- Ultra-compact head.
- Hook for hanging when working at height.
- Ergonomic comfort grip handle design resistant to workshop chemicals and solvents.
- Présentation : chromée brillante.



	d [mm]	d1 [mm]	H [mm]	L [mm]	L1 [mm]	ΔΔ [g]
SL.161	37	32	37	262	245	445

High performance sealed 1/2" ratchet

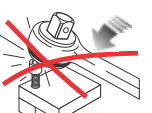
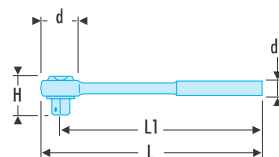

NF ISO 3315, ISO 3315, DIN 3122, ASME B107.10

- Very long durability regardless of working conditions. Mechanism sealed to industrial dust.
- 72 tooth mechanism for 5° increments.
- Reversing by rotating cap.
- Ultra-compact head.
- Bi-material elastomer grip: high resistance to abrasion and the most severe workshop solvents: SP95, SP98, diesel fuel, acetone, brake fluid, Skydrol, Jet Oil, kerosene.
- Hole in the handle for strapping when working in high places.
- Easy maintenance: spare parts kit S.161B-KIT.
- Finish: chromed.



	d [mm]	d1 [mm]	H [mm]	L [mm]	L1 [mm]	ΔΔ [g]
S.161B	38,5	18,1 / 33,1	38,2	260	244	410

Original 1/2" ratchet

- 72 tooth mechanism for 5° increments.
- Reversing by rotating cap.
- Ultra-compact head.
- Single material elastomer grip: high resistance to abrasion and the most severe workshop solvents: SP95, SP98, diesel fuel, acetone, brake fluid, Skydrol, Jet Oil, kerosene.
- Hole in the handle for strapping when working in high places.
- Easy maintenance: spare parts kit S.151B-KIT.
- Finish: mat chrome.



	d [mm]	d1 [mm]	H [mm]	L [mm]	L1 [mm]	ΔΔ [g]
S.151B	38,5	31,3 / 33,7	38,2	260	244	400

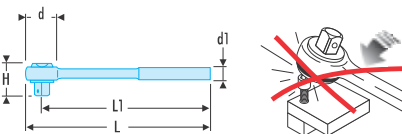

Long-reach 1/2" ratchet

- Long-reach 1/2" ratchet
- 72 teeth mechanism for 5° increments.
- Reversing by rotating cap.
- Length: 400 mm (applies more torque and reduces effort).



	d [mm]	d1 [mm]	H [mm]	L [mm]	L1 [mm]	ΔΔ [g]
S.154	40	30	40	404	38	780

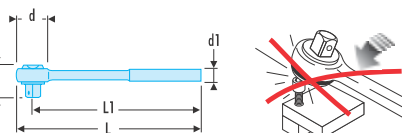

1/2" extendable ratchet

- 1 ratchet instead of 2.
- Short setting: standard use, easy storage.
- Long setting: more torque, less effort.
- Easy to use & strong extension mechanism.
- Watertight: no maintenance.
- High accuracy: 72 teeth, 5° increments.
- Présentation : chromée satinée.



	d [mm]	d1 [mm]	H [mm]	L [mm]	L1 [mm]	ΔΔ [g]
SXL161	37	38	37	264	397	720

Flexible head 1/2" locking extendable ratchet

- 2 in 1 extendable ratchet. Standard use and easy storage in closed position. More torque, less effort and maximum accessibility when used lying.
- Total length 304 to 437 mm. 8 settings positions with secured extension mechanism.
- 180° hinged head and socket locking: allows to keep position with an already engaged socket.
- Extended lifetime whatever the working conditions. No service needed. Dust proof.
- 72 teeth mechanism for 5° increments.
- Socket locking system : prevents tools loss in machines.
- Ring reversing : easy to use even with a gloved hand. Allows viewing rotating direction
- "Hand palm" system allows pressing the head while tightening avoiding accidental reversal of rotating direction.
- Ultra compact head.
- Bi material elastomer handle : high resistance to abrasion and solvents in the most severe conditions: fuel, diesel, gasoline, acetone, brake fluid, Skydrol, Jet Oil, kerosene.
- FME compatible hanging system.
- Chrome Satin finish.



	d [mm]	d1 [mm]	H [mm]	L [mm]	L1 [mm]	ΔΔ [g]
SXL171	37	38	37	304	437	830

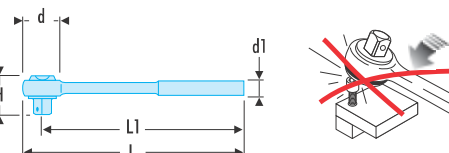

FLUO

Rfid



ACCESSORIES 1/2"

1/2" offset ratchet

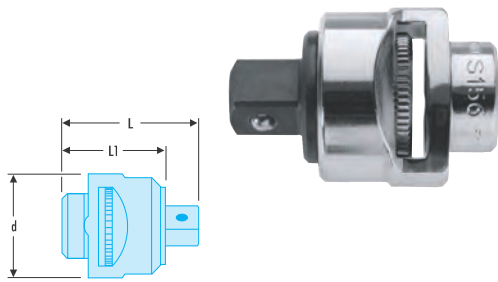

- Female square drive bit 1/2".
- Male square drive bit 1/2".
- Increment: 5°.
- Finish: bright chrome with phosphate-hardened square drive.



🔧	d [mm]	L [mm]	L1 [mm]	ΔΔ [g]
S.156	39	59	41	230

1/2" drive sliding tee

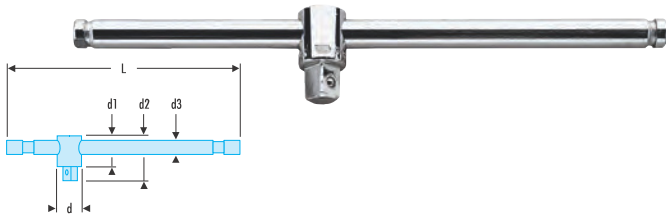

- NF ISO 3315, ISO 3315, DIN 3122, ASME B107.10**
- Friction-head allows bar to form a T or L-handle.
 - Finish: bright chrome.



🔧	d [mm]	d1 [mm]	d2 [mm]	d3 [mm]	L [mm]	ΔΔ [g]
S.120A	24	29	45	14	275	275

1/2" drive hinged handle

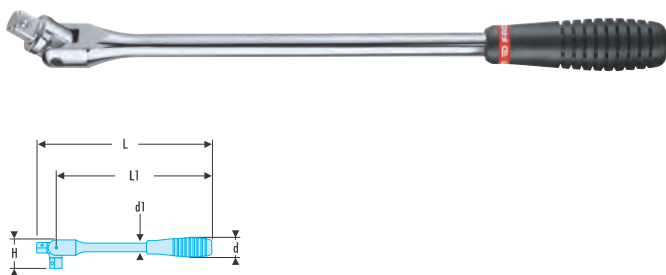

- NF ISO 3315, ISO 3315, DIN 3122, ASME B107.10**
- 180° hinged and secured head to maintain the position even with a socket engaged.
 - Bi-material elastomer grip: high resistance to abrasion and the most severe workshop solvents: SP95, SP98, diesel fuel, acetone, brake fluid, Skydrol, Jet Oil, kerosene.



🔧	d [mm]	d1 [mm]	H [mm]	L [mm]	L1 [mm]	ΔΔ [g]
S.141A	31	14	41	381	349,5	595

1/2" drive metal-grip hinged handle

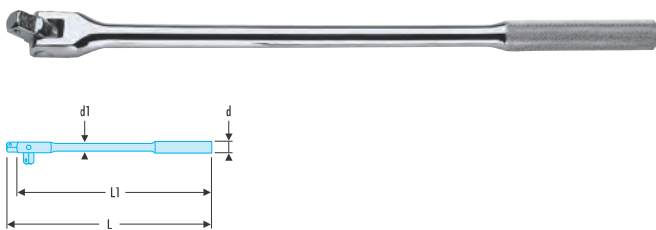

- NF ISO 3315, ISO 3315, DIN 3122, ASME B107.10**
- 180° hinged and secured head to maintain the position even with a socket engaged.
 - Metal handle with knurled handle.



🔧	d [mm]	d1 [mm]	L [mm]	L1 [mm]	ΔΔ [g]
S.145	20	15	410	392	740

Hinged extendable handle 1/2"



- 1 handle instead of 2.
- Short setting: standard use, easy storage.
- Long setting: more torque, less effort.
- Easy to use & strong extension mechanism.



🔧	H [mm]	L [mm]	L1 [mm]	ΔΔ [g]
SXL.180	54	246	280 / 413	660

■ **1/2" drive speed brace**

NF ISO 3315, ISO 3315, DIN 3122, ASME B107.10

- Significant time-savings whenever space allows.
- PVC rotating handle.
- Finish: bright chrome.

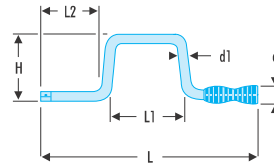

Icon	d [mm]	d1 [mm]	H [mm]	L [mm]	L1 [mm]	L2 [mm]	ΔΔ [g]
S.110	29	12	115	402	130	130	510

■ **1/2" drive tee with universal joint**

- Universal joint for high torques.
- Finish: bright chrome.

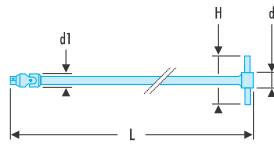

Icon	d [mm]	d1 [mm]	H [mm]	L [mm]	ΔΔ [g]
S.229A	18	24	180	495	550

■ **1/2" extra-long drive tee with universal joint**

- Extended reach of tee-handle is ideal for particularly deep recesses.
- Finish: bright chrome.

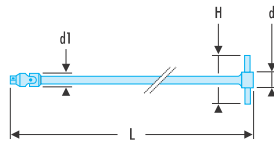

Icon	d [mm]	d1 [mm]	H [mm]	L [mm]	ΔΔ [g]
S.228	24	25	240	700	1200

■ **S - 1/2" drive extensions**

NF ISO 3316, ISO 3316, DIN 3123, ASME B107.10

- Finish: bright chrome.

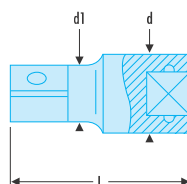

Icon	d [mm]	d1 [mm]	L [mm]	Square ["]	ΔΔ [g]
S.206	23	16,5	52,5	1/2	90
S.208	23	16,5	75	1/2	130
S.210	23	16,5	130	1/2	225
S.215	23	16,5	250	1/2	420
S.217	23	16,5	500	1/2	840

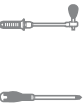
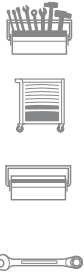

FLUO

Rfid



ACCESSORIES 1/2"

WOBBLE EXTENSION

Hard to access with a socket or universal joint?
Use a wobble extension!

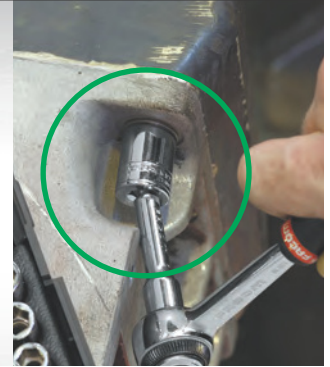
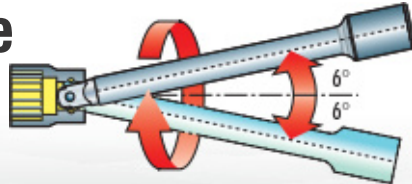

S.S - 1/2" wobble drive extensions

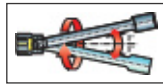
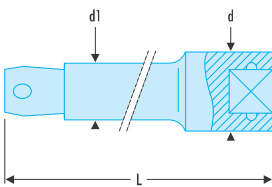

- Square drive rounded profile gives 8° working angle.
- Useful where access is limited.
- Finish: bright chrome.

Part No.	d [mm]	d1 [mm]	L [mm]	Square ["]	ΔΔ [g]
S.208S	23	16,5	75	1/2	130
S.210S	23	16,5	130	1/2	225
S.215S	23	16,5	250	1/2	420



S.RC - 1/2" drive locking extensions

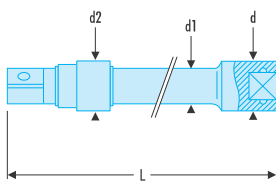

NF ISO 3316, ISO 3316, DIN 3123, ASME B107.10

- Total safety as lock system prevents socket loss.
- Safety and instant release, by retracting knurled ring, for total user confidence.
- Positive locking for use with sockets with internal ball notch.
- Finish: bright chrome with phosphate-hardened ring.

Part No.	d [mm]	d1 [mm]	d2 [mm]	L [mm]	Square ["]	ΔΔ [g]
S.210RC	23	16,5	23	130	1/2	250
S.215RC	23	16,5	23	250	1/2	450
S.217RC	23	16,5	23	500	1/2	860



1/2" universal joint

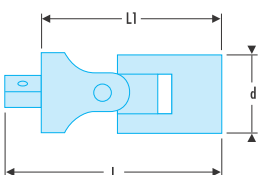

NF ISO 3316, ISO 3316, DIN 3123, ASME B107.10

- Spring-stiffened joint.
- Stays in position when reaching for fasteners.
- Significant time savings.
- Finish: bright chrome.

Part No.	d [mm]	L [mm]	L1 [mm]	ΔΔ [g]
S.240A	25	68,2	52,2	150



1/2" to 3/8" coupler

NF ISO 3316, ISO 3316, DIN 3123, ASME B107.10

- Double 3/8" coupler
- Permet l'utilisation de douilles et accessoires 3/8".
- Max torque: 212 N.m.
- Finish: bright chrome.



Part No.	d [mm]	L [mm]	L1 [mm]	ΔΔ [g]
S.230	23	33,5	23	55

1/2" to CDX® coupler

NF ISO 3316, ISO 3316, DIN 3123, ASME B107.10

- 1/2" female to CDX® male square drive.
- Double "CDX®" coupler.
- Finish: bright chrome.



Part No.	d [mm]	L [mm]	L1 [mm]	ΔΔ [g]
S.231	22	37	12	65

1/2" to 3/4" coupler

NF ISO 3316, ISO 3316, DIN 3123, ASME B107.10

- 1/2" female to 3/4" male square drive with plunger.
- For adapting sockets and accessories 3/4".
- Male square drive with plunger for positive locking of sockets and accessories.
- Finish: satin chrome.

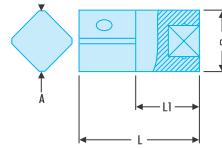

Part No.	d [mm]	L [mm]	L1 [mm]	ΔΔ [g]
S.232B	25	49	26	135

Set of 3 couplers

- Allows use of square drivers smaller than socket drive sizes:
 - 1/4" square drive + D.169RJ --> 3/8" socket (ø 1/4" : 28,7 - R 1/4" : 13 mm).
 - 3/8" square drive + D.169JS --> 1/2" socket (ø 3/8" : 37,8 - R 3/8" : 16 mm).
 - 1/2" square drive --> 3/4" socket (ø 1/4" : 43,9 - R 1/8" : 22).
- Compactness means that fewer tools are needed for in situ maintenance operations.
- Magnetic retainer and locking system (JS and SK).
- Knurl allows hand tightening where access is difficult.



Part No.	ΔΔ [g]
D.169	100

1/2" drive offset adaptor

- 1/2" female to 1/2" male square drive.
- Offset centrelines for enhanced accessibility.
- Finish: bright chrome.
- S.236: for 5/16 bits.
- S.237: for 1/2 bits.

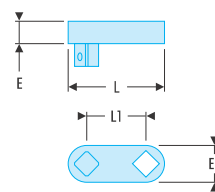

Part No.	E [mm]	E1 [mm]	L [mm]	L1 [mm]	ΔΔ [g]
S.234	15	25	65	40	165

S - 1/2" drive spring-clip bit holders

NF ISO 2725-1, NF ISO 1173, ISO 2725-1, ISO 1173, DIN 3124

- S.236: for 5/16 bits.
- S.237: for 1/2 bits.
- Finish: bright chrome.

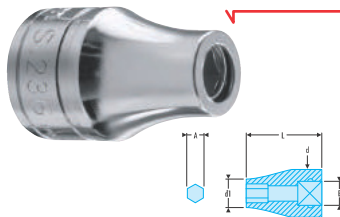

Part No.	A ["]	d [mm]	d1 [mm]	L [mm]	Square ["]	ΔΔ [g]
S.236	5/16	23,0	14	36	1/2	54
S.237	1/2	23	20,5	44	1/2	70

1/2" drive lock-ring bit holder

NF ISO 2725-1, NF ISO 1173, ISO 2725-1, ISO 1173, DIN 3124

- Bit lock.
- Square drive has side-hole for ball or plunger lock.



Part No.	A ["]	L [mm]	Square ["]	ΔΔ [g]
ERS	1/4	50	1/2	90

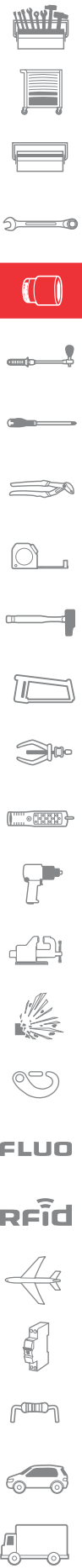

SOCKETS 1/2"

■ S.H - 1/2" metric 6-point sockets

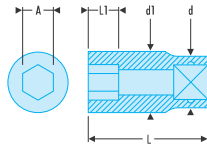

NF ISO 2725-1, NF ISO 1711-1, ISO 2725-1, ISO 1711-1, DIN 3124, ASME B107.5
 • OGV® profile: more powerful tightening, preserves fasteners.
 • Finish: bright chrome.

⊞	A [mm]	d [mm]	d1 [mm]	L [mm]	L1 [mm]	6 [mm]	ΔΔ [g]
S.8H	8	22,8	13,1	36	6,5	6	45
S.9H	9	22,8	13,8	36	6,5	6	50
S.10H	10	22,8	15,3	36	7,8	6	50
S.11H	11	22,8	16,5	36	9,0	6	50
S.12H	12	22,8	17,8	36	9,5	6	50
S.13H	13	22,8	18,9	36	10,4	6	50
S.14H	14	22,8	20,2	36	10,5	6	55
S.15H	15	22,8	21,4	36	12,0	6	55
S.16H	16	21,6	22,6	36	12,0	6	55
S.17H	17	23,1	24,1	36	13,0	6	65
S.18H	18	23,4	25,5	36	13,0	6	70
S.19H	19	24,6	26,6	36	14,0	6	75
S.20H	20	25,4	27,4	36	14,0	6	80
S.21H	21	25,1	29,1	38	16,0	6	85
S.22H	22	26,4	30,4	38	16,5	6	95
S.23H	23	27,6	31,6	38	16,5	6	105
S.24H	24	28,7	32,7	38	16,5	6	115
S.25H	25	27,7	34,1	38	16,5	6	125
S.26H	26	29,0	35,4	38	16,5	6	135
S.27H	27	29,2	36,6	44	19,0	6	160
S.28H	28	30,5	37,9	44	20,0	6	175
S.29H	29	31,3	38,7	44	20,0	6	190
S.30H	30	33,0	40,4	44	20,0	6	200
S.31H	31	34,2	41,6	44	20,0	6	205
S.32H	32	35,1	42,6	44	20,0	6	210
S.34H	34	37,5	44,9	44	20,0	6	240

■ S.H - 1/2" inch 6-point sockets

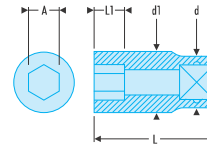

ASME B107.1
 • OGV® profile: more powerful tightening, preserves fasteners.
 • Finish: bright chrome.

⊞	A ["]	d [mm]	d1 [mm]	L [mm]	L1 [mm]	6 [mm]	ΔΔ [g]
S.3/8H	3/8	22,8	14,7	36	7,8	6	50
S.7/16H	7/16	22,8	16,5	36	9,0	6	50
S.1/2H	1/2	22,8	18,9	36	10,4	6	50
S.9/16H	9/16	22,8	20,2	36	10,5	6	50
S.19/32H	19/32	22,8	21,4	36	12,0	6	55
S.5/8H	5/8	21,6	22,6	36	12,0	6	60
S.21/32H	21/32	23,1	24,1	36	13,0	6	60
S.11/16H	11/16	22,6	24,6	36	13,0	6	65
S.3/4H	3/4	25,0	27,0	36	14,0	6	75
S.25/32H	25/32	25,9	27,9	36	14,0	6	80
S.13/16H	13/16	24,6	28,6	38	16,0	6	80
S.7/8H	7/8	26,4	30,4	38	16,5	6	90
S.15/16H	15/16	28,7	32,7	38	16,5	6	115
S.31/32H	31/32	27,7	34,1	38	16,5	6	115
S.1PH	1	28,3	34,7	38	16,5	6	120
S.1P1/16H	1 1/16	29,2	36,6	44	19,0	6	150
S.1P1/8H	1 1/8	31,3	38,7	44	20,0	6	170
S.1P3/16H	1 3/16	33,0	40,4	44	20,0	6	180
S.1P1/4H	1 1/4	35,1	42,5	44	20,0	6	205

■ S - 1/2" inch 12-point sockets

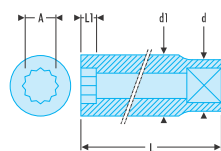

ASME B107.1
 • OGV® profile: more powerful tightening, preserves fasteners.
 • Available as rack set Ref S.40U (3/8" --> 21/32") and Ref S.41U (11/16" --> 1").
 • Finish: bright chrome.

⊞	A ["]	d [mm]	d1 [mm]	L [mm]	L1 [mm]	12 [mm]	ΔΔ [g]
S.3/8	3/8	22,8	14,7	36	7,8	12	50
S.7/16	7/16	22,8	16,5	36	9,0	12	50
S.1/2	1/2	22,8	18,9	36	10,4	12	50
S.9/16	9/16	22,8	20,2	36	10,5	12	50
S.19/32	19/32	22,8	21,4	36	12,0	12	55
S.5/8	5/8	21,6	22,6	36	12,0	12	60
S.21/32	21/32	23,1	24,1	36	13,0	12	60
S.11/16	11/16	22,6	24,6	36	13,0	12	65
S.3/4	3/4	25,0	27,0	36	14,0	12	75
S.25/32	25/32	25,9	27,9	36	14,0	12	80
S.13/16	13/16	24,6	28,6	38	16,0	12	80
S.7/8	7/8	26,4	30,4	38	16,5	12	90
S.15/16	15/16	28,7	32,7	38	16,5	12	115
S.31/32	31/32	27,7	34,1	38	16,5	12	115
S.1'	1	28,3	34,7	38	16,5	12	120
S.1'1/16	1 1/16	29,2	36,6	44	19,0	12	150
S.1'1/8	1 1/8	31,3	38,7	44	20,0	12	170
S.1'3/16	1 3/16	33,0	40,4	44	20,0	12	180
S.1'1/4	1 1/4	35,1	42,5	44	20,0	12	205

■ S - 1/2" metric 12-point sockets

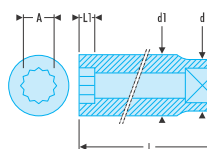

NF ISO 2725-1, NF ISO 1711-1, ISO 2725-1, ISO 1711-1, DIN 3124, ASME B107.5
 • OGV® profile: more powerful tightening, preserves fasteners.
 • Finish: bright chrome.
 • Supplied on metal rack. Ref S.40E (8 --> 16 mm) and Ref S.41E (17 --> 24 mm).

⊞	A [mm]	d [mm]	d1 [mm]	L [mm]	L1 [mm]	12 [mm]	ΔΔ [g]
S.8	8	22,8	13,1	36	6,5	12	45
S.9	9	22,8	13,8	36	6,5	12	50
S.10	10	22,8	15,3	36	7,8	12	50
S.11	11	22,8	16,5	36	9,0	12	50
S.12	12	22,8	17,8	36	9,5	12	50
S.13	13	22,8	18,9	36	10,4	12	50
S.14	14	22,8	20,2	36	10,5	12	55
S.15	15	22,8	21,4	36	12,0	12	55
S.16	16	21,6	22,6	36	12,0	12	55
S.17	17	23,1	24,1	36	13,0	12	65
S.18	18	23,4	25,5	36	13,0	12	70
S.19	19	24,6	26,6	36	14,0	12	75
S.20	20	25,4	27,4	36	14,0	12	80
S.21	21	25,1	29,1	38	16,0	12	85
S.22	22	26,4	30,4	38	16,5	12	95
S.23	23	27,6	31,6	38	16,5	12	105
S.24	24	28,7	32,7	38	16,5	12	115
S.25	25	27,7	34,1	38	16,5	12	125
S.26	26	29,0	35,4	38	16,5	12	135
S.27	27	29,2	36,6	44	19,0	12	160
S.28	28	30,5	37,9	44	20,0	12	175
S.29	29	31,3	38,7	44	20,0	12	190
S.30	30	33,0	40,4	44	20,0	12	200
S.31	31	34,2	41,6	44	20,0	12	205
S.32	32	35,1	42,5	44	20,0	12	210
S.34	34	37,5	44,9	44	20,0	12	240

■ S.HLA - 1/2" long-reach metric 6-point sockets

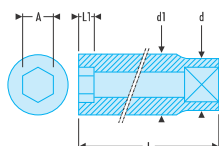

NF ISO 2725-1, NF ISO 1711-1, ISO 2725-1, ISO 1711-1, DIN 3124, ASME B107.5

- OGV® profile: more powerful tightening, preserves fasteners.
- Long-reach sockets for long recess or thread access.
- Finish: bright chrome.

➤	A [mm]	d [mm]	d1 [mm]	L [mm]	L1 [mm]	6 [mm]	ΔΔ [g]
S.12HLA	12	21,8	17,8	77	12	6	105
S.13HLA	13	21,8	19,0	77	12	6	115
S.14HLA	14	21,8	20,3	77	15	6	120
S.15HLA	15	21,8	21,5	77	15	6	125
S.16HLA	16	22,0	22,8	77	15	6	130
S.17HLA	17	23,0	24,0	77	15	6	140
S.18HLA	18	24,0	25,0	77	18	6	160
S.19HLA	19	25,0	26,5	77	18	6	160
S.21HLA	21	27,0	29,0	77	18	6	200
S.22HLA	22	28,0	30,0	77	21	6	215
S.23HLA	23	29,0	31,5	77	21	6	235
S.24HLA	24	30,0	32,8	77	24	6	255
S.26HLA	26	32,0	35,0	77	24	6	280
S.27HLA	27	33,0	36,5	77	27	6	310
S.28HLA	28	34,0	37,8	77	27	6	330
S.29HLA	29	35,0	39,0	77	27	6	355
S.30HLA	30	36,0	40,0	77	30	6	355
S.32HLA	32	38,0	42,8	77	33	6	410

■ S.LA - 1/2" long-reach metric 12-point sockets

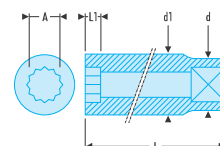

NF ISO 2725-1, NF ISO 1711-1, ISO 2725-1, ISO 1711-1, DIN 3124, ASME B107.5

- OGV® profile: more powerful tightening, preserves fasteners.
- Long-reach sockets for long recess or thread access.
- Finish: bright chrome.

➤	A [mm]	d [mm]	d1 [mm]	L [mm]	L1 [mm]	12 [mm]	ΔΔ [g]
S.12LA	12	21,8	17,8	77	12	12	105
S.13LA	13	21,8	19,0	77	12	12	115
S.14LA	14	21,8	20,3	77	15	12	120
S.15LA	15	21,8	21,5	77	15	12	125
S.16LA	16	22,0	22,8	77	15	12	130
S.17LA	17	23,0	24,0	77	15	12	140
S.18LA	18	24,0	25,0	77	18	12	160
S.19LA	19	25,0	26,5	77	18	12	160
S.21LA	21	27,0	29,0	77	18	12	200
S.22LA	22	28,0	30,0	77	21	12	215
S.23LA	23	29,0	31,5	77	21	12	235
S.24LA	24	30,0	32,8	77	24	12	255
S.26LA	26	32,0	35,0	77	24	12	280
S.27LA	27	33,0	36,5	77	27	12	310
S.28LA	28	34,0	37,8	77	27	12	330
S.29LA	29	35,0	39,0	77	27	12	355
S.30LA	30	36,0	40,0	77	30	12	355
S.32LA	32	38,0	42,8	77	33	12	410

■ S.LA - 1/2" inch 12-point sockets

ASME B107.1

- OGV® profile: more powerful tightening, preserves fasteners.
- Long-reach sockets for long recess or thread access.
- Finish: bright chrome.

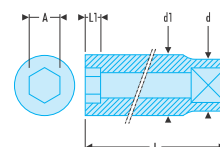

➤	A ["]	d [mm]	d1 [mm]	L [mm]	L1 [mm]	12 [mm]	ΔΔ [g]
S.1/2LA	1/2	22,3	19,0	82,2	8,1	12	135
S.9/16LA	9/16	22,3	20,6	82,2	9,6	12	140
S.5/8LA	5/8	22,3	22,3	82,2	10,9	12	150
S.11/16LA	11/16	24,4	24,4	82,2	10,9	12	160
S.3/4LA	3/4	26,9	26,9	82,2	12,4	12	165
S.13/16LA	13/16	28,7	28,7	82,2	12,9	12	175
S.7/8LA	7/8	30,2	30,2	82,2	14,0	12	200
S.15/16LA	15/16	31,7	31,7	82,2	15,0	12	225
S.1PLA	1	33,3	33,3	82,2	15,2	12	255
S.1P1/16LA	1 1/16	36,5	36,5	82,2	16,0	12	320
S.1P1/8LA	1 1/8	38,1	38,1	82,2	16,7	12	350
S.1P1/4LA	1 1/4	42,9	42,9	82,2	16,7	12	430



TORX® SOCKETS 1/2"

STX - 1/2" Torx® sockets

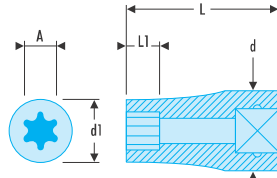

- For Torx® fasteners.
- Finish: bright chrome.
- Available as rack set Ref STX.40 (E12 --> E20) and Ref RSX.J6 (E6 --> E16).

Ref	A [mm]	d [mm]	d1 [mm]	L [mm]	L1 [mm]	Torx [No]	No.	ΔΔ [g]
STX.12	10,95	21	15,0	37	8,0	E12	E12	50
STX.14	12,67	21	16,3	37	8,8	E14	E14	50
STX.16	14,70	22	18,8	37	9,6	E16	E16	60
STX.18	16,38	22	20,4	37	11,1	E18	E18	60
STX.20	18,16	22	22,9	37	12,7	E20	E20	65
STX.24	21,84	22	26,5	37	16,1	E24	E24	100

SCREWDRIVER SOCKETS 1/2"

21-piece set of 1/4" and 1/2" Torx® sockets and bits



Comprises:

- 4 x 1/4" Torx® sockets: RTX, E6 - E7 - E8 - E10.
- 5 x 1/2" Torx® sockets: STX, E10 - E14 - E16 - E18 - E20.
- 1 x 1/4" socket bit holder with retaining pin - standard for 1/4" bits - 6.35 mm: R.235.
- 1 x 1/2" socket bit holder with retaining pin - standard for 5/16" bits - 7.94 mm: S.236.
- 7 x bits - 1/4" drive bit - 6.35 mm - L 25 mm:
 - EXR.1 for Resistorx® screws: TT 10 - TT 15 - TT 20 - TT 25 - TT 27 - TT 30 - TT 40.
- 3 x bits - 5/16" drive bit - 7.94 mm - L 35 mm:
 - EX.2 for Torx® screws: T 45 - T 50 - T 55.
- Empty case: BP.MBOXS.
- Thermoformed tray S (188 x 105 mm): PL.S05.

Ref	ΔΔ [kg]
RSX.19B	0,840

STM - 1/2" drive metric hexagon bit sockets

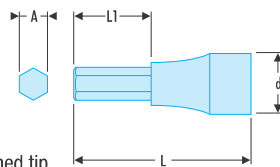

- Standard length series.
- For hexagon socket heads.
- Non-removable bit.
- Finish: bright chrome with phosphate-hardened tip.
- Available in case set (Ref STM.J9).

Ref	A [mm]	d [mm]	L [mm]	L1 [mm]	ΔΔ [g]
STM.4	4	22,8	60	24	60
STM.5	5	22,8	60	24	60
STM.6	6	22,8	60	24	60
STM.7	7	22,8	60	24	65
STM.8	8	22,8	60	24	70
STM.10	10	22,8	60	24	80
STM.12	12	23,1	60	24	100
STM.14	14	23,1	60	24	120
STM.17	17	23,4	60	24	140
STM.19	19	23,4	60	24	160

ST - 1/2" drive inch hexagon bit sockets

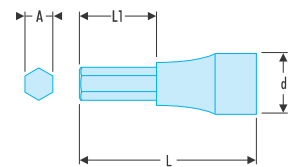

- Standard length series.
- For hexagon socket heads.
- Non-removable bit.
- Finish: bright chrome with phosphate-hardened tip.

Ref	A ["]	d [mm]	L [mm]	L1 [mm]	Socket	Bits	ΔΔ [g]
ST.1/4	1/4	23	54	17	S.236	EH.201/4	70
ST.5/16	5/16	23	54	17	S.236	EH.205/16	70
ST.3/8	3/8	23	54	17	S.236	EH.203/8	75
ST.7/16	7/16	23	70	31	S.237	ENH.307/16	110
ST.1/2	1/2	23	70	31	S.237	ENH.301/2	120
ST.9/16	9/16	23	70	31	S.237	ENH.309/16	125
ST.5/8	5/8	23	70	31	S.237	ENH.305/8	145
ST.3/4	3/4	23	70	31	S.237	ENH.303/4	165

■ SHP.LA - 1/2" drive long and extra-long reach metric hexagon bit sockets

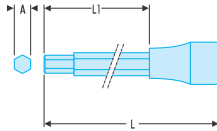

- Long and extra long reach series
- For hexagon socket heads.
- Non-removable bit.
- Finish: bright chrome with phosphate-hardened tip.

Part No.	A [mm]	L [mm]	L1 [mm]	ΔΔ [g]
SHP.6LA	6	100	64	80
SHP.7LA	7	100	64	80
SHP.8LA	8	100	64	80
SHP.10LA	10	140	104	135
SHP.12LA	12	100	64	145
SHP.5ELA	5	180	144	110
SHP.6EL1A	6	140	104	95
SHP.6EL2A	6	220	184	130

■ SXM - 1/2" drive Torx® bit sockets

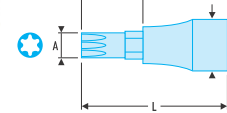

- Standard length series.
- For Torx® female drive fasteners.
- Non-removable bit.
- Finish: bright chrome with phosphate-hardened tip.
- Also available in case set (Ref AMEX.3).

Part No.	A [mm]	d [mm]	L [mm]	L1 [mm]	Torx [No]	ΔΔ [g]
SXM.20	3,84	22,8	60	24	T20	60
SXM.25	4,40	22,8	60	24	T25	60
SXM.27	4,96	22,8	60	24	T27	60
SXM.30	5,49	22,8	60	24	T30	60
SXM.40	6,60	22,8	60	24	T40	65
SXM.45	7,77	22,8	60	24	T45	65
SXM.50	8,79	22,8	60	24	T50	75
SXM.55	11,17	22,8	60	24	T55	95
SXM.60	13,17	23,1	60	24	T60	115

■ SX.LA - 1/2" drive long-reach Torx® bit sockets

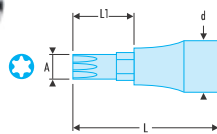

- Long-reach series.
- For Torx® female drive fasteners.
- Non-removable bit.
- Finish: bright chrome with phosphate-hardened tip.

Part No.	A [mm]	d [mm]	L [mm]	L1 [mm]	Torx [No]	ΔΔ [g]
SX.40LA	6,60	22,8	120	84	T40	95
SX.45LA	7,77	22,8	120	84	T45	95
SX.55LA	11,17	22,8	140	104	T55	220
SX.70LA	15,49	23,1	140	104	T70	280

■ D.B - Long-reach spline driver sockets

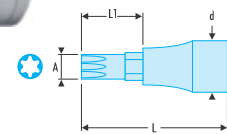

- Standard length series.
- For Torx® female drive fasteners.
- Non-removable bit.
- Finish: bright chrome with phosphate-hardened tip.

Part No.	A [mm]	d [mm]	Width l [mm]	L [mm]	L1 [mm]	ΔΔ [g]
D.34B7	7	7	60	60	15	70
D.34B7L	7	7	100	100	63	120
D.34B9L	9	9	100	100	63	130
D.34B10	10	10	60	60	15	75
D.34B12L	12	12	100	100	63	140
D.34B14L	14	14	100	100	63	150
D.34B16L	16	16	100	100	63	160

■ SV.B - 1/2" drive XZN® spline bit sockets

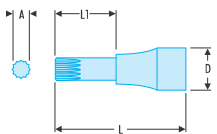

- Standard length series.
- For XZN® female drive fasteners.
- Non-removable bit.
- Finish: bright chrome with phosphate-hardened tip.

Part No.	A [mm]	d [mm]	L [mm]	L1 [mm]	ΔΔ [g]
SV.6B	M6	22,8	60	24	60
SV.8B	M8	22,8	60	24	60
SV.10B	M10	22,8	60	24	70
SV.12B	M12	22,8	60	24	80
SV.14B	M14	22,8	60	24	100
SV.16B	M16	23,1	60	24	110
SV.18B	M18	21,8	60	24	170

■ SV.LB - 1/2" drive long-reach XZN® spline bit sockets

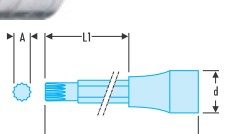

- Long and extra long reach series
- For XZN® female drive fasteners.
- Non-removable bit.
- Finish: bright chrome with phosphate-hardened tip.

Part No.	A [mm]	d [mm]	L [mm]	L1 [mm]	ΔΔ [g]
SV.6LB	M6	22,8	100	64	80
SV.8LB	M8	22,8	100	64	80
SV.10LB	M10	22,8	100	64	90
SV.10ELB	M10	22,8	120	120	110
SV.12LB	M12	22,8	100	64	120
SV.12ELB	M12	22,8	140	104	150
SV.14LB	M14	22,8	100	64	150
SV.16LB	M16	22,8	100	64	160
SV.18LB	M18	22,8	100	64	180

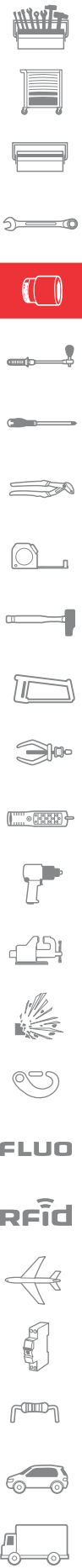

SCREWDRIVER SOCKETS 1/2"

7-piece set of 1/2" short-reach XZN® screwdriver sockets

Comprises:

- 7 x 1/2" screwdriver sockets for XZN hollow screws - L 60 mm: SV.B M6 - M8 - M10 - M12 - M14 - M16 - M18.
- Empty case: BP.MBOXS.
- Thermoformed tray S (188 x 105 mm): PL.S03.

	$\Delta\Delta$ [kg]
SV.J7A	0,925



7-piece set of 1/2" long-reach XZN® screwdriver sockets

Comprises:

- 7 x 1/2" screwdriver sockets for XZN hollow screws - L 100 mm: SV.LB M6 - M8 - M10 - M12 - M14 - M16 - M18.
- Empty case: BP.MBOXS.
- Thermoformed tray S (188 x 105 mm): PL.S03.

	$\Delta\Delta$ [kg]
SV.LJ7A	1,205



8-piece set of 1/2" short- and long-reach XZN® screwdriver sockets

Comprises:

- 4 x 1/2" screwdriver sockets for XZN hollow screws - L 60 mm: SV.B M6 - M8 - M10 - M12.
- 4 x 1/2" screwdriver sockets for XZN hollow screws - L 100 mm: SV.LB M6 - M8 - M10 - M12.
- Empty case: BP.MBOXS.
- Thermoformed tray S (188 x 105 mm): PL.S04.

	$\Delta\Delta$ [kg]
SV.J8B	0,945



6-piece set of 1/2" long-reach and extra long-reach XZN® screwdriver sockets











Comprises:

- 4 x 1/2" screwdriver sockets for XZN hollow screws - L 100 mm: SV.LB M6 - M8 - M10 - M12.
- 2 x 1/2" screwdriver sockets for XZN hollow screws - L 120 mm: SV.ELB M10 - M12.
- Empty case: BP.MBOXS.
- Thermoformed tray S (188 x 105 mm): PL.S08.

	$\Delta\Delta$ [kg]
SV.LJ6B	0,930



1/2" AND 3/4" SETS METRIC AND INCH DIMENSIONS

 Socket type mm / inch		SK.453N		SK.452N		SK.452U	
		S.161B + K.151B		S.161B + K.151B		S.161B + K.151B	
		1/2"	3/4"	1/2"	3/4"	1/2"	3/4"
		Standard sockets		Standard sockets		Standard sockets	
 mm	8	•		•			
	9	•		•			
	10	•		•			
	11	•		•			
	12	•		•			
	13	•		•			
	14	•		•			
	15	•		•			
	16	•		•			
	17	•		•			
	18	•		•			
	19	•		•			
	21	•		•			
	22	•	•		•		
	23	•		•			
	24	•	•		•		
	26	•		•			
	27	•	•		•		
	28	•		•			
	29	•		•			
30	•	•		•			
32	•	•		•			
34	•	•		•			
36	•	•		•			
41	•	•		•			
46	•	•		•			
50	•	•		•			
 inch	3/8					•	
	7/16					•	
	1/2					•	
	9/16					•	
	19/32					•	
	5/8					•	
	21/32					•	
	11/16					•	
	3/4					•	
	25/32					•	
	13/16					•	
	7/8					•	
	15/16					•	
	31/32					•	
	1'					•	
	1'1/16					•	•
	1'1/8					•	•
	1'3/16					•	•
	1'1/4					•	•
	1'3/8					•	•
1'7/16					•	•	
1'1/2					•	•	
1'5/8					•	•	
1'13/16					•	•	
2'					•	•	
 S.210	•		•		•		
 S.215	•		•		•		
 S.240A	•		•		•		
 S.120A	•		•		•		
 S.110	•		•		•		
 K.210B		•		•		•	
 K.215B		•		•		•	
 K.120B		•		•		•	



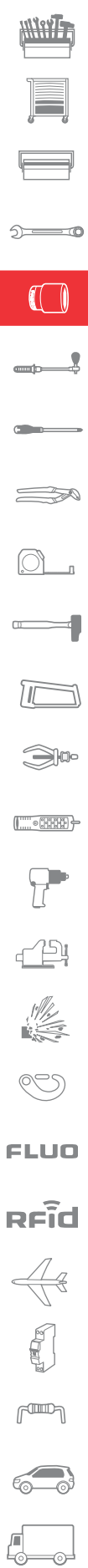

P.22
 1 x C.K422CA + 2 x CK422EA
 BT.6A
 468 x 190 x 160 mm
 17,200 Kg 16,200 Kg



FLUO

RFid

3/4" SOCKET SETS IN METAL RACKS

 Socket type	K.421N	K.420N	K.433E	K.432E	KL.411	KL.500	KL.501	K.437E	K.436E
	K.151B Standard mm	K.151B Standard mm	K.151B Standard mm	K.151B Standard mm	KL.161 Standard mm	KL.161 Standard mm	KL.161 Standard mm	K.151B Standard mm	K.151B Standard mm
mm									
19					•			•	•
21					•			•	•
22	•	•			•	•	•	•	•
23									
24	•	•			•	•	•	•	•
26									
27	•	•			•	•	•	•	•
30	•	•		•	•	•	•	•	•
32	•	•		•	•	•	•	•	•
33									
34	•	•		•	•	•	•	•	•
36	•	•		•	•	•	•	•	•
38									
41	•	•		•	•	•	•	•	•
42									
46	•	•		•	•	•	•	•	•
50	•	•		•	•	•	•	•	•
54									
55									
K.210B	•	•	•	•	•	•	•	•	•
K.215B	•	•	•	•	•	•	•	•	•
K.240A									
K.120B	•	•	•	•	•	•	•	•	•
 	PL.42	PL.42	PL.40	PL.40	PL.438	-	-	PL.87A	PL.87A
	BT.103							BT.103	BT.103
	643 x 230 x 111 mm						BV.COMPO-KA	643 x 230 x 111 mm	643 x 230 x 111 mm
	12,900 Kg		16,300 Kg		15,200 Kg	14,900 Kg		15,500 Kg	

K.421N



K.433E



K.420N



K.432E



KL.500



KL.411



K.436E















KL.501



K.437E



SETS OF 3/4" METRIC METAL, PLASTIC AND THERMOFORMED

		K.441A	K.442A	SK.453N	SK.452N	MOD.K1	MOD.KL2	K.415E	K.405E
		K.151B	K.151B	K.151B	K.151B	K.151B	KL.161	K.151B	-
		Standard	Standard	Standard	Standard	Standard	Standard	Long	Long
Socket type		3/4"	3/4"	1/2" 3/4"	1/2" 3/4"	3/4"	3/4"	3/4"	3/4"
mm									
	8			•	•				
	9			•	•				
	10			•	•				
	11			•	•				
	12			•	•				
	13			•	•				
	14			•	•				
	15			•	•				
	16			•	•				
	17			•	•				
	18			•	•				
	19	•	•	•	•				
	21	•	•	•	•				
	22	•	•	•	•			•	•
	23	•	•	•	•			•	•
	24	•	•	•	•			•	•
	26			•	•			•	•
	27	•	•	•	•			•	•
	28			•	•			•	•
	29			•	•			•	•
	30	•	•	•	•			•	•
	32	•	•	•	•			•	•
	33			•	•			•	•
	34	•	•	•	•	•	•	•	•
	36	•	•	•	•	•	•	•	•
	38	•	•	•	•	•	•	•	•
	41	•	•	•	•	•	•	•	•
	42			•	•			•	•
	46	•	•	•	•	•	•	•	•
	50	•	•	•	•	•	•	•	•
	54			•	•			•	•
	55	•	•	•	•	•	•	•	•
	K.210B	•	•	•	•	•	•	•	•
	K.215B	•	•	•	•	•	•	•	•
	K.240A	•	•	•	•	•	•	•	•
	K.120B	•	•	•	•	•	•	•	•
	K.125A	•	•	•	•	•	•	•	•
	K.140A	•	•	•	•	•	•	•	•
	K.230B	•	•	•	•	•	•	•	•
	S.210			•	•				
	S.215			•	•				
	S.240A			•	•				
	S.120A			•	•				
	S.110			•	•				
		-	-	P.22		PL.324	PL.662A	PL.43	PL.60A
		1 x C.K422CA + 2 x CK422EA				-	-	-	-
		BT.6A				-	-	BT.103G	BT.111
		468 x 190 x 160 mm				396 x 224 x 84	410 x 188 x 84	643 x 230 x 111	396 x 224 x 82
		17,000 Kg		17,200 Kg		7,700 Kg	7,200 Kg	16,270 Kg	9,300 Kg

K.441A



SK.453N



SK.452N



MOD.K1



MOD.KL2



K.415E



K.405E

















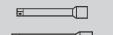

FLUO

Rfid

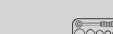
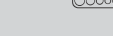

3/4" SOCKET SETS IN METAL RACKS

  Socket type	 K.442U K.151B  Inch Standard 3/4"		 SK.452U K.161B + K.151B  Inch Standard 1/2" 3/4"	
	mm			
	3/8		•	
	7/16		•	
	1/2		•	
	9/16		•	
	19/32		•	
	5/8		•	
	21/32		•	
	11/16		•	
	3/4	•	•	
	25/32		•	
	13/16		•	
	7/8	•	•	
	15/16	•	•	
	31/32		•	
	1"	•	•	
	1 1/16	•		•
	1 1/8	•		•
	1 3/16		•	
	1 1/4	•	•	•
	1 5/16	•		•
	1 3/8	•		•
	1 7/16	•		•
	1 1/2	•		•
	1 5/8	•		•
	1 11/16	•		•
	1 3/4	•		•
	1 13/16	•		•
	1 7/8	•		•
	2"	•		•
	2 1/8	•		
	2 3/16	•		
	2 1/4	•		
	S.210		•	
	S.215		•	
	S.240A		•	
	S.120A		•	
	S.110		•	
	K.210B	•		•
	K.215B	•		•
	K.120B	•		•
	K.125A	•		
	K.140A	•		
	-		P.22	
	1 x C.K422CA + 2 x CK422EA			
	BT.6A			
	468 x 190 x 160 mm			
	22,100 Kg		16,200 Kg	

K.442U

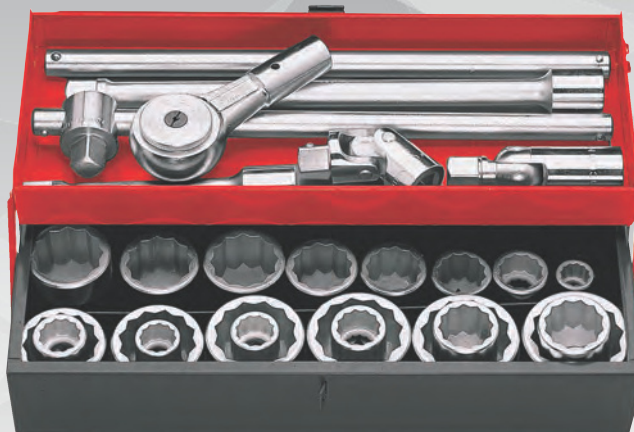

SK.452U

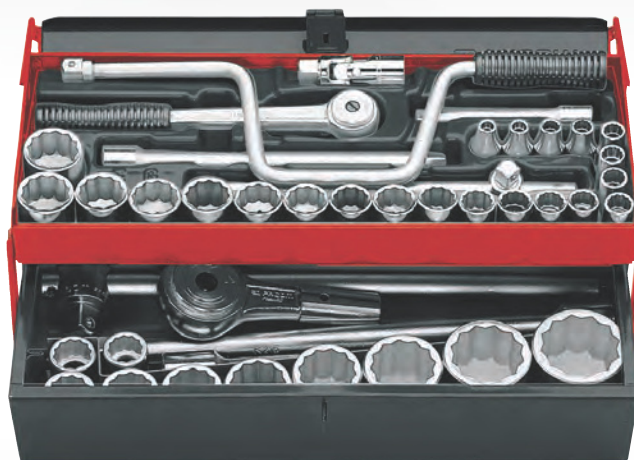

RATCHETS 3/4"

RATCHET 3/4" KL.161



Extremely compact and lightweight ratchet for difficult access

- One-piece ratchet and hands ergonomic grip: allows applying more strength
- Dustproof for greater lifetime
- Precision: 120 teeth mechanism for 3° increments
- Reverse lever: easy even with gloved hand.



High performance sealed 3/4" ratchet



NF ISO 3315, ISO 3315, DIN 3122, ASME B107.10

- Very long durability regardless of working conditions. Maintenance-free. Mechanism sealed to industrial dust.
- 120 tooth mechanism for 3° increments.
- Lever reversing: easy even when wearing gloves. Visible rotation direction.
- "Palm control" system, to press the ratchet head when tightening or loosening without risk of accidental reversing of the rotation direction.
- Ultra-compact head.
- Bi-material elastomer grip: high resistance to abrasion and the most severe workshop solvents: SP95, SP98, diesel fuel, acetone, brake fluid, Skydrol, Jet Oil, kerosene.
- Hole in the handle for strapping when working in high places.
- Finish: mat chrome.



	d [mm]	d1 [mm]	H [mm]	L [mm]	L1 [mm]	ΔΔ [kg]
KL.161	60	31/35	52	512	481	1.47

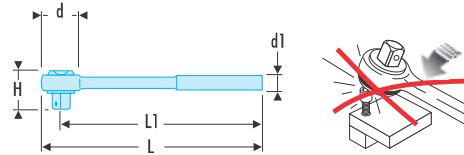

3/4" drive ratchet with removable handle



- 72 teeth mechanism for 5° increments.
- Rotating cap inversion.
- Safety lock by diver.
- Removable handle K.154AM.
- Single-material elastomer handle: high resistance to abrasion and solvents in the most severe conditions: fuel, diesel, gasoline, acetone, brake fluid, Skydrol, Jet Oil, kerosene
- Satin chrome finish



	d [mm]	d1 [mm]	d2 [mm]	d3 [mm]	H [mm]	H1 [mm]	L [mm]	L1 [mm]	ΔΔ [kg]
K.154B	68	40	30	20	61	37	548	514	2.4

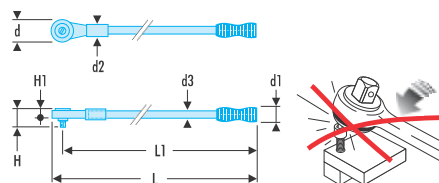

RATCHETS - SOCKETS

3/4" drive ratchet without handle

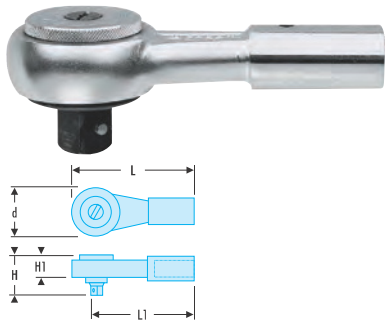

NF ISO 3315, ISO 3315, DIN 3122, ASME B107.10

- Precise increment: 5°.
- 72-tooth mechanism.
- For use with bars K.125 or K.126 and handle K.154AM.
- Plunger lock.
- Bi-material elastomer grip: high resistance to abrasion and the most severe workshop solvents: SP95, SP98, diesel fuel, acetone, brake fluid, Skydrol, Jet Oil, kerosene.
- Finish: chromed.



	d [mm]	H [mm]	H1 [mm]	L [mm]	L1 [mm]	ΔΔ [kg]
K.151B	68	61	37	170	136	1.2

3/4" drive "heavy duty" ratchet

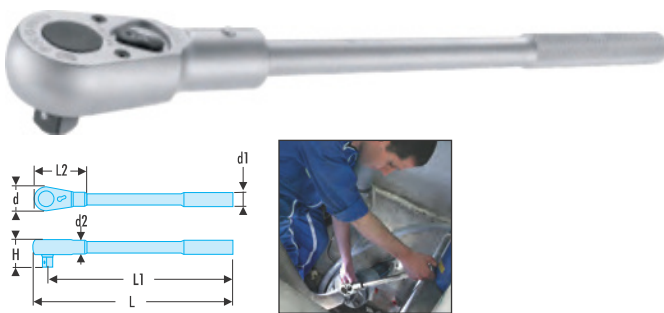

NF ISO 3315, ISO 3315, DIN 3122, ASME B107.10

- Suitable for outdoor working:
 - Sturdy mechanism protected against dirt.
 - Recessed reversing switch.
 - 9° increments.
 - 40 tooth mechanism.
 - Removable handle K.149M..
- Plunger lock.
- Finish: mat chrome.



	d [mm]	d1 [mm]	d2 [mm]	H [mm]	L [mm]	L1 [mm]	ΔΔ [kg]
K.149	65,5	25	32	62	510	475	2,9

Handle for 3/4" ratchet K.151B



- Handle for 3/4" ratchets Ref K.154B and K.151B
- Single material elastomer grip: high resistance to abrasion and the most severe workshop solvents: SP95, SP98, diesel fuel, acetone, brake fluid, Skydrol, Jet Oil, kerosene.
- Satin chrome finish.



	ΔΔ [kg]
K.154AM	1.130

MAINTENANCE OF 3/4" RATCHETS

- Ratchet maintenance is straightforward: for continued serviceability, simply clean and replace worn parts periodically.

	K.151	K.151A	K.151B	K.154A	K.154B	K.149
Caps						
M.151C	•					
K.151BC		•	•	•	•	
Spare part kit						
K.151RN	•	•	•	•	•	
Rotors						
K.150AR						
K.151AR		•	•	•	•	
Repair kit						
K.149RN						•

ACCESSORIES 3/4"

K.A - Bar for 3/4" ratchet



- For use as extension handles on ratchet K.151B, as well as on handles K.140A and K.200E.
- Finish: satin chrome.

Part No.	d [mm]	L [mm]	ΔΔ [kg]
K.125A	20	425	1.0
K.126A	20	500	1.2

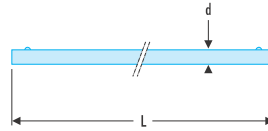

3/4" drive sliding tee



NF ISO 3315, ISO 3315, DIN 3122, ASME B107.10

- Ball-steadied head.
- T or L-handle.
- Finish: satin chrome.

Part No.	d [mm]	d1 [mm]	H [mm]	H1 [mm]	L [mm]	ΔΔ [kg]
K.120B	36	20	62	37	425	1.3

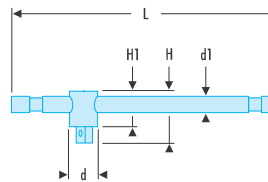

3/4" drive fixed adaptor



- For use with bars K.125A or K.126A.
- For power loosening without damaging the ratchet.
- Finish: satin chrome.

Part No.	d [mm]	d1 [mm]	H [mm]	L [mm]	ΔΔ [g]
K.200E	35	30	40	152	630

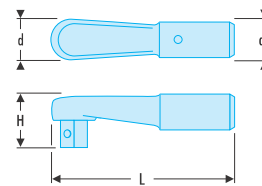

3/4" drive hinged adaptor



- For use with bars K.125 or K.126.
- Fastener rotation from any angle over 180°.
- Joint 180°.
- Spring-steadied in any position.
- Finish: satin chrome.

Part No.	d [mm]	d1 [mm]	H [mm]	H1 [mm]	L [mm]	ΔΔ [g]
K.140A	40	20	70	46	125	760

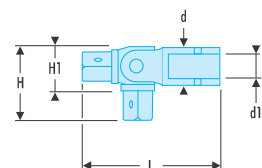

FLUO

Rfid



ACCESSORIES 3/4"

■ K.B - 3/4" drive extensions

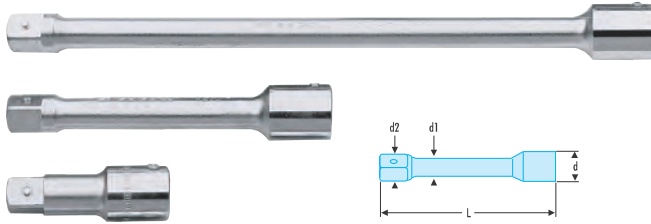

NF ISO 3316, ISO 3316, DIN 3123, ASME B107.10

- Ideal when space is at a premium with multiple extensions sizes
- Satin chrome finish



🔧	C [mm]	d [mm]	d1 [mm]	d2 [mm]	L [mm]	ΔΔ [g]
K.208B	25	36	25	25	100	410
K.210B	25	36	20	25	200	620
K.215B	25	36	20	25	400	1100

■ 3/4" universal joint



NF ISO 3316, ISO 3316, DIN 3123, ASME B107.10

- Spring-stiffened joints.
- Significant time savings.
- Finish: satin chrome.



🔧	d [mm]	L [mm]	L1 [mm]	ΔΔ [g]
K.240A	40	105	82	550

■ 3/4" to 1/2" coupler

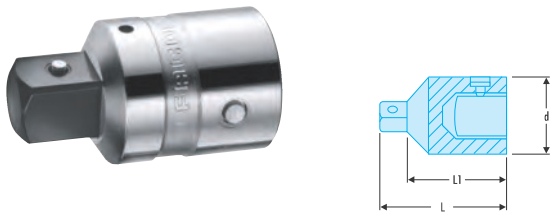

NF ISO 3316, ISO 3316, DIN 3123, ASME B107.10

- For adapting sockets and accessories 1/2".
- Interchangeable 1/2" male square ref. K.230B1.
- Max. torque 512 N.m.
- Finish: satin chrome, phosphate square.



🔧	d [mm]	L [mm]	L1 [mm]	ΔΔ [g]
K.230B	36	58,5	43	250

■ Interchangeable 1/2" male drive



- Interchangeable 1/2" male drive for 3/4" to 1/2" coupler reference K.230B.
- Finish: satin chrome.



🔧	ΔΔ [g]
K.230B1	35

■ 3/4" to 1" coupler

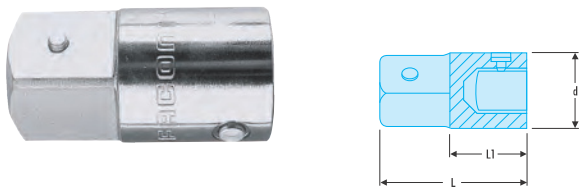

NF ISO 3316, ISO 3316, DIN 3123, ASME B107.10

- For adapting sockets and accessories 1".
- Finish: satin chrome.



🔧	d [mm]	L [mm]	L1 [mm]	ΔΔ [g]
K.232A	36	67	39	340

LOCKING SOCKETS AND ACCESSORIES 3/4" - 1"

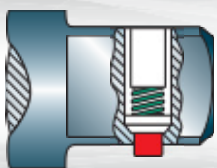

Safety and comfort !

- Lock system prevents accidental socket loss during use.
- Quick release simply by pressing the plunger.
- Compatible with the standard ball-lock tools.



SOCKETS 3/4"

■ K.HB 3/4" drive metric 6-point sockets

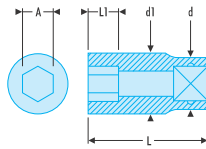

NF ISO 2725-1, NF ISO 1711-1, ISO 2725-1, ISO 1711-1, DIN 3124, ASME B107.5

- OGV® profile: more powerful tightening, preserves fasteners.
- Secure attachment of plunger lock accessories
- Quick release button.
- Finish: satin chrome.

➤	A [mm]	d [mm]	d1 [mm]	L [mm]	L1 [mm]	6 [mm]	ΔΔ [g]
K.19HB	19	36	30,1	51,0	14	6	207
K.21HB	21	36	32,0	51,0	14	6	208
K.22HB	22	36	33,4	51,0	14	6	221
K.23HB	23	36	36,0	52,5	14	6	244
K.24HB	24	36	36,0	52,5	16	6	237
K.26HB	26	36	38,9	52,5	16	6	231
K.27HB	27	36	39,7	52,5	18	6	232
K.28HB	28	36	41,0	52,5	18	6	239
K.29HB	29	36	42,0	52,5	18	6	245
K.30HB	30	36	43,2	59,0	20	6	282
K.32HB	32	36	45,9	59,0	22	6	301
K.33HB	33	36	48,1	59,0	22	6	330
K.34HB	34	36	48,4	59,0	24	6	322
K.35HB	35	36	50,1	59,0	24	6	344
K.36HB	36	36	51,0	59,0	24	6	347
K.38HB	38	40	54,3	66,9	27	6	478
K.40HB	40	40	56,0	66,9	27	6	493
K.41HB	41	40	57,3	66,9	27	6	504
K.42HB	42	40	59,5	66,9	27	6	552
K.43HB	43	40	60,7	66,9	27	6	560
K.44HB	44	40	61,9	66,9	28	6	587
K.46HB	46	40	63,5	75,0	30	6	641
K.50HB	50	40	68,5	75,0	33	6	725
K.54HB	54	45	74,0	75,0	36	6	880
K.55HB	55	45	74,7	75,0	36	6	875

■ K.B 3/4" drive metric 12-point sockets

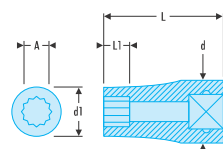

NF ISO 2725-1, NF ISO 1711-1, ISO 2725-1, ISO 1711-1, DIN 3124, ASME B107.5

- OGV® profile: more powerful tightening, preserves fasteners.
- Secure attachment of plunger lock accessories
- Quick release button.
- Finish: satin chrome.

➤	A [mm]	d [mm]	d1 [mm]	L [mm]	L1 [mm]	6 [mm]	ΔΔ [g]
K.19B	19	36	30,1	51,0	14	12	207
K.21B	21	36	32,0	51,0	14	12	208
K.22B	22	36	33,4	51,0	14	12	221
K.23B	23	36	36,0	52,5	14	12	244
K.24B	24	36	36,0	52,5	16	12	237
K.26B	26	36	38,9	52,5	16	12	231
K.27B	27	36	39,7	52,5	18	12	232
K.28B	28	36	41,0	52,5	18	12	239
K.29B	29	36	42,0	52,5	18	12	245
K.30B	30	36	43,2	59,0	20	12	282
K.32B	32	36	45,9	59,0	22	12	301
K.33B	33	36	48,1	59,0	22	12	330
K.34B	34	36	48,4	59,0	24	12	322
K.35B	35	36	50,1	59,0	24	12	344
K.36B	36	36	51,0	59,0	24	12	347
K.38B	38	40	54,3	66,9	27	12	478
K.40B	40	40	56,0	66,9	27	12	493
K.41B	41	40	57,3	66,9	27	12	504
K.42B	42	40	59,5	66,9	27	12	552
K.43B	43	40	60,7	66,9	28	21	301
K.44B	44	40	61,9	66,9	28	12	587
K.46B	46	40	63,5	75,0	30	12	641
K.50B	50	40	68,5	75,0	33	12	725
K.54B	54	45	74,0	75,0	36	12	880
K.55B	55	45	74,7	75,0	36	12	875

■ K.B 3/4" drive inch 12-point sockets

ASME B107.1

- OGV® profile: more powerful tightening, preserves fasteners.
- Secure attachment of plunger lock accessories
- Quick release button.
- Finish: satin chrome.

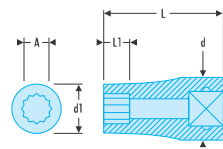

➤	A ["]	d [mm]	d1 [mm]	L [mm]	L1 [mm]	6 [mm]	ΔΔ [g]
K.3/4B	3/4	36	30,1	51,0	14	12	207
K.7/8B	7/8	36	33,6	51,0	14	12	220
K.15/16B	15/16	36	35,7	52,5	14	12	233
K.1PB	1"	36	38,0	52,5	14	12	250
K.1P1/16B	1 1/16"	36	39,7	52,5	18	12	232
K.1P1/8B	1 1/8"	36	41,6	52,5	18	12	241
K.1P3/16B	1 3/16"	36	43,2	59,0	20	12	280
K.1P1/4B	1 1/4"	36	45,9	59,0	22	12	304
K.1P5/16B	1 5/16"	36	48,1	59,0	22	12	326
K.1P3/8B	1 3/8"	36	50,1	59,0	24	12	343
K.1P7/16B	1 7/16"	36	51,0	59,0	24	12	339

➤	A ["]	d [mm]	d1 [mm]	L [mm]	L1 [mm]	6 [mm]	ΔΔ [g]
K.1P1/2B	1 1/2"	40	54,3	66,9	27	12	478
K.1P9/16B	1 9/16"	40	56,0	66,9	27	12	498
K.1P5/8B	1 5/8"	40	57,3	66,9	27	12	498
K.1P11/16B	1 11/16"	40	60,7	66,9	27	12	564
K.1P3/4B	1 3/4"	40	62,2	66,9	28	12	586
K.1P13/16B	1 13/16"	40	63,5	75,0	30	12	641
K.1P7/8B	1 7/8"	40	66,2	75,0	33	12	699
K.2PB	2"	40	68,5	75,0	33	12	698
K.2P1/8B	2 1/8"	45	74,0	75,0	36	12	880
K.2P3/16B	2 3/16"	45	74,7	75,0	36	12	855
K.2P1/4B	2 1/4"	45	77,1	75,0	36	12	913

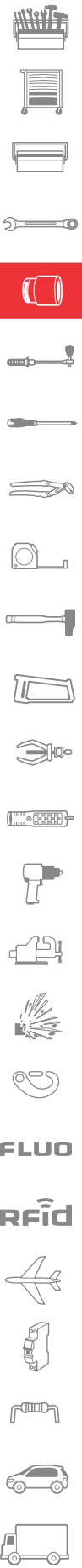

SOCKETS 3/4"

■ K.LA 3/4" long-reach metric 6-point sockets

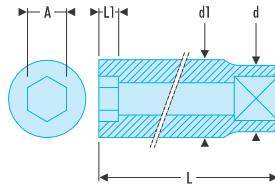

NF ISO 2725-1, NF ISO 1711-1, ISO 2725-1, ISO 1711-1, DIN 3124, ASME B107.5

- OGV® profile: more powerful tightening, preserves fasteners.
- Secure attachment of plunger lock accessories
- Quick release button.
- Finish: satin chrome.



➤	A [mm]	d [mm]	d1 [mm]	L [mm]	L1 [mm]	⊕ [mm]	ΔΔ [g]
K.19LA	19	36	30,1	90	18	6	339
K.21LA	21	36	32,0	90	18	6	367
K.22LA	22	36	33,4	90	21	6	391
K.23LA	23	38	36,0	90	21	6	461
K.24LA	24	38	36,0	90	24	6	400
K.26LA	26	36	38,9	90	24	6	474
K.27LA	27	38	39,7	90	27	6	480
K.29LA	29	40	42,0	90	27	6	505
K.30LA	30	40	43,2	90	30	6	530
K.32LA	32	40	45,9	90	33	6	540
K.33LA	33	45	48,1	90	33	6	600
K.34LA	34	45	48,4	90	33	6	656
K.35LA	35	45	50,1	90	33	6	707
K.36LA	36	45	51,0	90	36	6	672
K.38LA	38	45	54,3	90	36	6	772
K.41LA	41	45	57,3	90	40	6	778
K.42LA	42	45	59,5	90	40	6	863

■ KT.A 3/4" drive metric bits for hexagon socket heads

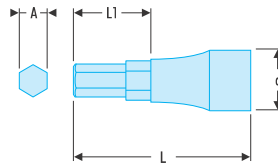

- Interchangeable bits with plunger lock.
- Finish: chrome with phosphate bit.



➤	A [mm]	d [mm]	L [mm]	L1 [mm]	ΔΔ [g]
KT.14A	14	36	74,5	25	297
KT.17A	17	36	74,5	25	307
KT.19A	19	36	74,5	25	314
KT.22A	22	36	74,5	25	314

MAMMOTH 1" RANGE

RATCHETS AND ACCESSORIES 1"

■ 1" drive ratchet without handle

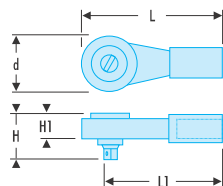

NF ISO 3315, ISO 3315, DIN 3122, ASME B107.10

- 5° increment.
- 72-tooth mechanism.
- For use with bars M.125 or M.126 and handle M.120.
- Finish: satin chrome.
- Présentation : chromée satinée.



➤	d [mm]	H [mm]	H1 [mm]	L [mm]	L1 [mm]	ΔΔ [kg]
M.151	73	77	45	197	161	2.1

M.A - Bars for 1" ratchet M.151

- Used as extension handles on ratchet M.151.
- Finish: satin chrome.



	d [mm]	L [mm]	ΔΔ [kg]
M.125A	25	500	1.9
M.126A	25	700	2.7

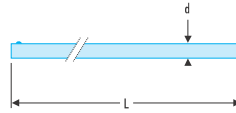

1" drive sliding tee

- NF ISO 3315, ISO 3315, DIN 3122, ASME B107.10
- Friction-head allows bar to form a T or L-handle.
 - Fitted with a lock by plunger.
 - Finish: satin chrome.



	d [mm]	d1 [mm]	H [mm]	H1 [mm]	L [mm]	[kg]
M.120A	25	42	79	49,5	500	2.4

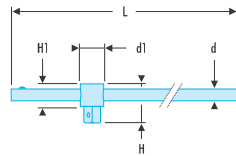

M.A - 1" drive extensions

- NF ISO 3315, ISO 3315, DIN 3122, ASME B107.10
- Safety plunger lock.
 - Finish: satin chrome.



	A [mm]	C [mm]	d [mm]	d1 [mm]	L [mm]	ΔΔ [kg]
M.210A	33	33	48	25	200	1.1
M.215A	33	33	48	25	415	2.0

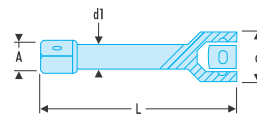

1" to 3/4" coupler

- NF ISO 3316, ISO 3316, DIN 3123
- For adapting 3/4" drive sockets.
 - Interchangeable 3/4" male square ref. M.230C1.
 - Finish: satin chrome, with burnished square.



	ΔΔ [kg]
M.230C	0,415

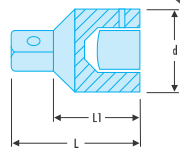

Interchangeable 3/4" male drive

- Maximum torque 1412 N.m.
- Interchangeable 1/3" male square attaches to 1" to 3/4" coupler reference M.230C.



	ΔΔ [kg]
M.230C1	110

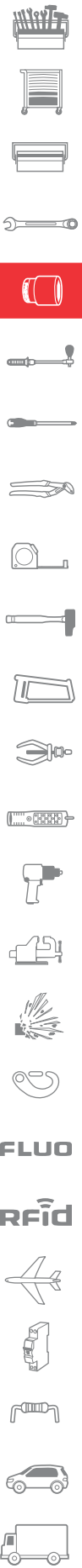

1" SOCKETS

M.HA - 1" drive metric 6-point sockets

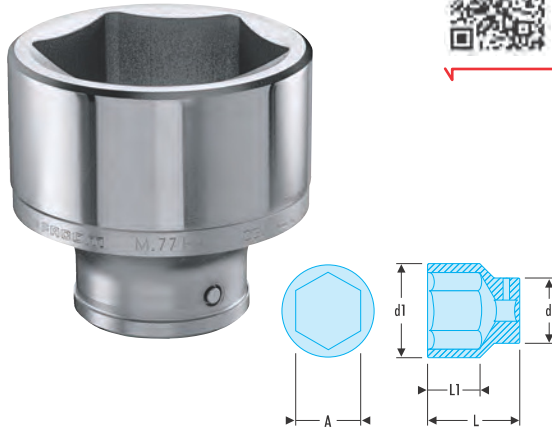

NF ISO 2725-1, NF ISO 1711-1, ISO 2725-1, ISO 1711-1, DIN 3124

- Thinner, lighter body.
- Secure attachment of plunger lock accessories.
- Push-button release.
- Finish: satin chrome.

Part No.	A [mm]	d [mm]	d1 [mm]	L [mm]	L1 [mm]	6 [mm]	ΔΔ [kg]
M.41HA	46	51,3	64,4	76	30	6	0,850
M.46HA	41	51,3	56,9	74	25	6	0,685
M.50HA	50	51,3	69,4	80	33	6	0,970
M.54HA	54	56,3	74,4	84	31	6	1,260
M.55HA	55	56,3	75,4	84	36	6	1,260
M.58HA	58	56,3	79,6	85	35	6	1,350
M.60HA	60	56,3	82,4	87	39	6	1,430
M.63HA	63	58,3	85,4	92	35	6	1,545
M.65HA	65	58,3	88,4	92	42	6	1,650
M.67HA	67	58,3	90,4	92	39	6	1,690
M.70HA	70	56,3	95,0	96	45	6	1,920
M.71HA	71	56,3	96,0	96	45	6	1,900
M.75HA	75	63,3	101,0	100	48	6	2,260
M.77HA	77	63,3	108,0	100	51	6	2,750
M.80HA	80	63,3	108,0	106	52	6	2,800
M.82HA	82	63,3	110,8	110	52	6	2,880
M.85HA	85	71,3	114,0	110	52	6	3,225
M.90HA	90	71,3	121,0	110	56	6	3,555
M.95HA	95	71,3	127,0	110	56	6	3,800
M.100HA	100	71,3	133,0	115	56	6	4,225

M.HA - 1" drive inch 6-point sockets

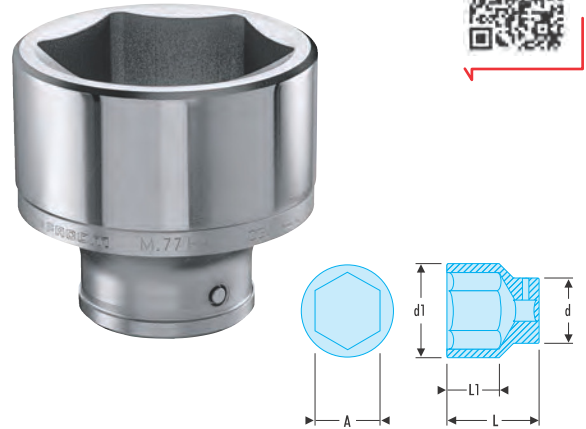

ASME B107.1

- Thinner, lighter body.
- Secure attachment of plunger lock accessories.
- Push-button release.
- Finish: satin chrome.

Part No.	A ["]	d [mm]	d1 [mm]	L [mm]	L1 [mm]	6 [mm]	ΔΔ [kg]
M.1P7/8HA	1" 7/8	51,3	70,4	80	31	6	1,0
M.2PHA	2"	56,3	74,4	84	31	6	1,260
M.2P1/8HA	2" 1/8	56,3	74,4	84	31	6	1,3
M.2P3/16HA	2" 3/16	56,3	75,4	84	35	6	1,3
M.2P1/4HA	2" 1/4	56,3	78,5	84	35	6	1,4
M.2P3/8HA	2" 3/8	56,3	82,4	87	39	6	1,4
M.2P1/2HA	2" 1/2	58,3	86,4	92	35	6	1,6
M.2P5/8HA	2" 5/8	58,3	90,4	92	39	6	1,7
M.2P3/4HA	2" 3/4	94,4	58,3	96	45	6	1,9
M.3PHA	3"	65,3	103,4	100	51	6	2,4
M.3P1/8HA	3" 1/8	65,3	107,4	106	51	6	2,8
M.3P3/8HA	3" 3/8	73,3	113,4	110	56	6	3,2

1" drive 12-point sockets



ASME B107.1

- Thinner, lighter body.
- Secure attachment of plunger lock accessories.
- Push-button release.
- Finish: chromed.

Part No.	A [mm]	d [mm]	d1 [mm]	L [mm]	L1 [mm]	12 [mm]	ΔΔ [kg]
M.65B	65	58,3	85,4	92	42	12	1,7

1" METRIC SOCKET SETS

Set of 1" drive 6-point sockets 42 to 82 mm



- Including:
- Ratchet: M.151.
- Sockets: M.46HA - M.50HA - M.54HA - M.55HA - M.58HA - M.60HA - M.63HA - M.65HA - M.67HA - M.70HA - M.71HA - M.75HA - M.77HA - M.80HA - M.82HA - M46HA-M1P13/16HA.
- Accessories: M.120A - M.210A - M.215A.
- Metal case BT.101
- Tray PL.57.

🔧	H [mm]	P [mm]	L [mm]	ΔΔ [kg]
M.431E	158	344	768	46.5

Set of 1" drive 6-point sockets 41 to 80 mm



- Including:
- 1 x Ratchet: M.151.
- 15 x Sockets: M.58HA - M.60HA - M.63HA - M.65HA - M.67HA - M.70HA - M.71HA - M.75HA - M.77HA - M.80HA - M.82HA - M.85HA - M.90HA - M.95HA - M.100HA.
- Accessories: M.120A - M.210A - M.215A.
- Metal case BT.104, dim.
- Tray PL.85.

🔧	H [mm]	P [mm]	L [mm]	ΔΔ [kg]
M.423E	123	344	568	29.7

1" INCH SOCKET SETS

Set of 1" drive 6-point sockets 58 to 100 mm



- Including:
- Ratchet: M.151.
- Sockets: M.58HA - M.60HA - M.63HA - M.65HA - M.67HA - M.70HA - M.71HA - M.75HA - M.77HA - M.80HA - M.82HA - M.85HA - M.90HA - M.95HA - M.100HA.
- Accessories: M.120A - M.210A - M.215A.
- Metal case BT.101.
- Tray PL.54.

🔧	H [mm]	P [mm]	L [mm]	ΔΔ [kg]
M.441E	158	344	768	63.1

Set of 1" drive sockets 17/8" to 33/8"



- Including:
- 1 x Ratchet: M.151.
- 12 x Sockets: M.17/8HA - M.21/2HA - M.21/4HA - M.23/16HA - M.23/4HA - M.23/8HA - M.25/8HA - M.2"HA - M.31/8HA - M.33/8HA - M.3"HA - M.21/8HA.
- Accessories: M.120A - M.210A - M.215A.
- Metal case BT.101.
- Tray PL.58.

🔧	H [mm]	P [mm]	L [mm]	ΔΔ [kg]
M.431U	344	158	768	29.7

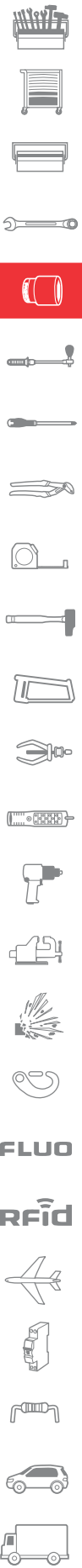

FLUO

Rfid

IMPACT SOCKETS 3/8"

IMPACT SOCKETS AND ACCESSORIES

Developed for your power tools

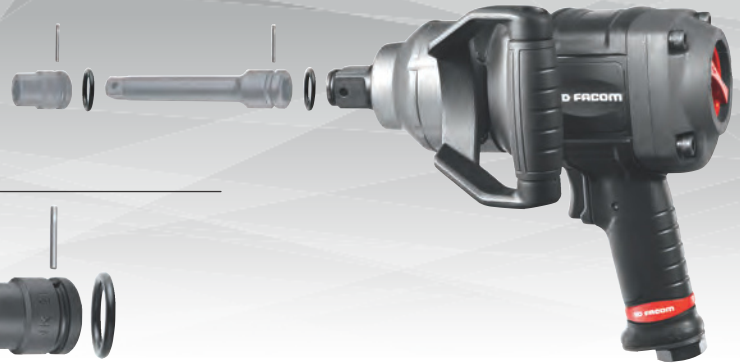

Pins	Ø	L (mm)
GA.15B	2,5	14,8
GA.18B	2,5	17,8
GA.19B	2,5	19,0
GA.20B	3,0	20,0
GA.22B	3,0	22,0
GA.25B	3,0	25,0
GA.31B	4,0	31,0
GA.35B	4,0	35,0
GA.45B	5,0	45,0
GA.77B	5,0	77,0
GA.75B	6,0	75,0
GA.84B	6,0	84,0

Rings	Ø	L (mm)
BA.15B	3,5	15,0
BA.18B	3,5	18,0
BA.19B	3,5	19,0
BA.20B	4,0	20,0
BA.22B	4,0	22,0
BA.25B	4,0	25,0
BA.30B	5,0	30,0
BA.36B	5,0	36,0
BA.45B	7,0	45,0
BA.76B	7,0	76,0
BA.74B	10,0	74,0
BA.84B	10,0	84,0









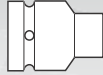

Performance

• Specially designed to resist the stresses from impact (section 14). Their special steel and heat treatment ensure a very high yield strength and wear resistance.

Safety

• All sockets and accessories feature a groove and side-hole to UNI ISO 2725. Locking is ensured by a through-pin and retaining ring (to be ordered separately). Never fit chrome-finished manual sockets Impact tools.

CHOOSING IMPACT TOOLS

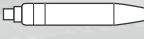
TYPE OF TOOL	DRIVE	SIZES
Sockets 	☑ 3/8" ☑ 1/2" ☑ 3/4" ☑ 1" ☑ 1 1/2"	6 > 19 mm 8 > 36 mm ; 3/8" > 1" 1/16 12 16 > 22 mm 17 > 46 mm ; 3/4" > 1" 5/8 22 > 77 mm 55 > 120 mm
TORX® 	☑ 1/2"	E10 > E24
TORX® Long-reach 	☑ 1/2" ☑ 3/4"	E10 > E24
Socket 	☑ 1/2" ☑ 3/4" ☑ 1"	6 8 > 32 mm 12 8 > 36 mm 17 > 46 mm 22 > 70 mm 17 > 46 mm
Long-reach socket 	☑ 1"	32 - 33 mm
Extra-long-reach socket 	☑ 1/2"	
Monobloc bit 	☑ 3/4"	
Monobloc bit 	☑ 3/8" ☑ 1/2" ☑ 3/4" ☑ 1" ☑ 1 1/2"	Universal joint
1 model per drive 	☑ 3/8" ☑ 1/2" ☑ 3/4" ☑ 1" ☑ 1 1/2"	☑ 3/8" > ☑ 1/2" ☑ 1/2" > ☑ 3/4" ☑ 1/2" > ☑ 3/8" ☑ 3/4" > ☑ 1" ☑ 3/4" > ☑ 1/2" ☑ 1" > ☑ 1 1/2" ☑ 1" > ☑ 3/4" ☑ 1 1/2" > ☑ 2" 1/2" ☑ 1 1/2" > ☑ 1"
Coupler Impact screwdrivers 	☑ 3/8" ☑ 1/2"	200 Nm 400 Nm

NJ.A - 3/8" drive metric 6-point impact sockets

NF ISO 2725-2, NF ISO 1711-2, ISO 2725-2, ISO 1711-2, DIN 3129, ASME B107.33

• For your safety, use impact sockets and accessories with the appropriate rings and pins.

Socket	A [mm]	BA	GA	d [mm]	d1 [mm]	H3 [mm]	L [mm]	L1 [mm]	6 [mm]	ΔΔ [g]
NJ.6A	6	BA.15B	GA.15B	20	11,5	6	30	4,0	6	40
NJ.7A	7	BA.15B	GA.15B	20	12,5	8	30	4,0	6	45
NJ.8A	8	BA.15B	GA.15B	20	14,0	8	30	5,2	6	45
NJ.9A	9	BA.15B	GA.15B	20	15,0	8	30	5,0	6	45
NJ.10A	10	BA.15B	GA.15B	20	16,5	8	30	6,0	6	45
NJ.11A	11	BA.15B	GA.15B	20	17,5	9	30	7,0	6	50
NJ.12A	12	BA.15B	GA.15B	20	19,0	9	30	8,0	6	50
NJ.13A	13	BA.18B	GA.18B	22	20,0	10	30	8,0	6	50
NJ.14A	14	BA.18B	GA.18B	22	21,5	11,5	30	10,0	6	65
NJ.15A	15	BA.18B	GA.18B	22	22,0	11	30	10,0	6	70
NJ.16A	16	BA.18B	GA.18B	22	24,0	12,5	30	10,0	6	70
NJ.17A	17	BA.18B	GA.18B	22	26,0	12,5	30	10,0	6	70
NJ.18A	18	BA.18B	GA.18B	22	26,0	12,5	30	12,0	6	75
NJ.19A	19	BA.18B	GA.18B	22	27,8	14	30	12,0	6	80

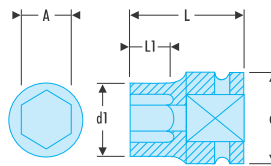

NJ.A - 3/8" drive impact extensions

ASME B107.2

• For your safety, use impact extensions and accessories with the appropriate rings and pins.

Socket	BA	GA	d [mm]	L [mm]	ΔΔ [g]
NJ.210A	BA.16A	GA.15A	19	75	95
NJ.211A	BA.16A	GA.15A	19	150	170

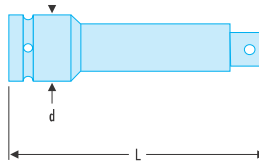

3/8" drive impact universal joint

ASME B107.2

• For your safety, use impact universal joints with the appropriate rings and pins.

Socket	BA	GA	d [mm]	L [mm]	ΔΔ [g]
NJ.240A	BA.19B	GA.19B	24	51	85

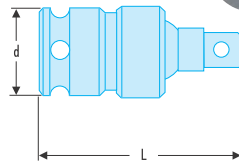

3/8" to 1/2" impact coupler

• For your safety, use impact couplers with the appropriate rings and pins.

Socket	d [mm]	L [mm]	ΔΔ [g]
NJ.232A	22	36	95



IMPACT ACCESSORIES 3/8"

NJ.A - 3/8" bit holder impact sockets



NF ISO 1711-2, ISO 1711-2, DIN 3121

- NJ.236A: for 5/16 bits.
- NJ.237A: for 1/2 bits.



	A ["]	BA	GA	d ["]	d [mm]	d1 [mm]	L [mm]	Square ["]	$\Delta\Delta$ [g]
NJ.236A	5/16	BA.18B	-		22	14	37	3/8	35
NJ.237A	1/2	-	GA.18B	1/2	22	22	37	3/8	45

IMPACT SOCKETS 1/2" AND ACCESSORIES

NS.A - 1/2" drive metric 6-point impact sockets

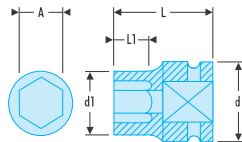

NF ISO 2725-2, NF ISO 1711-2, ISO 2725-2, ISO 1711-2, DIN 3129, ASME B107.33

- For your safety, use impact sockets and accessories with the appropriate rings and pins.

	A [mm]	BA	GA	d [mm]	d1 [mm]	L [mm]	L1 [mm]	$\Delta\Delta$ [g]
NS.8A	8	BA.20B	GA.20B	24	15	38	21	6 70
NS.9A	9	BA.20B	GA.20B	24	16	38	21	6 70
NS.10A	10	BA.20B	GA.20B	24	16	38	21	6 75
NS.11A	11	BA.20B	GA.20B	24	18	38	21	6 75
NS.12A	12	BA.20B	GA.20B	24	20	38	21	6 75
NS.13A	13	BA.20B	GA.20B	24	21	38	21	6 75
NS.14A	14	BA.20B	GA.20B	24	22	38	21	6 85
NS.15A	15	BA.20B	GA.20B	24	24	38	21	6 105
NS.16A	16	BA.20B	GA.20B	24	24	38	21	6 105
NS.17A	17	BA.20B	GA.20B	25	26	38	21	6 110
NS.18A	18	BA.20B	GA.20B	25	28	38	21	6 110
NS.19A	19	BA.20B	GA.20B	25	28	38	21	6 110
NS.20A	20	BA.20B	GA.20B	25	30	38	21	6 110
NS.21A	21	BA.20B	GA.20B	25	30	38	21	6 150
NS.22A	22	BA.25B	GA.25B	30	32	38	21	6 150
NS.23A	23	BA.25B	GA.25B	30	34	38	21	6 150
NS.24A	24	BA.25B	GA.25B	30	34	38	21	6 160
NS.26A	26	BA.25B	GA.25B	30	36	42	23	6 180
NS.27A	27	BA.25B	GA.25B	30	38	43	23	6 200
NS.28A	28	BA.25B	GA.25B	30	40	44	25	6 260
NS.29A	29	BA.25B	GA.25B	30	40	44	25	6 260
NS.30A	30	BA.25B	GA.25B	30	42	44	25	6 270
NS.32A	32	BA.25B	GA.25B	30	44	44	25	6 280

NS.A - 1/2" drive inch 6-point impact sockets

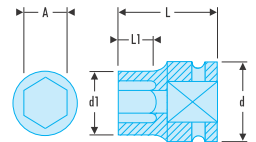

ASME B107.2

- For your safety, use impact sockets and accessories with the appropriate rings and pins.

	A ["]	BA	GA	d [mm]	d1 [mm]	L [mm]	L1 [mm]	$\Delta\Delta$ [g]
NS.3/8A	3/8	BA.20B	GA.20B	24	16,0	38	17	6 75
NS.7/16A	7/16	BA.20B	GA.20B	24	18,0	38	17	6 75
NS.1/2A	1/2	BA.20B	GA.20B	24	21,0	38	17	6 75
NS.9/16A	9/16	BA.20B	GA.20B	24	22,0	38	17	6 80
NS.5/8A	5/8	BA.25B	GA.20B	24	24,0	38	17	6 105
NS.11/16A	11/16	BA.20B	GA.20B	25	25,0	38	21	6 110
NS.3/4A	3/4	BA.25B	GA.20B	25	28,0	38	21	6 120
NS.13/16A	13/16	BA.20B	GA.20B	25	30,0	38	21	6 105
NS.7/8A	7/8	BA.25B	GA.25B	30	32,0	38	21	6 160
NS.15/16A	15/16	BA.25B	GA.25B	30	34,0	38	21	6 160
NS.1PA	1"	BA.25B	GA.25B	30	36,0	42	23	6 180
NS.1P1/16A	1" 1/16	BA.25B	GA.25B	30	38,0	43	23	6 205

■ NSD.B - 1/2" drive metric 12-point impact sockets



ED	A [mm]	d [mm]	d1 [mm]	L [mm]	L1 [mm]	12 [mm]	ΔΔ [g]
NSD.8B	8	21,9	14,5	38	3,6	12	50
NSD.9B	9	21,9	15,6	38	4,1	12	50
NSD.10B	10	21,9	16,7	38	4,6	12	53
NSD.11B	11	21,9	18	38	5,5	12	54
NSD.12B	12	21,9	19	38	6,1	12	54
NSD.13B	13	23,9	20,2	38	6,8	12	70
NSD.14B	14	23,9	21,5	38	8,4	12	70
NSD.15B	15	24,9	23,0	38	8,4	12	80
NSD.16B	16	24,9	24,9	38	9,6	12	80
NSD.18B	18	26,9	26,9	38	10,2	12	100
NSD.17B	17	25,9	25,9	38	9,6	12	90
NSD.19B	19	29,9	29,9	38	11,2	12	130
NSD.20B	20	29,9	29,9	38	11,5	12	130
NSD.21B	21	31,7	31,7	38	11,7	12	150
NSD.22B	22	31,9	31,9	38	12,5	12	150
NSD.23B	23	33,9	33,9	42	12,7	12	180
NSD.24B	24	35,9	35,9	42	13,9	12	200
NSD.26B	26	35,9	37,9	42	14,6	12	230
NSD.27B	27	38,0	39,8	46	15,8	12	270
NSD.28B	28	38,0	39,8	46	16,7	12	270
NSD.29B	29	38,0	41,9	46	16,7	12	280
NSD.30B	30	38,0	41,9	46	16,7	12	280
NSD.32B	32	38,0	43,9	46	18,3	12	280
NSD.34B	34	38,0	45,8	46	20,0	12	300
NSD.35B	35	38,0	49,8	50	20,0	12	410
NSD.36B	36	38,0	49,8	50	20,0	12	420



■ NS.LA - 1/2" drive long-reach metric 6-point impact sockets

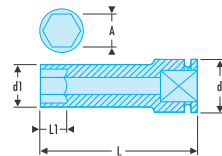

NF ISO 2725-2, NF ISO 1711-2, ISO 2725-2, ISO 1711-2, DIN 3129, ASME B107.33

- For your safety, use impact sockets and accessories with the appropriate rings and pins.

ED	A [mm]	BA	GA	d [mm]	d1 [mm]	L [mm]	L1 [mm]	6 [mm]	ΔΔ [g]
NS.8LA	8	BA.20B	GA.20B	24	15,0	78	21	6	130
NS.10LA	10	BA.20B	GA.20B	24	17,0	78	21	6	150
NS.11LA	11	BA.20B	GA.20B	24	18,0	78	21	6	160
NS.12LA	12	BA.20B	GA.20B	24	20,0	78	21	6	165
NS.13LA	13	BA.20B	GA.20B	24	21,0	78	21	6	185
NS.14LA	14	BA.20B	GA.20B	24	22,0	78	21	6	200
NS.15LA	15	BA.20B	GA.20B	24	24,0	79	21	6	210
NS.16LA	16	BA.20B	GA.20B	24	24,0	78	21	6	220
NS.17LA	17	BA.20B	GA.20B	26	26,0	78	21	6	250
NS.18LA	18	BA.20B	GA.20B	25	28,0	78	21	6	275
NS.19LA	19	BA.20B	GA.20B	25	28,0	78	21	6	270
NS.21LA	21	BA.20B	GA.20B	25	30,0	78	21	6	280
NS.22LA	22	BA.25B	GA.25B	30	32,0	78	26	6	290
NS.23LA	23	BA.25B	GA.25B	30	34,0	78	24	6	300
NS.24LA	24	BA.25B	GA.25B	30	34,0	78	24	6	300
NS.26LA	26	BA.25B	GA.25B	30	36,0	78	24	6	305
NS.27LA	27	BA.25B	GA.25B	30	38,0	78	24	6	310
NS.28LA	28	BA.25B	GA.25B	30	40,0	78	24	6	315
NS.29LA	29	BA.25B	GA.25B	30	40,0	78	24	6	330
NS.30LA	30	BA.25B	GA.25B	30	42,0	78	24	6	340
NS.32LA	32	BA.25B	GA.25B	30	44,0	78	24	6	340

■ NSB - 1/2" drive long-reach metric thin-wall 6-point impact sockets

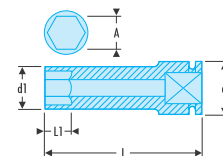

- For your safety, use impact sockets and accessories with the appropriate rings and pins.
- Thin wall for better access.
- 6-point convex pattern for increased resilience.

ED	A [mm]	BA	GA	d [mm]	d1 [mm]	L [mm]	L1 [mm]	6 [mm]	ΔΔ [g]
NSB.10	10	BA.20B	GA.20B	24	17,0	80	78	6	170
NSB.13	13	BA.20B	GA.20B	24	21,0	80	78	6	210
NSB.15	15	BA.20B	GA.20B	24	24,0	80	78	6	220
NSB.16	16	BA.20B	GA.20B	24	24,0	80	78	6	230
NSB.17	17	BA.20B	GA.20B	26	26,0	80	78	6	245
NSB.18	18	BA.20B	GA.20B	25	28,0	80	78	6	245
NSB.19	19	BA.20B	GA.20B	25	28,0	80	78	6	240
NSB.21	21	BA.20B	GA.20B	25	30,0	80	78	6	245
NSB.22	22	BA.25B	GA.25B	30	32,0	85	78	6	250
NSB.24	24	BA.25B	GA.25B	30	34,0	85	78	6	280
NSB.27	27	BA.25B	GA.25B	30	38,0	85	78	6	325
NSB.30	30	BA.25B	GA.25B	30	42,0	85	78	6	330
NSB.32	32	BA.25B	GA.25B	30	44,0	85	78	6	335



IMPACT SOCKETS 1/2" AND ACCESSORIES

SOCKETS FOR ALLOY WHEELS



NSIL.3 = set of 3 deep impact sockets with protective plastic sleeves to prevent damage to polished chrome or alloy wheels.

Protective sleeve brings 4 to 5 times superior lifetime compared to standard long socket

NSD.L - 1/2" drive metric long-reach metric 12-point impact sockets



	A [mm]	d [mm]	d1 [mm]	L [mm]	L1 [mm]	12 [mm]	ΔΔ [g]
NSD.8L	8	21.9	14.5	82	3.6	12	121
NSD.10L	10	21.9	16.7	82	4.6	12	121
NSD.11L	11	21.9	18	82	5.5	12	123
NSD.12L	12	21.9	19	82	6.1	12	124
NSD.14L	14	23.9	21.5	82	8.4	12	186
NSD.16L	16	24.9	24.9	82	9.6	12	193
NSD.17L	17	25.9	25.9	82	9.6	12	209
NSD.18L	18	26.9	26.9	82	10.2	12	221
NSD.19L	19	29.9	29.9	82	11.2	12	300
NSD.21L	21	31.7	31.7	82	11.7	12	320
NSD.22L	22	31.9	31.9	82	12.5	12	320
NSD.23L	23	33.9	33.9	82	12.7	12	350
NSD.24L	24	35.9	35.9	82	13.9	12	400
NSD.26L	26	37.9	37.9	82	14.6	12	435
NSD.27L	27	38.0	39.8	82	15.8	12	485
NSD.28L	28	38.0	39.8	82	16.7	12	455
NSD.29L	29	38.0	41.9	82	16.7	12	490
NSD.30L	30	38.0	41.9	82	16.7	12	455
NSD.32L	32	38.0	43.9	82	18.3	12	535
NSD.34L	34	38.0	45.8	90	20.0	12	540
NSD.35L	35	38.0	49.8	90	20.0	12	685
NSD.36L	36	38.0	49.8	90	20.0	12	635

NSTX Torx® 1/2" impact sockets

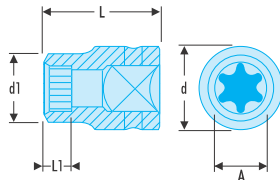

- For your safety, use impact sockets and accessories with the appropriate rings and pins.
- For Torx® male drive fasteners.

	A [mm]	BA	GA	d [mm]	d1 [mm]	L [mm]	Torx [No]	ΔΔ [g]
NSTX.10	9,19	BA.20B	GA.20B	25	14,2	38	E10	85
NSTX.12	10,95	BA.20B	GA.20B	25	15,2	38	E12	85
NSTX.14	12,67	BA.20B	GA.20B	25	18,2	38	E14	90
NSTX.16	14,70	BA.20B	GA.20B	25	19,2	38	E16	90
NSTX.18	16,38	BA.20B	GA.20B	25	22,2	38	E18	90
NSTX.20	18,16	BA.25B	GA.25B	30	24,2	38	E20	135
NSTX.24	21,84	BA.25B	GA.25B	30	28,2	40	E24	140

NSTX.L - Torx® 1/2" female impact sockets

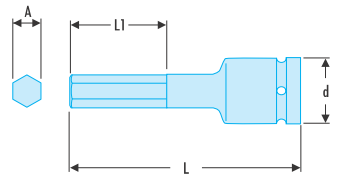

- For your safety, use impact sockets and accessories with the appropriate rings and pins.
- For Torx® male drive fasteners.

	A [mm]	BA	GA	d [mm]	L [mm]	L1 [mm]	Torx [No]	ΔΔ [g]
NSTX.10L	9,37	BA.20B	GA.20B	25	70	7,11	E10	95
NSTX.12L	11,12	BA.20B	GA.20B	25	70	8,25	E12	100
NSTX.14L	12,85	BA.20B	GA.20B	25	70	9,52	E14	105
NSTX.16L	14,71	BA.20B	GA.20B	25	70	10,79	E16	120
NSTX.18L	16,64	BA.20B	GA.20B	25	70	11,94	E18	140
NSTX.20L	18,41	BA.20B	GA.20B	25	70	13,33	E20	150
NSTX.22L	20,24	BA.20B	GA.20B	25	70	14,48	E22	160
NSTX.24L	22,09	BA.20B	GA.20B	25	70	15,00	E24	170

■ NSX.B 1/2" drive impact bits for Torx® heads

- For your safety, use impact sockets and accessories with the appropriate rings and pins.
- For Torx® male drive fasteners.

➤	A [mm]	BA	GA	d [mm]	L [mm]	L1 [mm]	Torx [No]	ΔΔ [g]
NSX.30B	5,58	BA.20B	GA.20B	25	55	15	T30	90
NSX.40B	6,67	BA.20B	GA.20B	25	55	15	T40	95
NSX.45B	7,85	BA.20B	GA.20B	25	55	15	T45	95
NSX.50B	8,89	BA.20B	GA.20B	25	55	15	T50	100
NSX.55B	11,28	BA.20B	GA.20B	25	55	15	T55	105
NSX.60B	13,36	BA.20B	GA.20B	25	55	15	T60	110

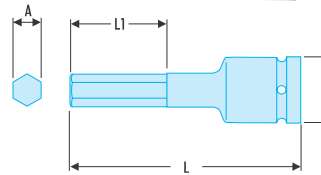

■ NSX.L - Torx® 1/2" male impact sockets

- For your safety, use impact sockets and accessories with the appropriate rings and pins.
- For Torx® female drive fasteners.
- Monobloc driver socket.

➤	A [mm]	BA	GA	d [mm]	L [mm]	L1 [mm]	Torx [No]	ΔΔ [g]
NSX.20L	3,84	BA.20B	GA.20B	25	78	15	T20	80
NSX.25L	4,4	BA.20B	GA.20B	25	78	15	T25	80
NSX.30L	5,49	BA.20B	GA.20B	25	78	15	T30	80
NSX.40L	6,6	BA.20B	GA.20B	25	78	15	T40	80
NSX.45L	7,77	BA.20B	GA.20B	25	78	15	T45	85
NSX.50L	8,79	BA.20B	GA.20B	25	78	15	T50	90
NSX.55L	11,17	BA.20B	GA.20B	25	78	15	T55	105
NSX.60L	13,2	BA.20B	GA.20B	25	78	15	T60	120
NSX.70L	15,49	BA.20B	GA.20B	25	78	15	T70	135

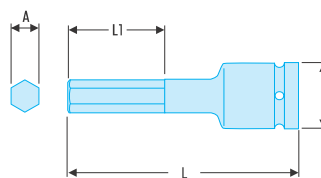

■ NSHM 1/2" drive metric impact bits for hexagon socket heads

- For your safety, use impact sockets and accessories with the appropriate rings and pins.
- Monobloc driver socket.

➤	A [mm]	BA	GA	d [mm]	L [mm]	L1 [mm]	6 [mm]	ΔΔ [g]
NSHM.5	5	BA.20B	GA.20B	25	79	16	6	70
NSHM.6	6	BA.20B	GA.20B	25	79	16	6	70
NSHM.8	8	BA.20B	GA.20B	25	79	25	6	90
NSHM.10	10	BA.20B	GA.20B	25	79	27	6	110
NSHM.12	12	BA.20B	GA.20B	25	79	27	6	130
NSHM.14	14	BA.20B	GA.20B	25	79	27	6	130
NSHM.17	17	BA.20B	GA.20B	25	79	27	6	170
NSHM.19	19	BA.20B	GA.20B	25	79	27	6	190

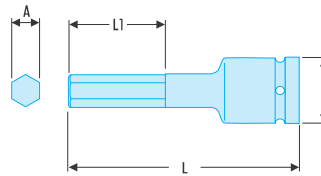

■ NSV - XZN® 1/2" male impact sockets

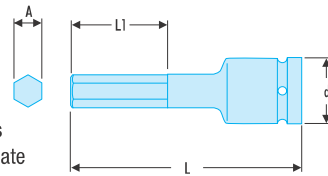

- For your safety, use impact sockets and accessories with the appropriate rings and pins.
- For XZN® female drive fasteners.

➤	A [mm]	BA	GA	d [mm]	L [mm]	L1 [mm]	XZN [No]	ΔΔ [g]
NSV.6	5,97	BA.20B	GA.20B	25	50	1515	6	60
NSV.8	7,16	BA.20B	GA.20B	25	50	15	8	65
NSV.10	9,56	BA.20B	GA.20B	25	50	15	10	70
NSV.12	11,36	BA.20B	GA.20B	25	50	15	12	75
NSV.14	13,17	BA.20B	GA.20B	25	50	15	14	80
NSV.16	15,58	BA.20B	GA.20B	25	50	15	16	90
NSV.18	16,79	BA.20B	GA.20B	25	50	15	18	95

■ NSV.L - XZN® 1/2" male long-reach impact sockets

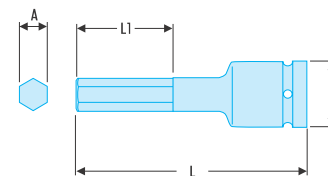

- For your safety, use impact sockets and accessories with the appropriate rings and pins.
- For XZN® female drive fasteners.

➤	A [mm]	BA	GA	d [mm]	L [mm]	L1 [mm]	XZN [No]	ΔΔ [g]
NSV.10L	9,56	BA.20B	GA.20B	25	78	1515	10	95
NSV.12L	11,36	BA.20B	GA.20B	25	78	15	12	105
NSV.14L	13,17	BA.20B	GA.20B	25	78	15	14	120
NSV.16L	15,58	BA.20B	GA.20B	25	78	1515	16	140
NSV.18L	16,79	BA.20B	GA.20B	25	78	1515	18	150

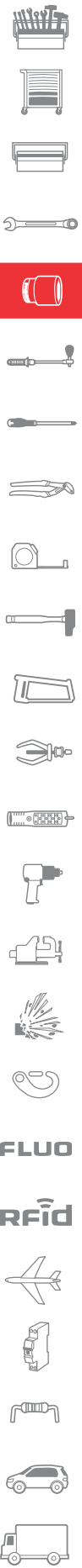

IMPACT SOCKETS 1/2" AND ACCESSORIES

■ NS.A - 1/2" drive impact extensions

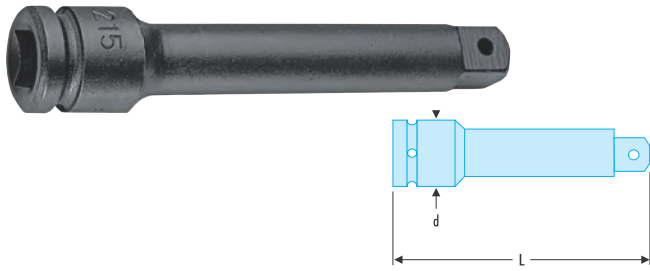

ASME B107.2

- For your safety, use impact extensions and accessories with the appropriate rings and pins.



🔗	BA	GA	d [mm]	L [mm]	ΔΔ [g]
NS.210A	BA.20B	GA.20B	24	7575	130
NS.215A	BA.20B	GA.20B	24	125	230
NS.219A	BA.20B	GA.20B	24	250	510

■ 1/2" drive impact universal joint

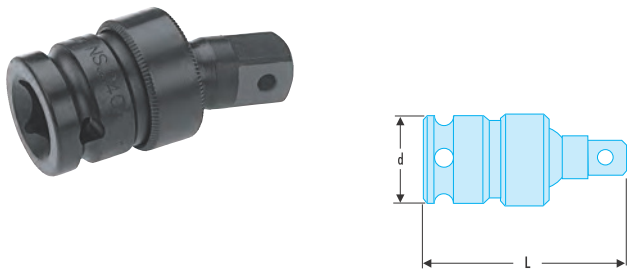

ASME B107.2

- For your safety, use impact universal joints with the appropriate rings and pins.



🔗	BA	GA	d [mm]	L [mm]	ΔΔ [g]
NS.240A	BA.22B	GA.22B	28	60	205

■ 1/2" to 3/8" impact coupler

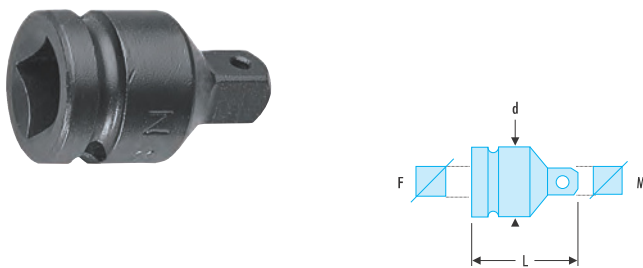

ASME B107.2

- For your safety, use impact sockets and accessories with the appropriate rings and pins.



🔗	BA	GA	d [mm]	L [mm]	Square ["]	ΔΔ [g]
NS.230A	BA.20B	GA.20B	24	35	F = 1/2" - M = 3/8"	35

■ 1/2" to 3/4" impact coupler



ASME B107.2

- For your safety, use impact couplers with the appropriate rings and pins.



🔗	BA	GA	d [mm]	L [mm]	Square ["]	ΔΔ [g]
NS.232B	BA.25B	GA.25B	30	48	F = 1/2" - M = 3/4"	170

■ NS.A - 1/2" impact bit holder sockets

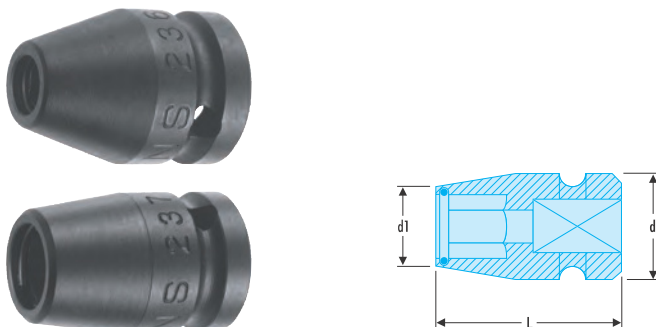

NF ISO 1711-2, ISO 1711-2, DIN 3121

- For 1/2" bits.
- NS.236: for 5/16" bits.
- NS.237: for 1/2" bits.



🔗	A ["]	BA	GA	d ["]	d [mm]	d1 [mm]	L [mm]	Square ["]	ΔΔ [g]
NS.236A	5/16				24	15,5	40	1/2	60
NS.237A	1/2			1/2	24	20	40	1/2	40

IMPACT RANGE

IMPACT SOCKETS 3/4" AND ACCESSORIES

Set of 3/4" impact sockets 19 to 42 mm

- For your safety, use impact sockets and accessories with the appropriate rings and pins.
- Comprising:
 - 16 x Sockets: NK.19A - 21 - 22 - 23 - 24 - 26 - 27 - 28 - 29 - 30 - 32 - 34 - 36 - 38 - 41 - 42 mm.
 - 2 x Accessories: NK.210A and NK.240A.
 - 1 x Rings: BA.36B and 1 x Pins: GA.35B.
 - Metal case BT.111, dim. (L. x D. x H.): 396 x 224 x 82 mm.
 - Tray PL.79A.



FACOM	H [mm]	L [mm]	ΔΔ [kg]
NK.500E	82	396	11

IMPACT SOCKETS 3/4" AND ACCESSORIES

16-piece set of 3/4" impact sockets 19 to 42 mm

- For your safety, use impact sockets with suitable rings and pins.
- 16 3/4" sockets: 19-21-22-23-24-26-27-28-29-30-32-34-36- 38-41-42 mm.
- NK.210A - 175 mm extension
- Universal joint NK.240A.
- BA.36B (x1) ring and GA.35B associated pin
- Square drive bit 3/4".
- Set BT.111.
- Tray PL.79A.



FACOM	ΔΔ [kg]
NK0.500	11

Set of 3/4" impact sockets size 3/4" to 1"5/8

- For your safety, use impact sockets and accessories with the appropriate rings and pins.
- Comprising:
 - 12 x Sockets: NK. 3/4'A - 13/16' - 7/8'
 - 15/16' - 1' - 1'1/16 - 1'1/8 - 1'1/4 - 1'5/16 - 1'7/16 - 1'1/2 - 1'5/8.
 - 1 x Pin: GA.37A and 1 x Ring: BA.38A.
 - 2 x Accessories: NK.210A and NK.240A.
 - Metal case BT.111, dim.(L. x D. x H.): 396 x 224 x 82 mm.
 - Tray PL.80A.



FACOM	H [mm]	L [mm]	ΔΔ [kg]
NK.500U	82	396	8.9



FLUO

RFid



IMPACT SOCKETS 3/4" AND ACCESSORIES

■ NK.A - 3/4" drive metric 6-point impact sockets

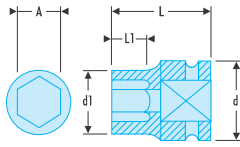

• For your safety, use impact sockets and accessories with the appropriate rings and pins.



Socket	A [mm]	BA	GA	d [mm]	d1 [mm]	L [mm]	L1 [mm]	⊕ [mm]	ΔΔ [g]
NK.17A	17	BA.30B	GA.31B	38	28,5	50	14	6	300
NK.18A	18	BA.30B	GA.31B	38	29,0	50	14	6	310
NK.19A	19	BA.30B	GA.31B	38	29,5	50	14	6	315
NK.21A	21	BA.30B	GA.31B	38	32,0	50	14	6	330
NK.22A	22	BA.30B	GA.31B	38	34,0	50	14	6	345
NK.23A	23	BA.30B	GA.31B	38	35,0	50	17	6	350
NK.24A	24	BA.30B	GA.31B	38	36,0	50	17	6	350
NK.26A	26	BA.30B	GA.31B	38	38,0	52	18	6	480
NK.27A	27	BA.30B	GA.31B	38	42,0	52	18	6	480
NK.28A	28	BA.30B	GA.31B	38	42,0	52	18	6	520
NK.29A	29	BA.30B	GA.31B	38	42,0	52	18	6	520
NK.30A	30	BA.30B	GA.31B	38	42,0	52	20	6	545
NK.32A	32	BA.30B	GA.31B	38	46,0	55	22	6	620
NK.33A	33	BA.30B	GA.31B	44	48,0	57	22	6	650
NK.34A	34	BA.30B	GA.31B	44	48,0	57	22	6	680
NK.35A	35	BA.30B	GA.31B	44	50,0	57	24	6	680
NK.36A	36	BA.30B	GA.31B	44	52,0	57	24	6	705
NK.38A	38	BA.30B	GA.31B	44	56,0	57	26	6	890
NK.41A	41	BA.30B	GA.31B	44	58,0	63	27	6	890
NK.42A	42	BA.30B	GA.31B	44	62,0	63	27	6	925
NK.46A	46	BA.30B	GA.31B	44	65,0	68	30	6	1000

■ NK.A - 3/4" drive inch 6-point impact sockets

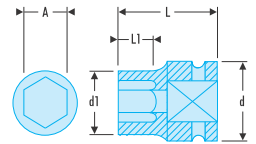

• For your safety, use impact sockets and accessories with the appropriate rings and pins.

Socket	A ["]	BA	GA	d [mm]	d1 [mm]	L [mm]	L1 [mm]	⊕ [mm]	ΔΔ [g]
NK.3/4A	3/4	BA.30B	GA.31B	38	29,5	50	14	6	315
NK.13/16A	13/16	BA.30B	GA.31B	38	32,0	50	14	6	330
NK.7/8A	7/8	BA.30B	GA.31B	38	34,0	50	14	6	345
NK.15/16A	15/16	BA.30B	GA.31B	38	36,0	50	17	6	350
NK.1PA	1"	BA.30B	GA.31B	44	41	50	18	6	480
NK.1P/16A	1" 1/16	BA.30B	GA.31B	44	43	54	23	6	480
NK.1P/8A	1" 1/8	BA.30B	GA.31B	44	44	54	23	6	520
NK.1P1/4A	1" 1/4	BA.30B	GA.31B	44	49	56	23	6	620
NK.1P5/16A	1" 5/16	BA.30B	GA.31B	44	53	56	23	6	680
NK.1P7/16A	1" 7/16	BA.30B	GA.31B	44	55	56	24	6	515
NK.1P1/2A	1" 1/2	BA.30B	GA.31B	44	57	58	26	6	890
NK.1P5/8A	1" 5/8	BA.30B	GA.31B	44	60	58	28	6	890

■ NK.LA - 3/4" drive metric long-reach metric 6-point impact sockets

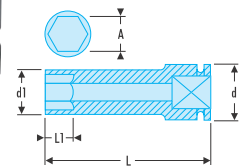

• For your safety, use impact sockets and accessories with the appropriate rings and pins.

Socket	A [mm]	BA	GA	d [mm]	d1 [mm]	L [mm]	L1 [mm]	⊕ [mm]	ΔΔ [g]
NK.17LA	17	BA.30B	GA.31B	44	31	90	20	6	550
NK.19LA	19	BA.30B	GA.31B	44	33	90	24	6	620
NK.21LA	21	BA.30B	GA.31B	44	35	90	24	6	600
NK.22LA	22	BA.30B	GA.31B	44	37	90	24	6	780
NK.23LA	23	BA.30B	GA.31B	44	38	90	24	6	780
NK.24LA	24	BA.30B	GA.31B	44	39	90	40	6	820
NK.26LA	26	BA.30B	GA.31B	44	41	90	40	6	800
NK.27LA	27	BA.30B	GA.31B	44	43	90	40	6	810
NK.29LA	29	BA.30B	GA.31B	44	45	90	40	6	890
NK.30LA	30	BA.30B	GA.31B	44	47	90	40	6	900
NK.32LA	32	BA.30B	GA.31B	44	48	90	45	6	930
NK.33LA	33	BA.30B	GA.31B	44	48	90	45	6	980
NK.34LA	34	BA.30B	GA.31B	44	48	90	45	6	1100
NK.35LA	35	BA.30B	GA.31B	44	50	90	45	6	1240
NK.36LA	36	BA.30B	GA.31B	44	52	90	45	6	1240
NK.38LA	38	BA.30B	GA.31B	44	56	90	45	6	1220
NK.41LA	41	BA.30B	GA.31B	44	58	90	48	6	1470
NK.42LA	42	BA.30B	GA.31B	44	62	90	48	6	1450
NK.46LA	46	BA.30B	GA.31B	44	65	100	48	6	1500

■ NKD.A - 3/4" drive metric 12-point impact sockets

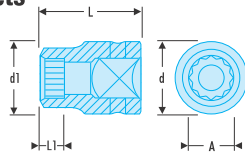

• For your safety, use impact sockets and accessories with the appropriate rings and pins.

Socket	A [mm]	BA	GA	d [mm]	d1 [mm]	L [mm]	L1 [mm]	⊕ [mm]	ΔΔ [g]
NKD.16A	16	BA.30B	GA.31B	38	38	50	14	12	185
NKD.17A	17	BA.30B	GA.31B	38	30,0	50	14	12	190
NKD.18A	18	BA.30B	GA.31B	38	38	50	14	12	215
NKD.19A	19	BA.30B	GA.31B	38	32,5	50	14	12	220
NKD.21A	22	BA.30B	GA.31B	38	36,5	50	14	12	230
NKD.22A	21	BA.30B	GA.31B	38	50	50	14	12	230
NKD.23A	23	BA.30B	GA.31B	39,9	50	50	12,7	12	248
NKD.24A	24	BA.30B	GA.31B	39,9	50	50	13,9	12	249
NKD.26A	26	BA.30B	GA.31B	40,9	50	50	14,6	12	297
NKD.27A	27	BA.30B	GA.31B	40,9	50	50	15,8	12	297
NKD.28A	28	BA.30B	GA.31B	43,9	50	50	16,3	12	330
NKD.29A	29	BA.30B	GA.31B	44	50	50	16,7	12	410
NKD.30A	30	BA.30B	GA.31B	44	50	50	16,7	12	410
NKD.32A	32	BA.30B	GA.31B	44	50	50	18,3	12	410
NKD.33A	33	BA.30B	GA.31B	44	56	56	19,1	12	500
NKD.34A	34	BA.30B	GA.31B	44	56	56	20,0	12	500
NKD.35A	35	BA.30B	GA.31B	44	56	56	20,1	12	520
NKD.36A	36	BA.30B	GA.31B	44	56	56	21,5	12	540
NKD.38A	38	BA.30B	GA.31B	44	56	56	22,3	12	540
NKD.41A	41	BA.30B	GA.31B	45	62	62	24,9	12	618
NKD.42A	42	BA.30B	GA.31B	45	62	62	25,4	12	679
NKD.46A	46	BA.30B	GA.31B	45	63	63	28,6	12	814

■ **NKB - 3/4" drive long-reach metric thin-wall 6-point impact sockets**

- For your safety, use impact sockets and accessories with the appropriate rings and pins.
- Thin wall for better access.
- 6-point convex pattern for increased resilience.

🔗	A [mm]	BA	GA	d [mm]	d1 [mm]	L [mm]	L1 [mm]	6 [mm]	ΔΔ [g]
NKB.21	21	BA.36B	GA.35B	44	35	90	24	6	600
NKB.22	22	BA.36B	GA.35B	44	37	90	24	6	600
NKB.24	24	BA.36B	GA.35B	44	39	90	40	6	640
NKB.27	27	BA.36B	GA.35B	44	43	90	40	6	670
NKB.30	30	BA.36B	GA.35B	44	47	90	40	6	700
NKB.32	32	BA.36B	GA.35B	44	48	90	65	6	706
NKB.33	33	BA.36B	GA.35B	44	48	90	45	6	750
NKB.36	36	BA.36B	GA.35B	44	52	90	45	6	765

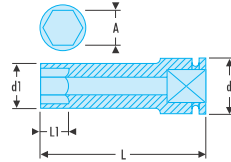

■ **NKD.L - 3/4" drive metric long-reach metric 12-point impact sockets**

- For your safety, use impact sockets and accessories with the appropriate rings and pins.

🔗	A [mm]	BA	GA	d [mm]	d1 [mm]	L [mm]	L1 [mm]	12 [mm]	ΔΔ [g]
NKD.17L	17	BA.30B	GA.31B	40	28,6	85	9,3	12	450
NKD.19L	19	BA.30B	GA.31B	30,5	30	85	11,1	12	450
NKD.21L	21	BA.30B	GA.31B	40	34,5	85	11,7	12	450
NKD.22L	22	BA.30B	GA.31B	40	35,0	85	12,5	12	470
NKD.23L	23	BA.30B	GA.31B	40	38,0	85	12,7	12	490
NKD.24L	24	BA.30B	GA.31B	40	38,0	85	13,9	12	490
NKD.26L	26	BA.30B	GA.31B	40	40,9	85	14,6	12	500
NKD.27L	27	BA.30B	GA.31B	40	40,9	85	15,8	12	500
NKD.29L	29	BA.30B	GA.31B	44	43,9	85	16,7	12	570
NKD.30L	30	BA.30B	GA.31B	44	45,7	85	16,7	12	640
NKD.32L	32	BA.30B	GA.31B	44	48,0	85	18,3	12	640
NKD.33L	33	BA.30B	GA.31B	44	50,7	85	19,1	12	750
NKD.34L	34	BA.30B	GA.31B	44	50,7	85	20,0	12	750
NKD.35L	35	BA.30B	GA.31B	44	51,7	85	20,1	12	750
NKD.36L	36	BA.30B	GA.31B	44	53,7	85	21,5	12	780
NKD.38L	38	BA.30B	GA.31B	44	53,7	85	22,3	12	820
NKD.41L	41	BA.30B	GA.31B	45	60,0	85	24,9	12	910
NKD.42L	42	BA.30B	GA.31B	45	62,0	85	25,4	12	950
NKD.46L	46	BA.30B	GA.31B	45	67,0	85	28,6	12	1260

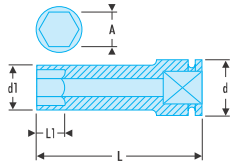

■ **NKHM - 3/4" drive metric impact bits for hexagon socket head**

- For your safety, use impact sockets and accessories with the appropriate rings and pins.
- Non-removable bits.

🔗	A [mm]	BA	GA	d [mm]	L [mm]	L1 [mm]	6 [mm]	ΔΔ [g]
NKHM.17	17	BA.36B	GA.35B	44	100	21	6	600
NKHM.19	19	BA.36B	GA.35B	44	100	21	6	600
NKHM.22	22	BA.36B	GA.35B	44	100	21	6	600
NKHM.24	24	BA.36B	GA.35B	44	100	21	6	600

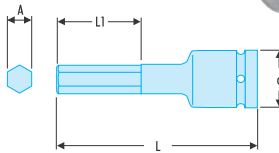

■ **NKTX.L - Torx® 3/4" female impact sockets**

- For your safety, use impact sockets and accessories with the appropriate rings and pins.
- For Torx® male drive fasteners.

🔗	A [mm]	BA	GA	d [mm]	d1 [mm]	L [mm]	L1 [mm]	Torx [No]	ΔΔ [g]
NKTX.18L	16.64	BA.36B	GA.35B	44	21,5	100	11,94	E18	440
NKTX.20L	18.41	BA.36B	GA.35B	44	23,5	100	13,33	E20	455
NKTX.22L	20.24	BA.36B	GA.35B	44		100	14,48	E22	460
NKTX.24L	22.09	BA.36B	GA.35B	44	28,0	100	15,00	E24	480

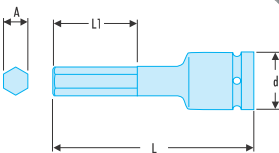

IMPACT SOCKETS 3/4" AND ACCESSORIES

NKVR - XZN® 3/4" Tamper impact sockets



• For your safety, use impact sockets and accessories with the appropriate rings and pins.

	A [mm]	BA	GA	d [mm]	L [mm]	L1 [mm]	XZN [No]	ΔΔ [g]
NKVR.16	16	BA.36B	GA.35B	44	50	19	16	220
NKVR.18	18	BA.36B	GA.35B	44	50	19	18	225

NKXR - Torx® 3/4" Tamper impact sockets



• For your safety, use impact sockets and accessories with the appropriate rings and pins.

	A [mm]	BA	GA	d [mm]	L [mm]	L1 [mm]	Torx [No]	ΔΔ [g]
NKXR.70	15.49	BA.36B	GA.35B	44	50	16	70	230
NKXR.80	17.51	BA.36B	GA.35B	44	50	16	80	230
NKXR.90	19.88	BA.36B	GA.35B	44	50	16	90	240
NKXR.100	22.09	BA.36B	GA.35B	44	50	16	100	255

NK.A - 3/4" drive impact extensions

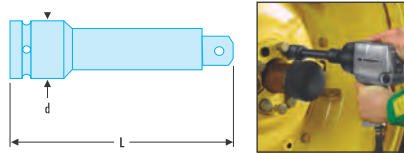

ASME B107.2

• For your safety, use impact extensions and accessories with the appropriate rings and pins.

	BA	GA	d [mm]	L [mm]	ΔΔ [g]
NK.210A	BA.30B	GA.31B	38	175	105
NK.215A	BA.30B	GA.31B	38	252	120
NK.218A	BA.30B	GA.31B	38	330	150

3/4" drive impact universal joint

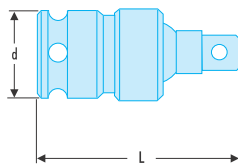

ASME B107.2

• For your safety, use impact universal joints with the appropriate rings and pins.

	BA	GA	d [mm]	L [mm]	ΔΔ [g]
NK.240A	BA.36B	GA.35B	44	90	720

3/4" to 1/2" impact coupler

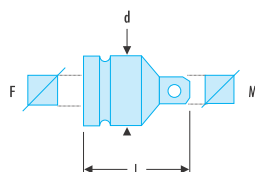

ASME B107.2

• For your safety, use impact couplers with the appropriate rings and pins.

	BA	GA	d [mm]	L [mm]	Square ["]	ΔΔ [g]
NK.230A	BA.36B	GA.35B	44	54	F = 3/4" - M = 1/2"	210

3/4" to 1" impact coupler

For your safety, use impact sockets and accessories with the appropriate rings and pins.

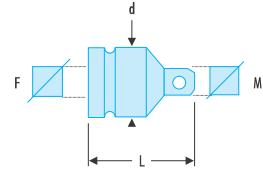

	BA	GA	d [mm]	L [mm]	Square ["]	$\Delta\Delta$ [g]
NK.232A	BA.36B	GA.35B	44	68	F = 3/4" - M = 1"	375

IMPACT SOCKETS 1" AND ACCESSORIES

NM.A - 1" drive metric 6-point impact sockets

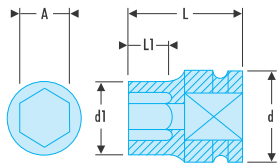

NF ISO 2725-2, NF ISO 1711-2, ISO 2725-2, ISO 1711-2, DIN 3129, ASME B107.33

For your safety, use impact sockets and accessories with the appropriate rings and pins.

	A [mm]	BA	GA	d [mm]	d1 [mm]	L [mm]	L1 [mm]	Φ [mm]	$\Delta\Delta$ [kg]
NM.22A	22	BA.45B	GA.45B	54	40	60	17	6	0,500
NM.24A	24	BA.45B	GA.45B	54	42	60	18	6	0,500
NM.26A	26	BA.45B	GA.45B	54	42	60	18	6	0,520
NM.27A	27	BA.45B	GA.45B	54	44	60	18	6	0,520
NM.28A	28	BA.45B	GA.45B	54	44	60	18	6	0,520
NM.29A	29	BA.45B	GA.45B	54	46	60	18	6	0,520
NM.30A	30	BA.45B	GA.45B	54	48	63	20	6	0,750
NM.32A	32	BA.45B	GA.45B	54	50	63	22	6	0,760
NM.33A	33	BA.45B	GA.45B	54	52	63	22	6	0,750
NM.34A	34	BA.45B	GA.45B	54	52	63	22	6	0,750
NM.35A	35	BA.45B	GA.45B	54	54	63	24	6	0,800
NM.36A	36	BA.45B	GA.45B	54	56	65	24	6	0,840
NM.38A	38	BA.45B	GA.45B	54	58	65	26	6	0,840
NM.41A	41	BA.45B	GA.45B	54	63	70	27	6	1,040
NM.42A	42	BA.45B	GA.45B	54	66	70	30	6	1,040
NM.46A	46	BA.45B	GA.45B	54	68	70	30	6	1,500
NM.50A	50	BA.45B	GA.45B	54	73	75	33	6	1,650
NM.52A	52	BA.45B	GA.45B	54	75	80	36	6	1,750
NM.54A	54	BA.45B	GA.45B	54	78	80	36	6	1,790
NM.55A	55	BA.45B	GA.45B	54	80	80	36	6	1,840
NM.56A	56	BA.45B	GA.45B	54	83	82	39	6	2,060
NM.58A	58	BA.45B	GA.45B	54	85	82	39	6	2,190
NM.60A	60	BA.45B	GA.45B	54	87	82	39	6	2,370
NM.65A	65	BA.45B	GA.45B	54	93	87	45	6	2,730
NM.70A	70	BA.45B	GA.45B	54	99	94	45	6	2,980
NM.75A	75	BA.76B	GA.77B	86	106	100	48	6	3,300
NM.77A	77	BA.76B	GA.77B	86	108	100	52	6	3,500

NM.LA - 1" drive long-reach metric 6-point impact sockets

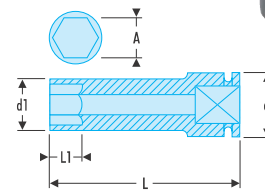

NF ISO 2725-2, NF ISO 1711-2, ISO 2725-2, ISO 1711-2, DIN 3129, ASME B107.33

For your safety, use impact sockets and accessories with the appropriate rings and pins.

	A [mm]	BA	GA	d [mm]	d1 [mm]	L [mm]	L1 [mm]	Φ [mm]	$\Delta\Delta$ [kg]
NM.22LA	22	BA.45B	GA.45B	54	40	100	17	6	1,0
NM.24LA	24	BA.45B	GA.45B	54	42	100	18	6	1,0
NM.27LA	27	BA.45B	GA.45B	54	46	100	18	6	1,1
NM.29LA	29	BA.45B	GA.45B	54	49	100	18	6	1,2
NM.30LA	30	BA.45B	GA.45B	54	50	100	20	6	1,2
NM.32LA	32	BA.45B	GA.45B	54	50	100	22	6	1,3
NM.33LA	33	BA.45B	GA.45B	54	52	100	22	6	1,3
NM.34LA	34	BA.45B	GA.45B	54	52	100	22	6	1,3
NM.35LA	35	BA.45B	GA.45B	54	54	100	24	6	1,3
NM.36LA	36	BA.45B	GA.45B	54	56	100	24	6	1,5
NM.38LA	38	BA.45B	GA.45B	54	58	100	26	6	1,5
NM.41LA	41	BA.45B	GA.45B	54	63	100	27	6	1,7
NM.42LA	42	BA.45B	GA.45B	54	64	100	27	6	1,7
NM.46LA	46	BA.45B	GA.45B	54	68	100	30	6	1,6
NM.50LA	50	BA.45B	GA.45B	54	73	100	33	6	1,9
NM.54LA	54	BA.45B	GA.45B	54	78	100	36	6	1,8
NM.55LA	55	BA.45B	GA.45B	54	80	100	36	6	1,9
NM.60LA	60	BA.45B	GA.45B	54	87	120	39	6	2,2
NM.65LA	65	BA.45B	GA.45B	54	93	120	45	6	2,2
NM.70LA	70	BA.45B	GA.45B	54	99	125	45	6	2,2

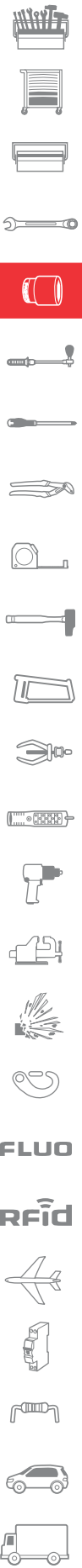

IMPACT SOCKETS 1" AND ACCESSORIES

■ NMB - Long-reach 6-point thin-wall sockets



NF ISO 2725-2, NF ISO 1711-2, ISO 2725-2, ISO 1711-2, DIN 3129, ASME B107.33

- Thin wall for better access.
- For your safety, use impact sockets and accessories with the appropriate rings and pins.
- 6-point convex pattern for increased resilience.

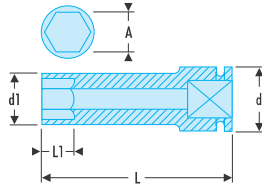

Socket	A [mm]	BA	GA	d [mm]	d1 [mm]	L [mm]	L1 [mm]	6 [mm]	ΔΔ [kg]
NMB.24	24	BA.45B	GA.45B	54	42	100	18	6	0.940
NMB.27	27	BA.45B	GA.45B	54	46	100	18	6	1.0
NMB.30	30	BA.45B	GA.45B	54	50	100	20	6	1.0
NMB.32	32	BA.45B	GA.45B	54	50	100	22	6	1.0
NMB.33	33	BA.45B	GA.45B	54	52	100	22	6	1.0
NMB.36	36	BA.45B	GA.45B	54	56	100	24	6	1.1
NMB.46	46	BA.45B	GA.45B	54	68	100	30	6	1.5
NMB.50	50	BA.45B	GA.45B	54	73	100	33	6	1.5

■ NM.ELA - 1" drive extra-long reach metric 6-point impact sockets



- For your safety, use impact extensions and accessories with the appropriate rings and pins.

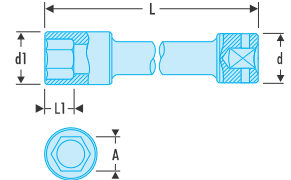

Socket	A [mm]	BA	GA	d [mm]	d1 [mm]	L [mm]	L1 [mm]	6 [mm]	ΔΔ [kg]
NM.32ELA	32	BA.45B	GA.45B	54	52	270	32	6	2.6
NM.33ELA	33	BA.454B	GA.45B	54	53	270	33.0	6	2.6

■ 12-point 1" impact socket



- Dimensions 65 mm.
- Special hubs.

Socket	A [mm]	d [mm]	d1 [mm]	L [mm]	L1 [mm]	12 [mm]	ΔΔ [g]
NMD.65A	65	62	93	80	35	12	1.850

■ NM.A - 1" drive impact extensions



ASME B107.2

- For your safety, use impact couplers with the appropriate rings and pins.



Extension	BA	GA	d [mm]	L [mm]	ΔΔ [kg]
NM.209A	BA.45B	GA.45B	54	125	1.2
NM.210A	BA.45B	GA.45B	54	200	1.6
NM.215A	BA.45B	GA.45B	54	330	2.5

■ 1" drive impact universal joint



ASME B107.2

- For your safety, use impact couplers with the appropriate rings and pins.

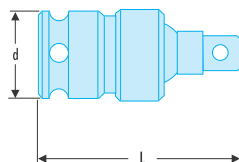

Socket	BA	GA	d [mm]	L [mm]	ΔΔ [kg]
NM.240A	BA.45B	GA.45B	54	110	2.0

■ NM.A - 1" to 3/4" impact couplers



ASME B107.2

- For your safety, use impact couplers with the appropriate rings and pins.

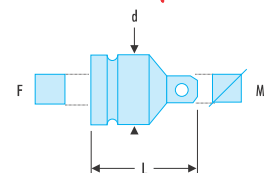

Socket	BA	GA	d [mm]	L [mm]	Square ["]	ΔΔ [kg]
NM.230A	BA.45B	GA.45B	54	75	F = 1" - M = 3/4"	0.540
NM.231A	BA.45B	GA.45B	54	154	F = 1" - M = 3/4"	1.0

1" to 1/2" impact coupler



ASME B107.2

For your safety, use impact couplers with the appropriate rings and pins.

Part No.	BA	GA	d [mm]	d1 [mm]	ΔΔ [kg]
NM.232A	BA.45B	GA.45B	54	90	1.50

NG.A - 1 1/2" drive impact extensions



ASME B107.2

For your safety, use impact extensions and accessories with the appropriate rings and pins.

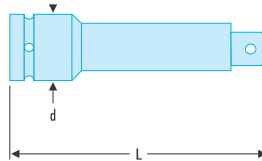

Part No.	BA	GA	d [mm]	L [mm]	ΔΔ [kg]
NG.210A	BA.74B	GA.75B	86	250	5.6

1 1/2" to 1" impact coupler

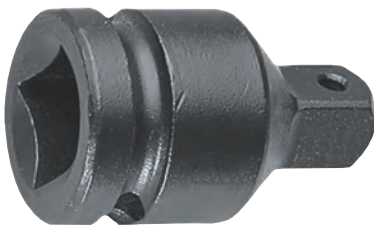

ASME B107.2

For your safety, use impact universal joints with the appropriate rings and pins.

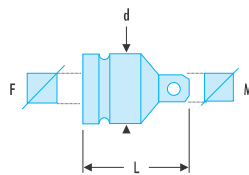

Part No.	BA	GA	d [mm]	L [mm]	Square ["]	ΔΔ [kg]
NG.230A	BA.74B	GA.75B	86	98	F = 1" 1/2 - M = 1"	2.2

IMPACT SOCKETS 1" 1/2 AND ACCESSORIES

NG.A - 1 1/2" drive metric 6-point impact sockets



NF ISO 2725-2,
NF ISO 1711-2,
ISO 2725-2, ISO 1711-2,
DIN 3129, ASME B107.33

For your safety, use impact sockets and accessories with the appropriate rings and pins.

Part No.	A [mm]	BA	GA	d [mm]	d1 [mm]	L [mm]	L1 [mm]	6 [mm]	ΔΔ [kg]
NG.55A	55	BA.74B	GA.75B	86	87	90	38	6	2.5
NG.60A	60	BA.74B	GA.75B	86	94	92	38	6	2.9
NG.65A	65	BA.74B	GA.75B	86	100	95	40	6	3.2
NG.70A	70	BA.74B	GA.75B	86	106	100	43	6	3.8
NG.75A	75	BA.74B	GA.75B	86	112	103	45	6	3.9
NG.80A	80	BA.74B	GA.75B	86	119	110	51	6	4.6
NG.85A	85	BA.74B	GA.75B	86	125	118	52	6	5.4
NG.90A	90	BA.74B	GA.75B	86	131	118	52	6	5.7
NG.95A	95	BA.74B	GA.75B	95	137	118	52	6	6.6
NG.100A	100	BA.74B	GA.75B	95	144	125	59	6	7.2
NG.105A	105	BA.74B	GA.75B	95	150	125	59	6	7.8
NG.110A	110	BA.74B	GA.75B	95	156	125	59	6	8.6
NG.115A	115	BA.74B	GA.75B	95	162	135	67	6	9.7
NG.120A	120	BA.74B	GA.75B	95	169	135	67	6	9.5

1 1/2" impact universal joint



ASME B107.2

For your safety, use impact universal joints with the appropriate rings and pins.

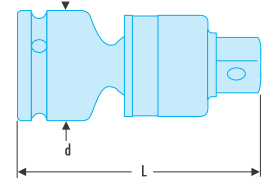

Part No.	BA	GA	d [mm]	L [mm]	ΔΔ [kg]
NG.240A	BA.74B	GA.75B	86	172	4.2

1 1/2" to 2 1/2" impact coupler



ASME B107.2

For your safety, use impact universal joints with the appropriate rings and pins.

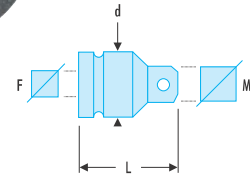

Part No.	BA	GA	d [mm]	L [mm]	Square ["]	ΔΔ [kg]
NG.232A	BA.74B	GA.75B	86	120	F = 1" 1/2 - M = 2" 1/2	3.9



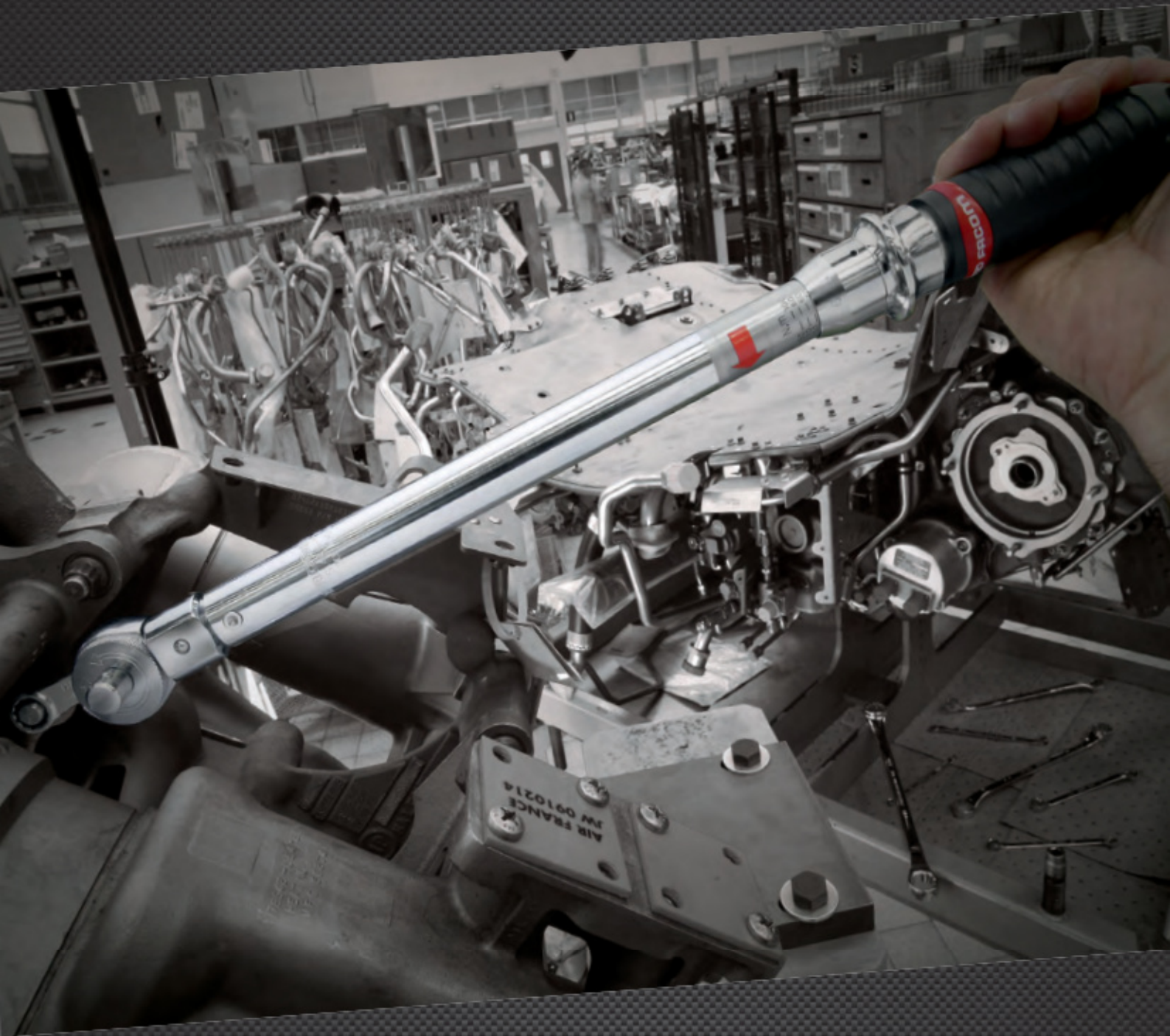

TORQUE CONTROL

SERVICES

366

- Selection guide 366
- Torque control guide 368
- Controlled torquing services 370



TORQUE WRENCHES

374

- "High performance" click wrenches 374
- "Multi-purpose" click wrenches 380
- Manual reset wrenches 381
- High-torque wrenches 383
- Torque multiplier 384
- "Non vernier" adjustable wrenches 386



ELECTRONIC TORQUE WRENCHES

388

- Electronic torque wrenches and adapters 388



RELEASE TYPE TORQUE DRIVER

392

- Release type torque driver 392
- "Non vernier" release type torque driver 395



ELECTRONIC TORQUE SCREWDRIVERS

396

- Electronic torque screwdrivers 396



ACCESSORIES

397

- Accessories 9 x 12 mm 398
- Accessories 14 x 18 mm 400
- Accessories 20 x 7 mm 402
- Crowfoot accessories 403
- Set of accessories 406



ANGULAR TIGHTENING WRENCHES

410

- Angular tightening wrenches 410



TORQUE CONTROLLERS

411

- Torque controllers 411



FLUO

RFid











SELECTION GUIDE

To find the right wrench for your application:

1 Choose the type of application

2 Choose the torque-setting method

1	VERNIER: VARIABLE TORQUE ADJUSTMENT						
2	5° RELEASE ANGLE					AUDIBLE AND VISUAL INDICATION	MANUAL RESET
3	50,000 Cycles ± 2% 9x12, 14x18, Ø30	50,000 Cycles ± 2% 20x7	50,000 Cycles ± 2% 9x12, 14x18lbf.in or lbf.ft	25,000 Cycles ± 4% Fixed ratchet	25,000 Cycles ± 4% 9x12, 14x18	15,000 Cycles ± 4% Ø30	100,000 Cycles ± 6% 20x7, Fixed drive
4							
0	306D	306R	306U	208	208D	200	203

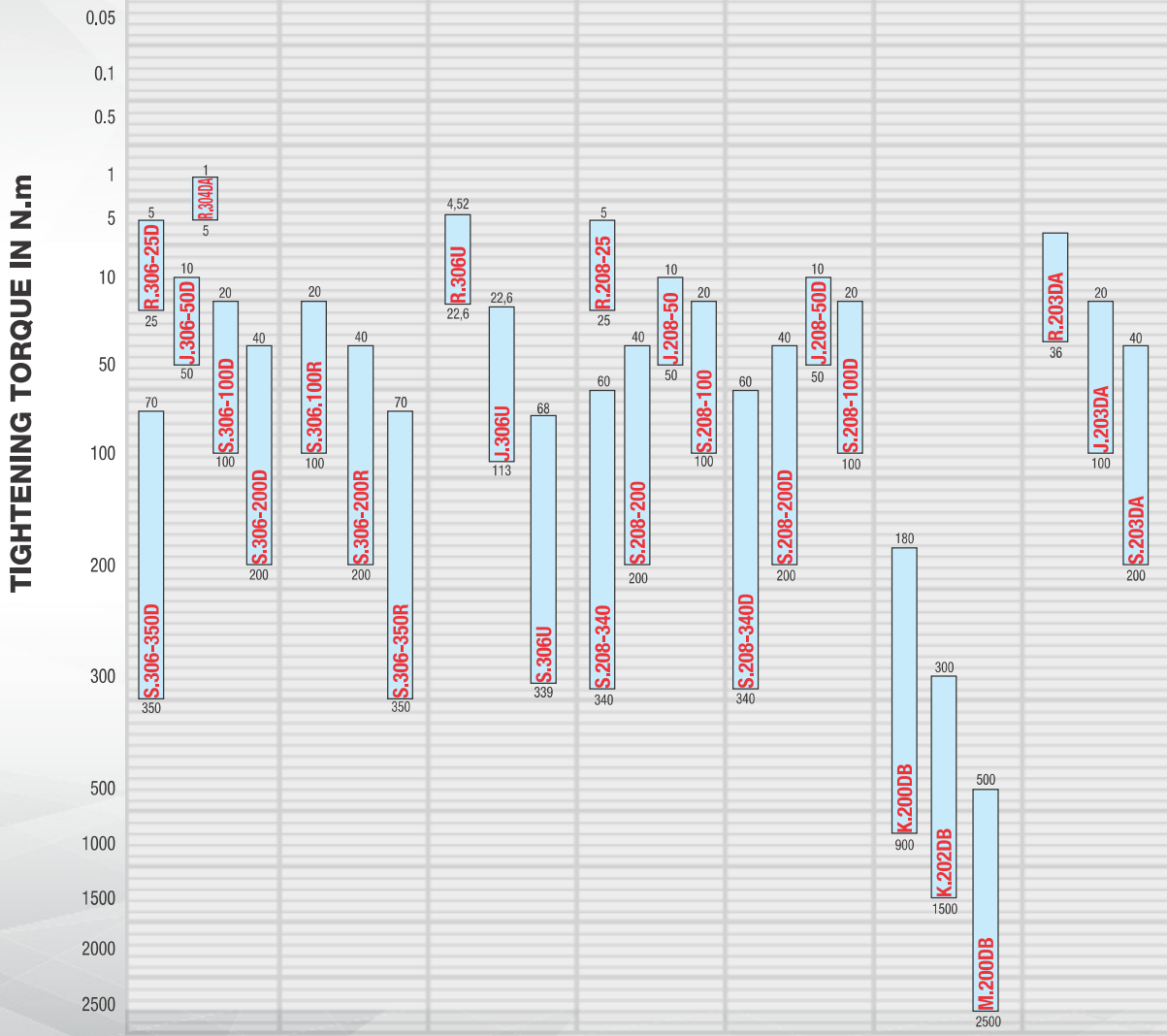

SELECTION GUIDE

3 Choose its characteristics
(Number of cycles, accuracy, end fitting)

4 Choose the torque range

RELEASE	TORQUE READING			NON VERNIER: REPETITIVE TIGHTENING TO THE SAME TORQUE		
	DIAL	ELECTRONIC		MECHANICAL		RELEASE
				5° "CLICK"	20° "BREAK"	
100 000 Cycles +/- 6% □ 4 mm, 1/4"	20 000 Cycles +/- 4% Fixed drive	25 000 Cycles +/- 2% 9x12, 14x18	10 000 Cycles +/- 3% Fixed drive	100 000 Cycles +/- 4% 9x12, 14x18	50 000 Cycles +/- 8% 9x12, 20x7	100 000 Cycles +/- 6% □ 4 mm, 1/4"
A.400 / A.300MT	E.306	E.316	E.506	248	446	A.440 / A.340MT

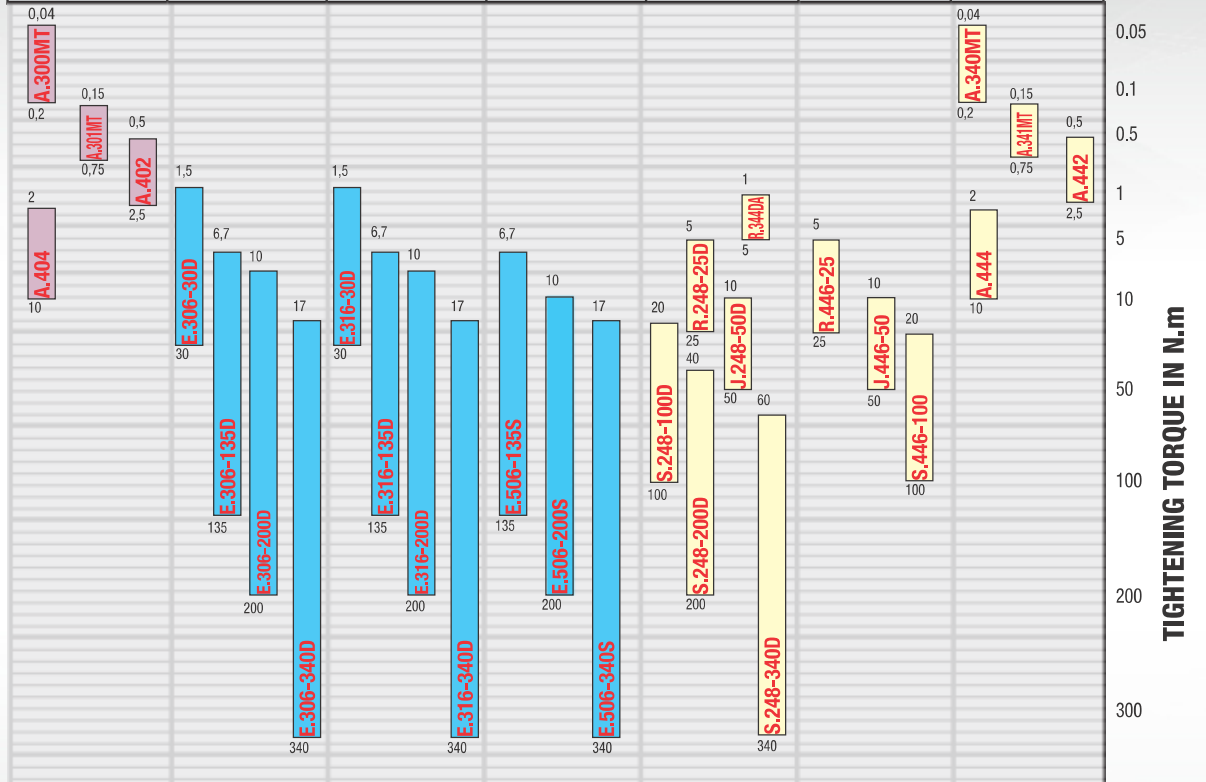

CALCULATION OF THE CORRECTION RATIO

When using a non-standard accessory or crowfoot, torque applied does not match torque set.

Torque applied =
Torque set to x $\frac{L \text{ Modified}}{L \text{ Standard}}$

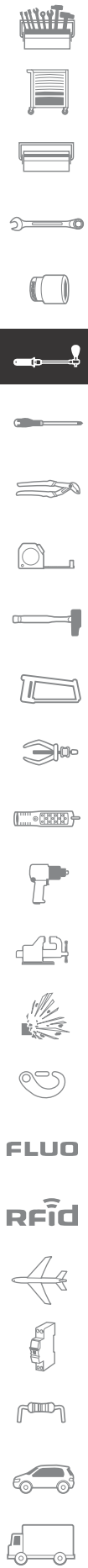
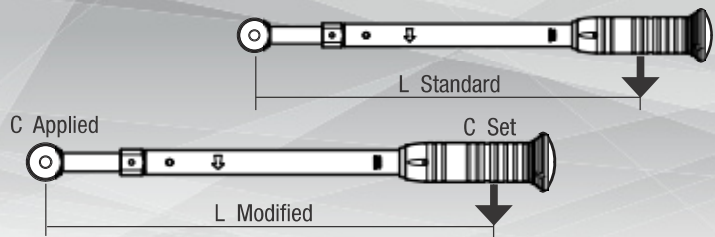

TORQUE CONTROL GUIDE



Tightening torque and tensile load

- Application of the correct force (tensile load) is essential for a reliable assembly:
 - under-tightened fasteners: can work loose
 - over-tight fasteners: may distort components to be connected, or shear the fastener.
- Tensile load depends on tightening torque applied to the fastener and the friction coefficient.

Tensile load (Fo)

The force in Newtons (N) which maintains pressure contact between assembled components.

Tightening torque (Cs)

The product of a force and the leverage length at which it is applied: Torque (N.m) = Force (in Newtons) x length (in metres).

3. Tightening torque (Cs).

Torque values are listed in Newton-meters (Nm) for each type of fastener. In the example given, the fastener would be tightened to a torque of 36 Nm.



Conversion table

The internationally accepted unit is the Newton-metre (Nm).

1. To convert Nm

- Newton-metres to Kilogramme-force metres: 1 N.m = 0.102 kgf.m
- Newton-metres to Pound-force feet: 1 N.m = 0.738 lbf.ft
- Newton-metres to Pound-force inches: 1 N.m = 8.851 lbf.in
- Newton-metres to Ounce-force inches: 1 N.m = 141.61 ozf.in

2. To convert kgf.m

- Kilogramme-force metres to Newton-metres: 1 kgf.m = 9.81 N.m
- Kilogramme-force metres to Pound-force feet: 1 kgf.m = 7.23 lbf.ft
- Kilogramme-force metres to Pound-force inches: 1 kgf.m = 86.8 lbf.in

3. To convert lbf.ft

- Pound-force feet to Newton-metres: 1 lbf.ft = 1.35 N.m
- Pound-force feet to Kilogramme-force metres: 1 lbf.ft = 0.138 kgf.m
- Pound-force feet to Pound-force inches: 1 lbf.ft = 12 lbf.in

4. To convert lbf.in

- Pound-force inches to Newton-metres: 1 lbf.in = 0.1129 N.m
- Pound-force inches to Kilogramme-force metres: 1 lbf.in = 0.0115 kgf.m
- Pound-force inches to Pound-force feet: 1 lbf.in = 0.083 lbf.ft
- Pound-force inches to Ounce-force inches: 1 lbf.in = 16 ozf.in

Tightening torque table:

Torque values are given for 85% fastener yield strength (documentation E 25-030).

1. Friction coefficient

Choose the appropriate table according to type of fasteners used (0.10, 0.15, or 0.20). Example: $\mu = 0.10$

2. Fastener grade

The grade of a fastener denotes its quality (best is 12.9). Check the appropriate column for the fasteners used. Example: fastener dia. 10, fastener grade

ISO 272			Steel fastener grades to ISO 898-1													
d mm	ISO mm	mm	5,6		5,8		6,8		8,8*		9,8**		10,9		12,9	
d mm	ISO mm	mm	Cs	Fo	Cs	Fo	Cs	Fo	Cs	Fo	Cs	Fo	Cs	Fo	Cs	Fo
1,6**	0,35	3,2	0,06	260	0,084	364	0,096	416	0,128	555	0,144	624	0,189	815	0,221	954
2**	0,4	4	0,126	432	0,177	604	0,202	690	0,27	921	0,303	1 036	0,396	1 352	0,463	1 582
2,5**	0,45	5	0,261	718	0,365	1 006	0,417	1 150	0,556	1 533	0,626	1 724	0,82	2 251	0,96	2 634
3	0,5	5,5	0,44	1 077	0,62	1 508	0,71	1 724	0,95	2 298	1,09	2 586	1,4	3 376	1,64	3 951
4	0,7	7	1,03	1 868	1,44	2 615	1,65	2 988	2,2	3 985	2,49	4 484	3,23	5 853	3,78	6 849
5	0,8	8	2,03	3 053	2,85	4 275	3,25	4 885	4,34	6 514	4,92	7 335	6,3	9 568	7,4	11 196
6	1	10	3,53	4 310	4,95	6 034	5,6	6 896	7,5	9 195	8,53	10 336	11	13 506	12,9	15 805
8	1,25	13	8,5	7 904	11,9	11 066	13,6	12 647	18,2	16 863	20,63	18 968	26	24 768	31	28 984
10	1,5	16	16,8	12 580	23	17 612	27	20 128	36	26 838	41	30 197	52	39 418	61	46 128
12	1,75	18	29	18 337	40	25 672	46	29 339	62	39 119	70	44 022	91	57 457	106	67 236
14	2	21	46	25 175	65	35 245	74	40 280	99	53 707	111	60 251	145	78 882	170	92 309
16	2	24	71	34 597	100	48 436	115	55 356	153	73 808	173	83 165	225	108 406	263	126 858
18	2,5	27	99	42 094	139	58 932	159	67 351	220	92 440			313	131 897	366	154 348
20	2,5	30	140	54 059	196	75 682	225	86 494	311	119 003			440	169 385	515	198 216
22	2,5	34	192	67 511	269	94 515	307	108 017	424	148 374			602	211 534	704	247 540
24	3	36	241	77 845	338	108 983	387	124 552	534	171 437			758	243 914	887	285 432
27	3	41	355	102 393	498	143 350	569	163 829	784	225 110			1 114	320 832	1 304	375 442
30	3,5	46	483	124 491	677	174 287	773	199 185	1 067	274 030			1 515	390 072	1 773	456 467
33	3,5	50	653	155 083	915	217 116	1 046	248 132	1 442	341 347			2 048	485 926	2 397	568 637
36	4	55	841	182 032	1 177	254 845	1 346	291 252	1 855	400 571			2 636	570 369	3 085	667 453
39	4	60	1 088	218 667	1 523	306 135	1 741	349 868	2 399	481 158			3 410	685 159	3 990	801 782
42**	4,5	65	1 348	250 311	1 887	350 435	2 156	400 497	2 965	550 683			4 223	784 306	4 941	917 805
45**	4,5	70	1 681	292 970	2 353	410 158	2 690	468 752	3 698	644 534			5 267	917 973	6 164	1 074 223
48**	5	75	2 032	329 254	2 845	460 956	3 251	526 807	4 470	724 359			6 367	1 031 663	7 450	1 207 265
52**	5	80	2 608	395 006	3 651	553 008	4 172	632 009	5 737	869 013			8 171	1 237 685	9 562	1 448 354
56**	5,5	85	3 255	456 159	4 557	638 622	5 208	729 854	7 161	1 003 549			10 199	1 429 298	11 935	1 672 582
60**	5,5	90	4 032	532 893	5 645	746 050	6 451	852 629	8 871	1 172 365			12 634	1 669 732	14 785	1 953 941
64**	6	95	4 856	602 793	6 798	843 911	7 769	964 470	10 683	1 326 146			15 215	1 888 753	17 805	2 210 243

$\mu = 0.10$ tightening torques for phosphated or galvanised fasteners with full lubrication ($\mu =$ average friction coefficient)

TORQUE CONTROL GUIDE



μ = 0.15 tightening torques for coated or bright fasteners fitted dry (μ = average friction coefficient)

ISO 272

Steel fastener grades to ISO 898-1

d mm	ISO mm	mm	5,6		5,8		6,8		8,8		9,8		10,9		12,9	
			Cs	Fo	Cs	Fo	Cs	Fo	Cs	Fo	Cs	Fo	Cs	Fo	Cs	Fo
1,6**	0,35	3,2	0,075	234	0,105	327	0,12	374	0,16	499	0,18	561	0,235	732	0,275	857
2**	0,4	4	0,159	388	0,222	544	0,254	621	0,339	829	0,381	932	0,498	1 217	0,582	1 424
2,5**	0,45	5	0,33	648	0,463	907	0,529	1 036	0,705	1 382	0,793	1 555	1,04	2 030	1,21	2 375
3	0,5	5,5	0,57	972	0,8	1 362	0,91	1 556	1,21	2 075	1,38	2 335	1,79	3 048	2,09	3 567
4	0,7	7	1,3	1 685	1,83	2 359	2,09	2 696	2,78	3 594	3,16	4 044	4,09	5 279	4,79	6 178
5	0,8	8	2,59	2 759	3,62	3 862	4,14	4 414	5,5	5 886	6,27	6 626	8,1	8 645	9,5	10 116
6	1	10	4,49	3 891	6,2	5 448	7,1	6 226	9,5	8 302	10,84	9 334	14	12 194	16,4	14 269
8	1,25	13	10,9	7 145	15,2	10 003	17,4	11 432	23	15 242	26,34	17 146	34	22 388	40	26 198
10	1,5	16	21	11 379	30	15 930	34	18 206	46	24 275	52	27 313	67	35 655	79	41 724
12	1,75	18	37	16 594	52	23 231	59	26 550	79	35 401	90	39 835	116	51 995	136	60 845
14	2	21	59	22 789	83	31 905	95	36 463	127	48 618	143	54 570	187	71 408	219	83 563
16	2	24	93	31 385	130	43 939	148	50 216	198	66 955	224	75 422	291	98 340	341	115 079
18	2,5	27	128	38 123	179	53 373	205	60 998	283	83 746			402	119 454	471	139 787
20	2,5	30	182	49 039	254	68 655	291	78 463	402	107 941			570	153 657	667	179 811
22	2,5	34	250	61 326	350	85 857	400	98 123	552	134 806			783	192 157	917	224 865
24	3	36	313	70 616	438	98 863	500	112 986	691	155 489			981	221 266	1 148	258 928
27	3	41	463	93 042	649	130 259	741	148 868	1 022	204 577			1 452	291 534	1 700	341 157
30	3,5	46	628	113 045	880	158 263	1 005	180 872	1 387	248 811			1 969	354 209	2 305	414 500
33	3,5	50	854	141 009	1 195	197 412	1 366	225 614	1 884	310 343			2 676	441 828	3 132	517 033
36	4	55	1 096	165 409	1 534	231 573	1 754	264 655	2 418	363 974			3 435	518 282	4 020	606 501
39	4	60	1 424	198 910	1 994	278 474	2 279	318 257	3 139	437 669			4 463	623 253	5 223	729 339
42**	4,5	65	1 760	227 588	2 464	318 624	2 816	364 141	3 872	500 694			5 515	713 110	6 453	834 491
45**	4,5	70	2 203	266 613	3 085	373 258	3 525	426 580	4 847	586 548			6 903	835 386	8 079	977 579
48**	5	75	2 659	299 530	3 722	419 342	4 254	479 248	5 849	658 966			8 330	938 528	9 748	1 098 277
52**	5	80	3 425	359 684	4 795	503 558	5 480	575 495	7 335	791 306			10 731	1 127 011	12 558	1 318 843
56**	5,5	85	4 270	415 172	5 978	581 240	6 832	664 275	9 394	913 378			13 379	1 300 871	15 656	1 522 296
60**	5,5	90	5 306	485 416	7 428	679 583	8 490	776 666	11 673	1 067 916			16 625	1 520 971	19 455	1 779 860
64**	6	95	6 382	548 969	8 935	768 556	10 212	878 350	14 041	1 207 731			19 998	1 720 102	23 402	2 012 885

μ = 0.20 tightening torques for coated or bright fasteners. (μ = average friction coefficient)

ISO 272

Steel fastener grades to ISO 898-1

d mm	ISO mm	mm	5,6		5,8		6,8		8,8		9,8		10,9		12,9	
			Cs	Fo	Cs	Fo	Cs	Fo	Cs	Fo	Cs	Fo	Cs	Fo	Cs	Fo
1,6**	0,35	3,2	0,086	210	0,12	294	0,137	335	0,183	447	0,206	503	0,269	657	0,315	769
2**	0,4	4	0,183	349	0,256	488	0,293	558	0,39	744	0,439	837	0,573	1 093	0,671	1 279
2,5**	0,45	5	0,383	582	0,536	815	0,612	931	0,816	1 242	0,918	1 397	1,2	1 824	1,4	2 134
3	0,5	5,5	0,66	874	0,92	1 224	1,06	1 399	1,41	1 866	1,6	2 099	2,07	2 740	2,43	3 207
4	0,7	7	1,51	1 514	2,11	2 120	2,42	2 422	3,22	3 230	3,66	3 635	4,74	4 744	5,5	5 552
5	0,8	8	3	2 481	4,2	3 473	4,81	3 970	6,4	5 293	7,27	5 958	9,4	7 774	11	9 098
6	1	10	5,2	3 498	7,2	4 893	8,3	5 598	11,1	7 464	12,57	8 392	16,3	10 962	19,1	12 828
8	1,25	13	12,6	6 426	17,7	8 997	20	10 283	27	13 710	30,62	15 423	39	20 137	46	23 565
10	1,5	16	25	10 238	35	14 334	40	16 382	53	21 843	61	24 575	78	32 082	92	37 542
12	1,75	18	43	14 934	60	20 908	69	23 895	92	31 860	105	35 849	136	46 795	159	54 760
14	2	21	69	20 514	97	28 719	111	32 822	148	43 763	167	49 142	218	64 277	255	75 218
16	2	24	108	28 280	152	39 592	174	45 248	232	60 331	262	67 944	341	88 611	399	103 694
18	2,5	27	149	34 324	209	48 054	239	54 919	330	75 421			469	107 549	549	125 856
20	2,5	30	213	44 188	298	61 863	341	70 700	471	97 253			667	138 456	781	162 023
22	2,5	34	293	55 298	411	77 418	470	88 478	648	121 574			920	173 269	1 077	202 762
24	3	36	366	63 630	513	89 083	586	101 809	809	140 084			1 148	199 376	1 343	233 313
27	3	41	544	83 910	762	117 474	871	134 257	1 201	184 517			1 706	262 920	1 997	307 672
30	3,5	46	737	101 914	1 032	142 679	1 180	163 062	1 628	224 292			2 311	319 331	2 704	373 685
33	3,5	50	1 004	127 210	1 406	178 094	1 607	203 536	2 216	279 953			3 148	398 593	3 684	466 438
36	4	55	1 288	149 174	1 803	208 844	2 060	238 679	2 840	328 236			4 036	467 413	4 723	546 973
39	4	60	1 677	179 487	2 348	251 282	2 683	287 179	3 697	394 919			5 255	562 393	6 150	658 119
42**	4,5	65	2 070	205 323	2 898	287 452	3 312	328 516	4 554	451 710			6 486	643 344	7 590	752 849
45**	4,5	70	2 596	240 641	3 635	336 897	4 154	385 025	5 712	529 410			8 136	754 008	9 520	882 350
48**	5	75	3 130	270 321	4 383	378 449	5 009	432 514	6 887	594 706			9 809	847 006	11 478	991 177
52**	5	80	4 041	324 763	5 657	454 668	6 465	519 620	8 889	714 478			12 661	1 017 590	14 816	1 190 797
56**	5,5	85	5 034	374 739	7 048	524 635	8 054	599 582	11 075	824 426			15 773	1 174 182	18 458	1 374 043
60**	5,5	90	6 266	438 337	8 772	613 672	10 026	701 340	13 785	964 342			19 634	1 373 457	22 976	1 607 237
64**	6	95	7 533	495 676	10 546	693 947	12 052	793 082	16 572	1 090 488			23 603	1 553 119	27 620	1 817 480

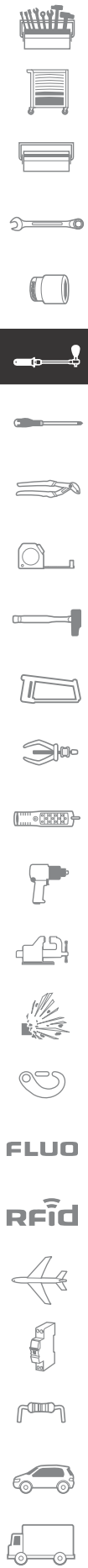

TORQUE SERVICES

Expertise is the key of trust

EA and bilateral recognition agreements

ACCREDITATION STANLEY
BLACK&DECKER FRANCE
N° 2-6503(*).
Scope available
on www.cofrac.fr



STANLEY BLACK&DECKER FRANCE has its own control laboratory at its site Morangis, France. This laboratory is accredited by COFRAC, signatory of the EA multilateral recognition agreement.

STANLEY BLACK&DECKER laboratory is your partner:

- For accurate torquing.
- For calibrating and regularly checking your tools in accordance with ISO requirements.
- For mutually recognised validity of tool calibration and inspection with European and other countries based on multilateral or bilateral recognition agreements (EA ; ILAC).
- For relating your tools back to the national and international (SI) system of units.



Periodical checking of your tools ensures peace of mind.

Note 1: For more details on the services offered by the laboratory, refer to the after-sales catalogue or the web site www.facom.com
Note 2: A calibration certificate issued with the COFRAC-ETALONNAGE logotype guarantees the results are related to the IS international unit system.

Signatories of the EA multilateral recognition agreement

- | | |
|--|--|
| COFRAC , Comité Français d'Accréditation | NA Norwegian Accreditation |
| DKD Deutscher Akkreditierungsrat | RVA Raad voor Accreditatie |
| ÖKD Bundes Ministerium für wirtschaftliche Angelegenheiten | IPAC Instituto Português de Acreditação |
| BKO Belgische Kalibratie Organisatie oboe Organisation Belge d'Etalonnage | CAI Czech Accreditation Institute |
| DANAK Danish Accreditation National Agency of Industry & Trade | UKAS United Kingdom Accreditation Service |
| ENAC Entidad Nacional de Acreditacion | SWEDAC Swedish Board for Accreditation & Conformity |
| FINAS Finnish Accreditation Service | SAS Swiss Accreditation Service |
| NAB National Accreditation Board | ESYD Hellenic Accreditation System |
| ACCREDIA Ente Italiano di Accreditamento | PCA Polskie Centrum Akredytacji |

Signatories to bilateral recognition agreements

- | | |
|---|--|
| NATA National Association of Testing Authorities | A2AL American Association for Laboratory |
| SANAS South Africa National Laboratory Accreditation Service | SAC Singapore Confederation of Industries |



REMINDER: When a tool sent under guarantee is functional and complies with our prescriptions, a manufacturer compliance certificate is supplied with the product, however this certificate cannot be used in lieu and place of a calibration certificate, nor control report. When a COFRAC accredited service is requested, it is invoiced, even when the wrench cannot be repaired. This service will not be invoiced when a new machine package (FMN) following this check has been accepted. Information on COFRAC accredited services is valid on the day the catalogue is printed.

(*) The use of COFRAC brand is submitted to strict rules. Any use needs previous approval.

COFRAC TORQUE SERVICES

Our laboratory offers different services within its COFRAC N° 2-6503 accreditation for measuring torque. The COFRAC calibration logotype guarantees direct relation of the results with the I.S. international unit system (linked with national and international calibres).

ACCREDITATION STANLEY
BLACK&DECKER FRANCE
N° 2-6503^(*).
Scope available
on www.cofrac.fr



1. COFRAC calibration certificate with declaration of conformity (3 or 10 points) for graduated tools by FACOM or other brands. In the 0.04 N.m to 3000 N.m accreditation range as per the ISO 6789 standard (*)

- Direct reading torque wrenches (type 1)- Dial- Electronic
- Vernier torque wrenches (type 2).
- Vernier torque drivers 0.04 N.m to 10 N.m.



2. Adjustment to the torque requested with Calibration certificate with COFRAC declaration of conformity (1 point). In the 0.04 N.m to 3000 N.m accreditation range as per the ISO 6789 standard (*)

- Non-vernier click torque wrenches (type 2) 1 N.m to 350 N.m.
- Vernier torque drivers 0.04 N.m to 10 N.m.



3. COFRAC calibration certificate for FACOM torque testers (please consult us for other makes). Within the 0.04 N.m to 5000 N.m accreditation range

- Electronic type E.4000 and E.5000- 0.1 N.m to 3,000 N.m.
- Electronic type E.2000- 2.5 N.m to 1000 N.m.
- Mechanical type CDS- 0.05 N.m to 12 N.m.



(*) For manual control torque tools with a maximum torque below or equal to 10 N.m, the means uncertainty (see p.7) can exceed $\pm 1\%$ specified in the ISO 6789 standard. In this case, the tolerance acceptable for the tool is reduced accordingly to guarantee conformity of the tool.

In case of partial request, an offer will be issued and the wrench kept for six weeks maximum. Then it will be returned.

(*) The use of COFRAC brand is submitted to strict rules. Any use needs previous approval.



FLUO

Rfid



COFRAC ACCREDITED SERVICES

Caution! The name of the user company must be specified when ordering a COFRAC calibration certificate.

ACCREDITATION STANLEY
BLACK&DECKER FRANCE
N° 2-6503(*).
Scope available
on www.cofrac.fr



FACOM make or other make

Torque wrenches and screwdrivers



Description	Uncertainty Method and means	Measuring range	
COFRAC 3-point calibration certificate with declaration of conformity for graduated tools	see table on next page	0,04 N.m to 360 N.m	CVC.RJS
		360 N.m to 3000 N.m	CVC.KM
COFRAC 10-point calibration certificate with declaration of conformity for graduated tools	see table on next page	0,04 N.m to 3000 N.m	CEC10.RJS
		360 N.m to 3000 N.m	CEC10.KM
Presetting with COFRAC1-point calibration certificate with declaration of conformity	see table on next page	0,04 N.m to 3000 N.m	PRER.CO

Torque controllers



Description	Uncertainty Method and means	Measuring range	
COFRAC calibration certificate torque meter 1 direction	see table on next page	0,04 N.m to 1000 N.m	CEC11
COFRAC calibration certificate torque meter 2 direction	see table on next page	0,04 N.m to 1000 N.m	CEC12
Facom E.5000 torque meter, 1 directions	see table on next page	10 N.m to 1000 N.m	CEC31
Facom E.5000 torque meter, 2 directions	see table on next page	10 N.m to 1000 N.m	CEC32

After analysis, any tool outside these accredited services may be given rise to writing an offer.

1 - Within the guarantee, this package includes:

The check as per procedures, NF EN ISO 6789 (except § 5.1.6: overload test and § 5.1.7: endurance test which are not applied) or specific procedures, validated by COFRAC.

Overhauling the tool if necessary.

A document with the values before and after intervention.

COFRAC calibration certificate with declaration of conformity for graduated tools or COFRAC calibration certificate in the case of torque meters.

Carriage to the distributor.

2 - For FACOM tools outside the framework of the guarantee and out of tolerance, overhauling will be subject to an offer.

If it is accepted: the cost of the service will correspond to the price of the repair package + price of the COFRAC calibration certificate with declaration of conformity for graduated tools or COFRAC calibration certificate in the case of torque meters.

If it is refused: the cost of the service will correspond, if the tool is functional, to the price of the COFRAC calibration certificate with declaration of conformity for graduated tools or COFRAC calibration certificate in the case of torque meters.

(*) The use of COFRAC brand is submitted to strict rules. Any use needs previous approval.

TABLES OF UNCERTAINTIES AND COFRAC ACCREDITED METHODS

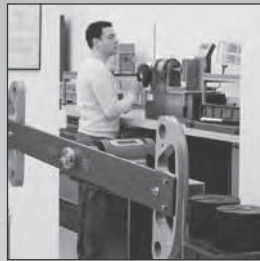

ACCREDITATION STANLEY
BLACK&DECKER FRANCE
N° 2-6503(*)
Scope available
on www.cofrac.fr



1. Calibration of manual control torque tools

Measuring range	Uncertainty of the means	Methods and means used
0.04 N.m to 1 N.m	$\pm (1.2 \cdot 10^{-3} \text{ N.m} + 4 \cdot 10^{-3} \cdot C)$	Comparison with the CALS 010 sensor no. 0108
0.5 N.m to 5 N.m	$\pm (6 \cdot 10^{-3} \text{ N.m} + 4 \cdot 10^{-3} \cdot C)$	Comparison with the CCS05 sensor no. 5191
1 N.m to 10 N.m	$\pm (6 \cdot 10^{-3} \text{ N.m} + 4 \cdot 10^{-3} \cdot C)$	Comparison with the CS1 sensor no. 1248
5 N.m to 50 N.m	$\pm 1 \cdot 10^{-2} \cdot C$	Comparison with the CS50 sensor no. 166
10 N.m to 100 N.m	$\pm 1 \cdot 10^{-2} \cdot C$	Comparison with the CS 100 sensor no. 135
15 N.m to 150 N.m	$\pm 1 \cdot 10^{-2} \cdot C$	Comparison with the CS 150 sensor no. 74
40 N.m to 400 N.m	$\pm 1 \cdot 10^{-2} \cdot C$	Comparison with the CS 400 sensor no. 134
100 N.m to 1000 N.m	$\pm 1 \cdot 10^{-2} \cdot C$	Comparison with the CS 1000 sensor no. 142
150 N.m to 1500 N.m	$\pm 1 \cdot 10^{-2} \cdot C$	Comparison with the CS 1500 sensor no. 150-8
400 N.m to 3000 N.m	$\pm 1 \cdot 10^{-2} \cdot C$	Comparison with the CS 3000 sensor no. 300-11

2. Calibration of torquemeters (torque measurement devices)

Measuring range	Uncertainty of the means	Methods and means used
0.04 N.m to 1 N.m	$\pm (10 \cdot 3 \text{ N.m} + 2 \cdot 10 \cdot 3 \cdot C)$	Suspended weight and disc system disc no. 21400
0.5 N.m to 50 N.m	$\pm (5 \cdot 10 \cdot 3 \text{ N.m} + 2 \cdot 10 \cdot 3 \cdot C)$	Suspended weight and arm system no. 21420
10 N.m to 150 N.m	$\pm (0.02 \text{ N.m} + 2 \cdot 10 \cdot 3 \cdot C)$	Suspended weight and arm system no. 21421
20 N.m to 1000 N.m	$\pm (0.06 \text{ N.m} + 2 \cdot 10 \cdot 3 \cdot C)$	Suspended weight and arm system no. 21428
150 N.m to 5000 N.m	$\pm (0.20 \text{ N.m} + 2 \cdot 10 \cdot 3 \cdot C)$	Suspended weight and arm system no. 21515
10 N.m to 100 N.m	$\pm (0.05 \text{ N.m} + 5 \cdot 10 \cdot 3 \cdot C)$	Comparison with a torquemeter reference HBM TB1A/100 no. 061730083 associated with the measurement bridge HBM MGC plus no. 019783
100 N.m to 1000 N.m	$\pm (0.05 \text{ N.m} + 5 \cdot 10 \cdot 3 \cdot C)$	Comparison with a torquemeter reference HBM TB1A/1000 no. 052830025 associated with the measurement bridge HBM MGC plus no. 019783

C = torque applied.

These 2 tables give indications on the measurement range of the means, the absolute uncertainty of the means, the method and means used to perform a task. Example: Torque wrench reference S.306-200D capacity 40 N.m to 200 N.m. Service requested (product designation): COFRAC calibration certificate FACOM graduated wrench.

- Service reference: CEC10.RJS Mark no.1 corresponds for the link with the tables.

Mark no.1 is located in table 1 containing the following indications:

- Means measurement range: 40 N.m to 400 N.m,
- Absolute uncertainty of the means: $\pm 1 \cdot 10^{-2} \cdot C$
- Method and means used: Comparison with the CS 400 sensor no. 134

CAUTION ! In case of partial request, an offer will be issued and the wrench kept for six weeks maximum. Then it will be returned.

(*) The use of COFRAC brand is submitted to strict rules. Any use needs previous approval.



FLUO

Rfid



SERIES 306 CLICK WRENCHES "HIGH PERFORMANCE"



**ISO 6789 Type II - Class A
Precision itself in heavy duty!**

HIGH PERFORMANCE

- Intensive use: reliability of mechanism tested to 50,000 cycles.
- Durable accuracy: remains within ISO 6789 tolerances after more than 5,000 cycles.
- Accuracy set at $\pm 2\%$ ex works.

SAFE

- Accurate, tamper-proof vernier. Easy to read and set for error-free adjustment.
- Automatically locking torque adjustment, no risk of accidental release.

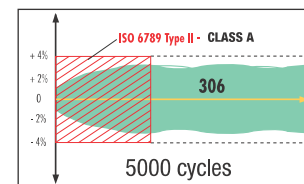

ERGONOMIC

- Ergonomic handle.
- Increased length for improved torque transfer and accuracy.
- Hanging ring for storage.

"HIGH PERFORMANCE" CLICK WRENCHES

306A - Click wrenches with removable ratchet

NF EN ISO 6789, ISO 6789, DIN EN ISO 6789

- Factory accuracy: $\pm 2\%$ except:
 - R.306-25D - K306-600D - K306-1000D ($\pm 4\%$).
 - R.304DA ($\pm 6\%$).
- Reliability of mechanism: 50 000 cycles (wrenches up to 200 N.m).
- Use possible with accessories:
 - End fitting: 9 x 12 or 14 x 18 mm.
 - Diameter: 30 mm.
- One-way wrenches usable for unscrewing by reversing the bits.
- Numbered wrenches supplied with ISO 6789 calibration certificate.
- Supplied in a plastic box with ratchet and hinged handle (except Ref R.306A25 - R.301A - K.306A600 - K.306A1000).

Ref	L [mm]	Attachment	Box	Capacity [N.m]	Wrench	Ratchet	Graduation [N.m]	Knob	$\Delta\Delta$ [kg]
R.301A	185	9 x 12	BP.102	1 - 5	R.304DA	R.372	0,05	-	0.290
R.306A25	271	9 x 12	BP.D1	5 - 25	R.306-25D	R.372	0,10	-	0.450
J.306A50	357	9 x 12	BP.D2	10 - 50	J.306-50D	J.372	1,00	S.305P	0,930
J.306A100	437	9 x 12	BP.D2	20 - 100	S.306-100D	J.372	1,00	S.305P	1.0
S.306A100	437	9 x 12	BP.D2	20 - 100	S.306-100D	S.372	1,00	S.305P	1.0
S.306A200	515	14 x 18	BP.D3	40 - 200	S.306-200D	S.382	1,00	S.305P	1.3
S.306A350	725	14 x 18	BP.D3	70 - 350	S.306-350D	S.382	2,00	S.305P	1.8
K.306A600	990	14 x 18	BP.D600	120 - 600	K.306-600D	K.382	2,00	-	5.2
K.306A1000	1280	\emptyset 30 mm	BP.D1000	200 - 1000	K.306-1000D	K.151B	4,00	-	5.9



306D - Click wrenches without accessories

NF EN ISO 6789, ISO 6789, DIN EN ISO 6789

- Factory accuracy: $\pm 2\%$ except:
 - R.306-25D - K.306A600 - K.306A1000 ($\pm 4\%$).
 - R.304DA ($\pm 6\%$).
- Reliability of mechanism: 50 000 cycles (wrenches up to 200 N.m).
- Use possible with accessories:
 - End fitting: 9 x 12 or 14 x 18 mm.
 - Diameter: 30 mm.
- One-way wrenches usable for unscrewing by reversing the bits.
- Numbered wrenches supplied with ISO 6789 calibration certificate.
- Supplied in plastic box.

Ref	L [mm]	Attachment	Box	Capacity [N.m]	Graduation [N.m]	$\Delta\Delta$ [kg]
R.304DA	185	9 x 12	BP.102	1 - 5	0,05	0.290
R.306-25D	271	9 x 12	BP.D1	5 - 25	0,10	0.450
J.306-50D	357	9 x 12	BP.D2	10 - 50	1,00	0.930
S.306-100D	437	9 x 12	BP.D2	20 - 100	1,00	1.0
S.306-200D	515	14 x 18	BP.D3	40 - 200	1,00	1.3
S.306-350D	725	14 x 18	BP.D3	70 - 350	2,00	1.8
K.306-600D	945	14 x 18	BP.D600	120 - 600	2,00	4.6
K.306-1000D	1280	\emptyset 30 mm	BP.D1000	200 - 1000	4,00	5.9

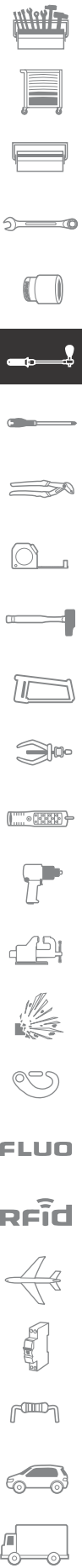

■ "Low torque" click wrench with fixed ratchet

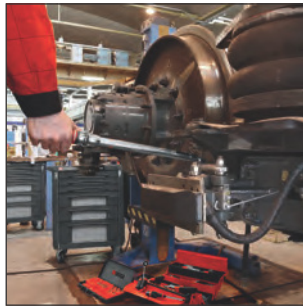

NF EN ISO 6789, ISO 6789, DIN EN ISO 6789

- Factory accuracy: $\pm 2\%$.
- Reliability of mechanism: 50,000 cycles.
- Compact wrench for confined access.
- Ratchet with 72 teeth (5°) for use with sockets.
- One-way wrench.
- Numbered wrench supplied with ISO 6789 calibration certificate.
- Supplied in a box, dim. (L. x W.): 205 x 120 mm.



ED	L [mm]	Box	Capacity [N.m]	Square ["]	Graduation [N.m]	$\Delta\Delta$ [g]
R.306-5	197	BP.102	1 - 5	1/4	0,05	300

■ S.306R - Click wrenches with attachment 20 x 7 mm



NF EN ISO 6789, ISO 6789, DIN EN ISO 6789

- Factory accuracy: $\pm 2\%$.
- Reliability of mechanism: 50,000 cycles (wrenches --> 200 N.m).
- Use possible with accessories attachment 20 x 7 mm.
- One-way wrenches usable for unscrewing by reversing the bits.
- Numbered wrenches supplied with ISO 6789 calibration certificate.
- Wrenches supplied in plastic protection tube.



ED	L [mm]	Attachment	Capacity [N.m]	Graduation [N.m]	$\Delta\Delta$ [kg]
S.306-100R	420	20 x 7	20 - 100	1	1.0
S.306-200R	510	20 x 7	40 - 200	1	1.3
S.306-350R	698	20 x 7	70 - 350	2	1.9

■ R-J-S.306U - Click wrenches with dual lbf.in or lbf.ft and N.m graduation.



NF EN ISO 6789, ISO 6789, DIN EN ISO 6789

- 72 tooth mechanism for 5° increments.
- Factory accuracy: $\pm 2\%$.
- Reliability of mechanism: 50,000 cycles.
- Click wrenches with dual lbf.in or lbf.ft and N.m graduation.
- Reversible model.
- Full metal wrenches with knurled handle.
- Numbered wrenches supplied with ISO 6789 calibration certificate.
- Supplied in plastic box with ratchet.



ED	L [mm]	Attachment	Box	Capacity [lbf.ft]	Capacity [lbf.in]	Square ["]	Graduation [lbf.ft]	Graduation [lbf.in]	$\Delta\Delta$ [kg]
R.306U	285	9 x 12	BP.D1	-	40 - 200	1/4	-	1	0.460
J.306U	379	9 x 12	BP.D2	-	200 - 1000	3/8	-	5	1.0
S.306U	600	14 x 18	BP.D3	30 - 250	-	1/2	1	-	1.6





306 SERIES WRENCH SETS

Each modular set comes in a steel case with one or two empty compartments that can each hold an additional module of sockets or other accessories.

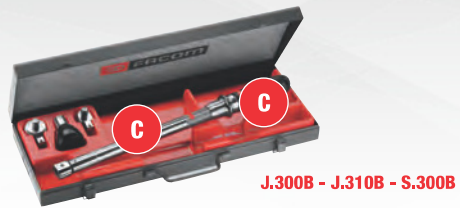
Building a set:

1. Check which size modules ("Modules" column) the set will take; e.g. S.300B takes 2 modules size C (C+C).
2. Choose modules of the correct size. For the S.300B, with 9 x 12 end fittings, one can choose e.g. S.300-2 and J.300-3 (both size C modules). See below.



MODULES / mm	A 9 x 5 mm	B 14 x 5 mm	C 15 x 10 mm	
	R.300-1 □ 1/4" Sockets 7-8-10-11-13 mm R.209 150 g		J.300-1 □ 3/8" Sockets 10-11-13-15-16-17-18-19 J.210 ΔΔ 540 g J.300-11 □ 3/8" Sockets 11-13-15-16-17-18-19-21-22 J.210 ΔΔ 680 g	S.300-1 □ 1/2" Sockets 11-13-15-16-17-18-19-21-22 S.210 ΔΔ 850 g S.300-11 □ 1/2" Sockets 16-17-18-19-21-22-24-27 S.210 ΔΔ 980 g
		R.300-2 Open ends no.10: 8-10-11-12-13 mm ΔΔ 200 g	J.300-2 Open ends no. 10: 11-13-15-16-17-18-19 mm ΔΔ 380 g	S.300-2 Open ends no.10: 11-13-15-16-17-18-19 mm ΔΔ 350 g
		R.300-3 Ring ends no.12: 8-10-11-12-13 mm ΔΔ 200 g	J.300-3 Ring ends no.12: 10-11-13-15-16-17-18-19 mm ΔΔ 380 g	S.300-3 Ring ends no.12: 11-13-15-16-17-18-19 mm ΔΔ 350 g
		R.300-4 □ 1/4" Hex bits RT: 3-4-5-6 mm ΔΔ 100 g	J.300-4 □ 3/8" Hex bits JT: 5-6-8-10 mm ΔΔ 190 g	S.300-4 1/2" Hex bits ST: 6-8-10-12 mm ΔΔ 330 g

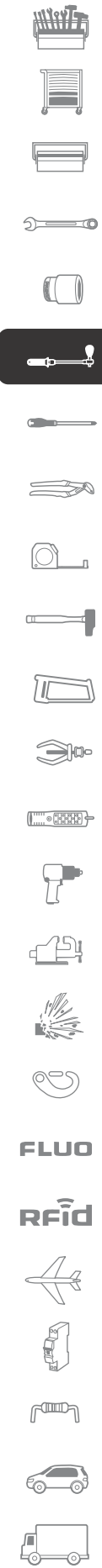





300B SERIES MODULAR SETS

Contents of 300B series modular sets:

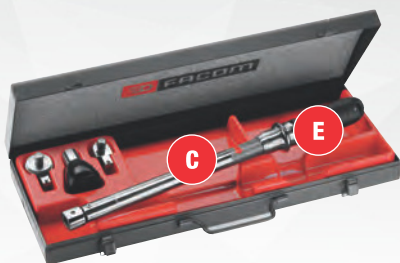
- 1 306D series wrench.1 ratchet,1 square drive, 1 pivot knob S.305P (except R.300B),
- 1 steel case with storage tray, (2 free compartments for modules).
- S.310B

Model	Capacity N.m	End fitting	Wrench	Content Ratchet	Square	Box set	Storage module	Kit	□ "	Module	ΔΔ kg
R.300B	5-25	9 x 12	R.306-25D	R.372	R.373	BP.115	PL.141A	322 x 128 x 50	1/4	A+B	1,5
J.300B	10-50	9 x 12	J.306-50D	J.372	J.373	BT.118	PL.140	470 x 175 x 55	3/8	C+C	3,1
J.310B	20-100	9 x 12	S.306-100D	J.372	J.373	BT.118	PL.137	470 x 175 x 55	3/8	C+C	3,3
S.300B	20-100	9 x 12	S.306-100D	S.372	S.373	BT.118	PL.137	470 x 175 x 55	1/2	C+C	3,3
S.310B	40-200	14 x 18	S.306-200D	S.382	S.383	BT.119	PL.138	625 x 175 x 55	1/2	C+E	4,4
S.320B	70-350	14 x 18	S.306-350D	S.382	S.383	BT.120	PL.139	770 x 175 x 55	1/2	D+F	5,3



MODULES / mm	D 24 x 10 mm	E 28 x 10 mm	F 39 x 10 mm
	S.300-21 □ 1/2" Sockets 17-18-19-21-22-24-27-30-32 mm S.210 ΔΔ 1300 g		
	K.300-2 Open ends 11: 22-24-27-30-32 mm ΔΔ 1020 g	S.300-12 Open ends 11: 16-17 18-19-21-22-24-27 mm ΔΔ 1280 g	S.300-22 Open ends 11: 17-18-19-21-22-24-27-30-32 mm ΔΔ 1580 g
		S.300-13 Ring ends 13: 16-17 - 18-19-21-22-24-27 mm ΔΔ 1140 g	S.300-23 Open ends 13: 17-18-19-21-22-24-27-30-32 mm ΔΔ 1,440 g K.300-3 Ring ends 13: 22-24-27-30-32-34-36 mm ΔΔ 1320 g
		S.300-14 □ 1/2" Hex. bits ST: 8-10-12 -14 mm ΔΔ 400 g	S.300-24 □ 1/2" Hex. Bits ST: 8-10-12-14-17 mm ΔΔ 540 g

SERIES 208 CLICK WRENCH "MULTI-PURPOSE"



ISO 6789
Type II - CLASS A
The compact
wrench for all
applications

Heavy-duty

- Reliability of mechanism tested to 25000 cycles.
- Resistant to all hydrocarbons for use in garages or industrial environments.

2 series:



• With fixed ratchet.



• With removable ratchet.



Reliable

- Accurate to within $\pm 4\%$ in accordance with ISO 6789.
- Long-lasting accuracy.
- Double (coarse and fine) vernier adjustment.



Compact

- Shorter and lighter for working in congested spaces.
- Fixed ratchet version with a smaller head.

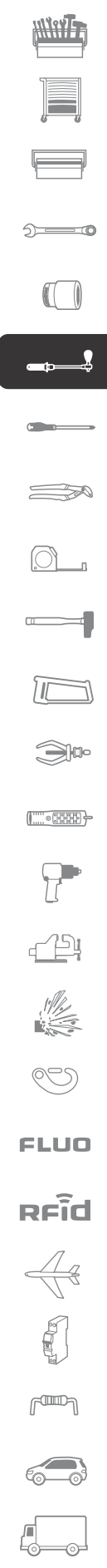

FLUO

Rfid

"MULTI-PURPOSE" CLICK WRENCHES

■ R-J-S.208 - Click wrenches with fixed ratchet



NF EN ISO 6789, ISO 6789, DIN EN ISO 6789

- Accuracy: ± 4%.
- Reliability of mechanism 25 000 cycles.
- Ratchet with 72 teeth (5° increment) for use with sockets.
- One-way wrenches.
- Sensitive sound click when reaching torque.
- Automatic reset.
- Supplied with ISO 6789 calibration certificate.
- Supplied in plastic protection tube.



ED	L [mm]	Capacity [N.m]	Square ["]	Graduation [N.m]	ΔΔ [kg]
R.208-25	300	5 - 25	1/4	0,1	0.500
J.208-50	357	10 - 50	3/8	0,5	0.780
S.208-100	416	20 - 100	1/2	1,0	1.0
S.208-200	479	40 - 200	1/2	2,0	1.2
S.208-340	632	60 - 340	1/2	2,0	1.5

■ J-S.208D - Click wrenches without accessories



NF EN ISO 6789, ISO 6789, DIN EN ISO 6789

- Accuracy: ± 4%.
- Reliability of mechanism 25 000 cycles.
- End fitting: 9 x 12 or 14 x 18 mm for accessories (ratchets, polygon and open end bits).
- One-way wrenches usable for unscrewing by reversing the bits.
- Sensitive sound click when reaching torque.
- Automatic reset.
- Supplied with ISO 6789 calibration certificate.
- Supplied in plastic protection tube.



ED	L [mm]	Attachment	Capacity [N.m]	Graduation [N.m]	ΔΔ [kg]
J.208-50D	337	9 x 12	10 - 50	0,5	0.780
S.208-100D	396	9 x 12	20 - 100	1,0	0.920
S.208-200D	466	14 x 18	40 - 200	2,0	1.1
S.208-340D	618	14 x 18	60 - 340	2,0	1.4

■ J-S.208A - Click wrenches with removable ratchet



NF EN ISO 6789, ISO 6789, DIN EN ISO 6789

- Accuracy: ± 4%.
- Reliability of mechanism 25 000 cycles.
- End fitting: 9 x 12 or 14 x 18 mm for accessories (ratchets, polygon and open end bits).
- One-way wrenches usable for unscrewing by reversing the bits.
- Sensitive sound click when reaching torque.
- Automatic reset.
- Supplied with ISO 6789 calibration certificate.
- Supplied in plastic protection tube with ratchet.



ED	L [mm]	Attachment	Capacity [N.m]	Square ["]	Wrench	Ratchet	Graduation [N.m]	ΔΔ [kg]
J.208A50	337	9 x 12	10 - 50	3/8	J.208-50D	J.372V	0,5	0.780
S.208A100	396	9 x 12	20 - 100	1/2	S.208-100D	S.372V	1,0	0.920
S.208A200	466	14 x 18	40 - 200	1/2	S.208-200D	S.382V	2,0	1.1
S.208A340	618	14 x 18	60 - 340	1/2	S.208-340D	S.382V	2,0	1.4

MANUAL RESET WRENCHES

MANUAL RESET WRENCH



The simple, heavy-duty wrench

Simple and reliable

- Strong, dependable wrenches.
- Accuracy to within $\pm 6\%$ of the reading in accordance with ISO 6789.
- Numbered and supplied with a calibration certificate.

Triple signal

- Release of the rocker when preset torque is reached produces a triple visual, sensory and audible signal.
- Clear graduated scale ensures precise torque settings.
- Scale pointer movement helps to monitor torque increase.

R-J-S.203DA - Manual reset wrenches

- Accuracy: $\pm 6\%$.
- R.203A wrench, graduated in N.m. with fixed square.
- J.203A - S.203A wrenches, graduated in daN.m.
- Supplied in plastic storage case with ISO 6789 calibration certificate.

Model	L [mm]	Box	Capacity [daN.m]	Square ["]	Graduation	$\Delta\Delta$ [g]
R.203DA	320	BP.D5	0,6 - 3,6	1/4	2,0 N.m	300
J.203DA	440	BP.D5	2 - 10	3/8	0,5 daN.m	800
S.203DA	460	BP.D5	4 - 20	1/2	1,0 daN.m	900

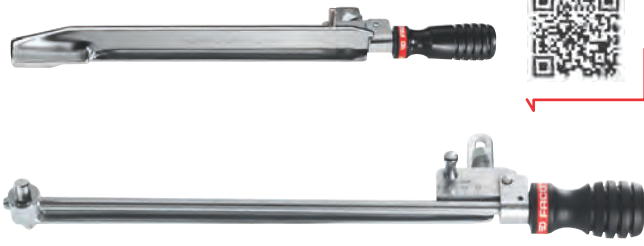

R-J-S.203A - Manual reset wrenches with square drive and handle

NF EN ISO 6789, ISO 6789, DIN EN ISO 6789

- Accuracy: $\pm 6\%$ value displayed.
- R.203A wrench, graduated in N.m.
- J.203A - S.203A wrenches, graduated in daN.m.
- Supplied in plastic storage case with ISO 6789 calibration certificate.



Model	L [mm]	Box	Capacity [daN.m]	Square	Square ["]	Wrench	Graduation	Knob	$\Delta\Delta$ [kg]
R.203A	320	BP.D5	0,6 - 3,6	-	1/4	R.203DA	2,0 N.m	R.200P	0.400
J.203A	440	BP.D5	2 - 10	J.203E	3/8	J.203DA	0,5 daN.m	S.200P	0.950
S.203A	460	BP.D5	4 - 20	S.203E	1/2	S.203DA	1,0 daN.m	S.200P	1.0



SJ-K214 - Extension for 203 series wrench

- Can double or triple the capacity of wrenches ref J.203DA - S.203DA.
- Use with:
 - 152 ratchets.
 - Bits series 20: SJ.214.
 - Sockets 3/4": K.214A.



Model	L [mm]	Capacity [daN.m]	$\Delta\Delta$ [kg]
SJ.214	400	x2	0.680
K.214A	860	x3	3.0



MANUAL RESET WRENCHES

■ J-S.202A - Manual click wrenches with removable ratchet



NF EN ISO 6789, ISO 6789, DIN EN ISO 6789

- Accuracy: $\pm 6\%$ value displayed.
- 1/4" square wrench: see product ref R.203A.
- Supplied in plastic storage case with ISO 6789 calibration certificate.

ED	L [mm]	Box	Capacity [daN.m]	Square ["]	Wrench	Ratchet	Graduation	$\Delta\Delta$ [kg]
J.202A	460	BP.D5	2-10	3/8	J.203DA	J.152	0,5 daN.m	1.0
S.202A	470	BP.D5	4-20	1/2	S.203DA	S.152	1,0 daN.m	1.1

■ R-J-S.205E - Modular sets with sockets



NF EN ISO 6789, ISO 6789, DIN EN ISO 6789

- Each of these sets has a free slot for an additional bit module.
- Choice of module and size (refer to the table).
- Supplied with a handle:
 - R.200P (R.205E).
 - S.200P (J.205E - S.205E).
- Supplied with extension SJ.214 (except R.205E).
- Supplied in a grey metal box.

ED	Box	Capacity [daN.m]	Square ["]	Wrench	Socket	Tray	$\Delta\Delta$ [kg]
R.205E	BT.112G	0,6 - 3,6	1/4	R.203DA	R.300.1	PL.142	1.4
J.205E	BT.118	2 - 10	3/8	J.203DA	J.300.11	PL.136	4.3
S.205E	BT.119	4 - 20	1/2	S.203DA	S.300.11	PL.135	4.7

SERIES 200 HIGH-TORQUE WRENCH



High-torque wrench

Comfort of use

- Large dial.
- Separate N.m and lbf.ft scales.
- Accurate to within $\pm 4\%$ of the reading in accordance with ISO 6789.
- Light signal on reaching preset torque.

Sturdy

- Large round end fitting $\varnothing 30$ mm.
- Optional use with jack or lifting gear.

TORQUE WRENCHES

HIGH-TORQUE WRENCHES

■ **KM.B - High-torque wrenches with ratchet and drive square**

NF EN ISO 6789, ISO 6789, DIN EN ISO 6789

- Accuracy: ± 4 % value displayed.
- Two reading scales: N.m and lbf.ft.
- Large size dial.
- Light alarm when reaching torque.
- Cylindrical attachment diameter 30 mm.
- Numbered wrenches supplied with calibration certificate.
- Wrenches supplied in metal case with storage module, dim. (L. x W. x H.): 760 x 220 x 140 mm.

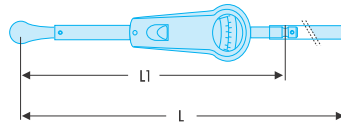

Model	L [mm]	L1 [mm]	Box	Capacity [lbf.in]	Capacity [N.m]	Square	Square ["]	Wrench	Ratchet	Handle	ΔΔ Tray	ΔΔ [kg]
K.201B	1019	595	BT.102	150 - 650	180 - 900	K.200E	3/4	K.200DB	K.151B	K.200MA	PL.549	8.0
K.203B	1019	595	BT.102	250 - 1100	300 - 1500	K.200E	3/4	K.202DB	K.151B	K.202MA	PL.549	8.0
M.201B	-	724	BT.102	300 - 1800	500 - 2500	M.200EA	1	M.200DB	M.151	-	PL.549	18,000

■ **KM.B - High-torque wrenches with drive square**

NF EN ISO 6789, ISO 6789, DIN EN ISO 6789

- Accuracy: ± 4 % value displayed.
- Two reading scales: N.m and lbf.ft.
- Large size dial.
- Light alarm when reaching torque.
- Cylindrical attachment diameter 30 mm.
- Numbered wrenches supplied with calibration certificate.
- Wrenches supplied in metal case with storage module, dim. (L. x W. x H.): 760 x 220 x 140 mm.

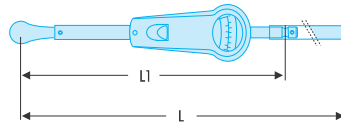

Model	L [mm]	L1 [mm]	Box	Capacity [lbf.ft]	Capacity [N.m]	Square	Square ["]	Wrench	Handle	ΔΔ Tray	ΔΔ [kg]
K.200B	1019	595	BT.102	150 - 650	180 - 900	K.200E	3/4	K.200DB	K.200MA	PL.549	6.2
K.202B	1019	595	BT.102	250 - 1100	300 - 1500	K.200E	3/4	K.202DB	K.202MA	PL.549	6.3
M.200B	-	724	BT.102	300 - 1800	500 - 2500	M.200EA	1	M.200DB	-	PL.549	13,00

■ **KM.DB - High-torque wrenches without accessories**

NF EN ISO 6789, ISO 6789, DIN EN ISO 6789

- Accuracy: ± 4 % value displayed.
- Two reading scales: N.m and lbf.ft.
- Large size dial.
- Light alarm when reaching torque.
- Cylindrical attachment diameter 30 mm.
- Numbered wrenches supplied with calibration certificate.

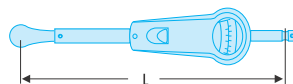

Model	L [mm]	Capacity [lbf.ft]	Capacity [N.m]	Graduation [lbf.ft]	Graduation [N.m]	ΔΔ [kg]
K.200DB	595	150 - 650	180 - 900	25	25	3.6
K.202DB	595	250 - 1100	300 - 1500	50	50	4.7
M.200DB	724	300 - 1800	500 - 2500	100	100	5.7

■ **Handle for wrench M.200DB**

- Telescopic handle gives up to 3m leverage including length of wrench.
- Complete with fasteners.



Model	ΔΔ [kg]
M.200M	8,144

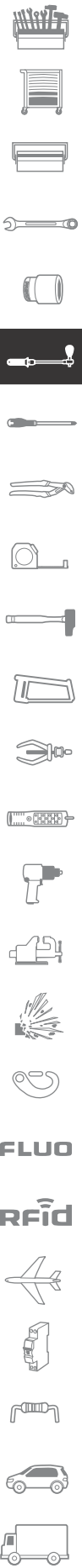

TORQUE MULTIPLIERS



For high tightening and loosening torques without an external power source

More accurate, safer and more compact

- Slow, gentle torque application ensures improved accuracy.
- Reduced lever arm compared to a high-torque wrench ensures operator safety.
- Reduced size allows multipliers to be used where high torque wrenches cannot reach.



Type MC

- Compact and lightweight for awkward spaces.
- With stop lever.



Type NP

- Input torque limiter to protect the mechanism.
- Non-return system for increased safety.
- Lifetime-lubricated mechanism for ease of maintenance.
- Supplied with two reaction arms, one straight and one offset.



TORQUE MULTIPLIER

TORQUE MULTIPLIER SELECTION GUIDE

Required input torque: $\text{input torque} = \frac{\text{output torque}}{\text{multiplying factor}}$

Example: Specified tightening torque: 2000 N.m Model NP.300B
 → Input torque = $2000 / 25 = 80 \text{ N.m.}$

Model	Input drive	Output drive	Accuracy	Multiplying factor	Max. input torque	Max. output torque
MC.130B	1/2"	3/4"	+/-4%	5	260	1300
MC.270B	3/4"	1"	+/-4%	5	540	2700
NP.100B	1/2"	3/4"	+/-4%	25	40	1000
NP.200B	1/2"	1"	+/-4%	25	80	2000
NP.300B	1/2"	1"	+/-4%	25	120	3000
NP.600B	1/2"	1 1/2"	+/-4%	25	240	6000

Warning

- For your safety, use only impact grade sockets and accessories. Always lock sockets with the appropriate pin and ring.
- Never use manual or pneumatic impact wrenches with this type of tool.



■ MC.B Torque Multiplier

- Compact and lightweight models suited to maintenance work on vans and trucks.
- Multiplication ratio: 5:1.
- Supplied with 2 reaction arms (straight and angled) and one spare drive square.



Model	A [mm]	B [mm]	C [mm]	d [mm]	L [mm]	ΔΔ [kg]
MC.130B	126	263	180	106	396	3.8
MC.270B	128	263	186	106	396	3.8

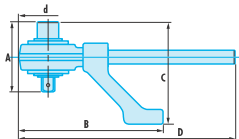

■ NP.B - Sets with torque multiplier

- Powerful tightening and untightening without external energy source.
- Constant multiplication ratio: 25:1.
- Safety: input torque limiter.
- Non-return system.
- Rate = 25:1.
- Supplied with 2 reaction arms (straight and angled) and one spare drive square, with a compliance certificate.

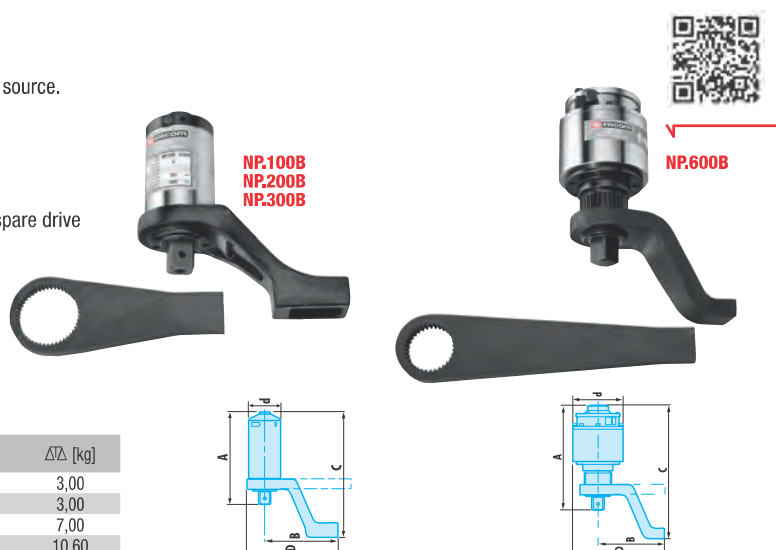

Model	A [mm]	B [mm]	C [mm]	d [mm]	ΔΔ [kg]
NP.100B	174	165	218	72	3,00
NP.200B	174	165	218	72	3,00
NP.300B	224	141	285	108	7,00
NP.600B	271	154	351	119	10,60

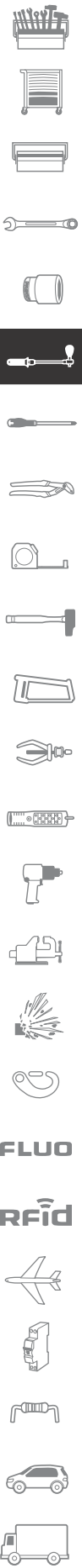
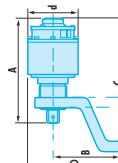
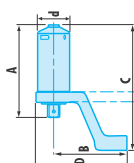

248 AND 446 SERIES ADJUSTABLE WRENCHES "NON GRADUATED"

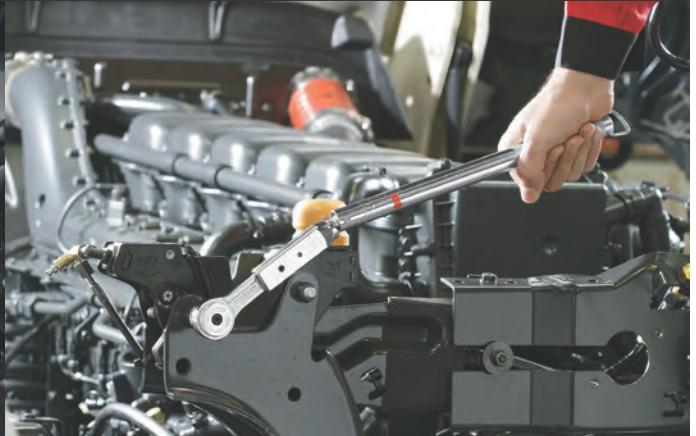

Compact, durable production wrenches

248 series ▶



248 series

- 5° release angle.
- 9x12 and 14x18 end fittings.
- Accuracy $\pm 4\%$.

446 series ▼

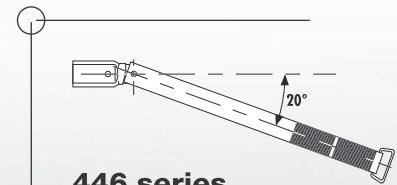

446 series

- Wide (20°) release angle.
- 20x7 end fitting
- Accuracy $\pm 8\%$.

Durable

- For intensive and repetitive use, tested to over 100,000 cycles.

Compact and lightweight

- Shorter and more compact for working in confined spaces.
- Reduced weight for increased comfort when performing intensive tasks.

Safe

- Non-graduated preset torque wrenches for production applications.
- Preset with a hex key and a torque meter, no risk of accidentally altering settings.
- Touch and sound signals on release: can be used in noisy and poor visibility conditions.



"NON VERNIER" ADJUSTABLE WRENCHES

"Non vernier" adjustable click wrenches



NF EN ISO 6789, ISO 6789, DIN EN ISO 6789

- Accuracy: $\pm 4\%$.
- Proven reliability: 100,000 cycles.
- End fitting: 9 x 12 or 14 x 18 mm.
- Wrenches which can be preset and used in tightening and untightening.
- Torque adjustment with a key using a control bench, see range of torque controllers.
- Knurled metal handle.
- Numbered wrenches supplied in plastic protection tube.

Model	L [mm]	Attachment	Capacity [lbf.ft]	Capacity [lbf.in]	Capacity [N.m]	$\Delta\Delta$ [kg]
R.344DA	200	9 x 12	-	10 - 50	1 - 5	0.240
R.248-25D	250	9 x 12	-	45 - 220	5 - 25	0.280
J.248-50D	331	9 x 12	-	90 - 440	10 - 50	0.740
S.248-100D	399	9 x 12	15 - 74	-	20 - 100	0.880
S.248-200D	464	14 x 18	30 - 148	-	40 - 200	1.1
S.248-340D	618	14 x 18	44 - 250	-	60 - 340	1.4

R-J-S.446 - "Non vernier" wide angle adjustable wrenches



NF EN ISO 6789, ISO 6789, DIN EN ISO 6789

- Accuracy: $\pm 8\%$.
- Proven reliability: 50,000 cycles.
- End fitting: 9 x 12 or 20 x 7 mm.
- Wrenches adjustable with a torquemeter, see range of torque controllers.
- Wrenches supplied with ISO 6789 calibration certificate.
- Wrenches supplied in plastic protection tube.

Model	L [mm]	Attachment	Capacity [N.m]	Square ["]	$\Delta\Delta$ [g]
R.446-25	214	9 x 12	5 - 25	1/4	380
J.446-50	279	20 x 7	10 - 50	3/8	490
S.446-100	407	20 x 7	20 - 100	1/2	840



FLUO

Rfid



ELECTRONIC RANGE - WRENCHES AND ADAPTERS



FACOM offer an electronic range, for high productivity and accuracy. Torque range from 1.5 to 340 N.m.



In confined spaces, our wrenches and adapters provide torque or angle increments.



E.306 series
• For electronic precision in torque tightening.



E.316 series
• A single tool for torque & angle tightening for high productivity.



E.506 series
• For occasional torque & angle tightening.



E.406 series
• For basic angular tightening.



- The electronic display prevents reading errors.
- Tightening is indicated by the LEDs and buzzer (in all 4 series).
- Easy to use through the same user interface on all models.

Why use torque/angle tightening ?

Angle tightening eliminates friction issues related with torque tightening. The movement, and hence fastener tension, is defined by the screw pitch and tightening angle.

Torque/angle tightening is performed in 2 steps:

- Pre-torquing to approach the parts and eliminate interface faults.
- Then tightening at a specific angle. Proper assembly tension prevents the fastener from loosening or breaking.

ELECTRONIC RANGE - WRENCHES AND ADAPTERS



E.306 and E.316 series

- 9 torque and/or angle values can be preset.
- 250 results can be saved, downloaded via USB.



Interchangeable end.

Electronic display LED & buzzer.

Locking keypad on E.316 series.

Ergonomic handle.

Gyroscope for angular reading.

2 AA-LR6 1.5V batteries.

E.506 series

- 9 torque and/or angle values can be preset.
- 50-result memory.



Locking keypad.

Electronic display LED & buzzer.

2 AAA-LR03 1.5V batteries.

Gyroscope for angular reading.

E.406 series

- 9 preset angle values.
- 50-result memory.



Electronic display LED & buzzer.

2 AAA-LR03 1.5V batteries.

Gyroscope for angular reading.

Magnetised tool (ratchet) fastening.

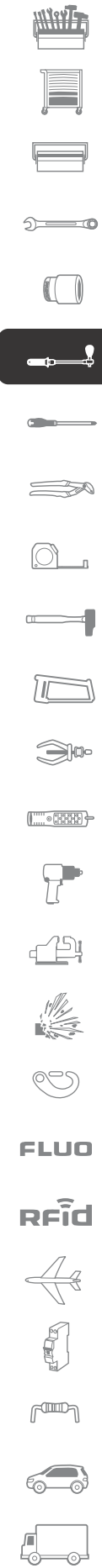

FLUO

RFid

ELECTRONIC TORQUE WRENCHES AND ADAPTERS

E.306D - Electronic torque wrenches



NF EN ISO 6789, ISO 6789, DIN EN ISO 6789

- Accuracy: $\pm 2\%$ between 20% and 100% wrench capacity.
- Measuring mode: peak or follower.
- Measuring unit: N.m, lbf.ft, lbf.in and kg.cm.
- Bits: 9 x 12 and 14 x 18 mm.
- Numbered wrenches supplied with ISO 6789 calibration certificate.
- Presetting possible of 9 torque values.
- Memory 250 values with PC USB link.
- Supplied in plastic case with foam interior.

➤	L [mm]	Capacity [N.m]	$\Delta\Delta$ [kg]
E.306-30D	360	1,5 - 30,0	1.5
E.306-135D	375	6,7 - 135,0	1.5
E.306-200D	474	10 - 200	2.4
E.306-340D	594	17 - 340	2.6

E.306A - Electronic torque wrenches with ratchet



NF EN ISO 6789, ISO 6789, DIN EN ISO 6789

- Accuracy: $\pm 2\%$ between 20% and 100% wrench capacity.
- Measuring mode: peak or follower.
- Measuring unit: N.m, lbf.ft, lbf.in and kg.cm.
- Bits: 9 x 12 and 14 x 18 mm.
- Numbered wrenches supplied with ISO 6789 calibration certificate.
- Presetting possible of 9 torque and/or angle values.
- Memory 250 values with PC USB link.
- Supplied in plastic case with foam interior.

➤	L [mm]	Capacity [N.m]	Square ["]	Ratchet	$\Delta\Delta$ [kg]
E.306A30R	390	1,5 - 30,0	1/4	R.372	1.6
E.306A135J	415	6,7 - 135,0	3/8	J.372V	1.7
E.306A135S	415	6,7 - 135,0	1/2	S.372V	1.7
E.306A200S	530	10 - 200	1/2	S.382V	2.7
E.306A340S	650	17 - 340	1/2	S.382V	2.9

E.316D - Electronic torque / angle wrenches



NF EN ISO 6789, ISO 6789, DIN EN ISO 6789

- Accuracy:
 - Torque: $\pm 2\%$ between 20% and 100% wrench capacity.
 - Angle: $\pm 2^\circ$.
- End fitting: 9 x 12 and 14 x 18 mm.
- Measuring mode: peak or follower.
- Locking keypad (the operator has access only to program choices and result memorising).
- Measuring unit: N.m, lbf.ft, lbf.in, kg.cm and deg.
- Presetting possible of 9 torque and/or angle values.
- Memory 250 values with PC USB link.
- Supplied with calibration certificate.
- Supplied in plastic case and foam module.

	L [mm]	Capacity [N.m]	$\Delta\Delta$ [kg]
E.316-30D	360	1,5 - 30,0	1,5
E.316-135D	375	6,7 - 135,0	1,5
E.316-200D	474	10 - 200	2,4
E.316-340D	594	17 - 340	2,6

E.316A - Electronic torque / angle wrenches with ratchet



NF EN ISO 6789, ISO 6789, DIN EN ISO 6789

- Accuracy:
 - Torque: $\pm 2\%$ between 20% and 100% wrench capacity.
 - Angle: $\pm 2^\circ$.
- End fitting: 9 x 12 and 14 x 18 mm.
- Measuring mode: peak or follower.
- Locking keypad (the operator has access only to program choices and result memorising).
- Measuring unit: N.m, lbf.ft, lbf.in, kg.cm and deg.
- Presetting possible of 9 torque and/or angle values.
- Memory 250 values with PC USB link.
- Supplied with calibration certificate.
- Supplied in plastic case and foam module.

	L [mm]	Capacity [N.m]	Square ["]	Ratchet	$\Delta\Delta$ [kg]
E.316A30R	390	1,5 - 30,0	1/4	R.372	1,6
E.316A135J	415	6,7 - 135,0	3/8	J.372V	1,7
E.316A135S	415	6,7 - 135,0	1/2	S.372V	1,7
E.316A200S	530	10 - 200	1/2	S.382V	2,7
E.316A340S	650	17 - 340	1/2	S.382V	2,9

E.406 - Electronic angle adapter



- Accuracy: $\pm 2^\circ$.
- Angular range: 1 – 360°.
- Measuring unit: degree.
- Accuracy: 0,1°.
- Presetting possible of 9 angle values.
- Memory 50 values.
- Supplied in plastic case with calibration certificate.

	$\Delta\Delta$ [g]
E.406	388

E.506 - Electronic torque / angle adapter



NF EN ISO 6789, ISO 6789, DIN EN ISO 6789

- Accuracy:
 - Torque: $\pm 3\%$ between 20% and 100% wrench capacity.
 - Angle: $\pm 2^\circ$.
- Measuring mode: peak or follower.
- Cycle counter.
- Locking keypad (the operator has access only to program choices and result memorising).
- Measuring unit: N.m, lbf.ft, lbf.in, kg.cm and deg.
- Presetting possible of 9 torque and/or angle values.
- Memory 50 values.
- Supplied in plastic case with calibration certificate.

	L [mm]	Capacity [N.m]	Resolution	$\Delta\Delta$ [g]
E.506-135S	80	6,7 - 135,0	0,1	268
E.506-200S	80	10 - 200	0,1	268
E.506-340S	80	17 - 340	0,1	268

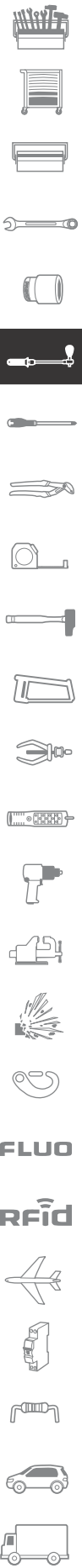

RELEASE TYPE TORQUE DRIVERS



An accurate, durable low-torque tool

A.300MT series

Reliable, high performance

- Reliability of mechanism tested over more than 50,000 operations.
- Accuracy exceeds ISO 6789 specified performance of $\pm 6\%$.
- Automatic reset every 120°.



A.400 series

Safe

- Automatically releases upon reaching the specified torque, impossible to exceed the set value.
- Protected adjustment system: no risk of accidentally altering settings.
- Flattened profile prevents tool rolling on the work-top.

Ergonomic

- Clear, easy to read vernier.
- Ergonomic handle providing an excellent grip.
- Lightweight.

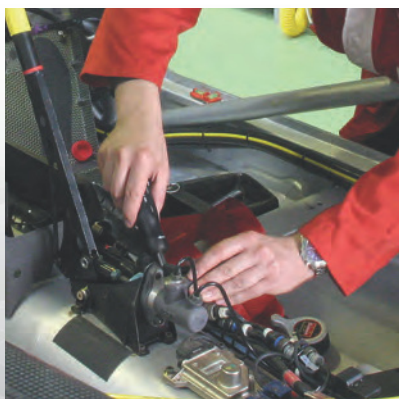

ISO 6789 Type II - CLASS D - CLASS F

RELEASE TYPE TORQUE DRIVER

RELEASE TYPE TORQUE DRIVER

A.MT - Micro-Tech® "low torque" screwdriver

NF EN ISO 6789, ISO 6789, DIN EN ISO 6789

- Lightweight and compact screwdriver for low torque load.
- Right-hand torquing.
- Female hex output for use with bits series 0 - 4 mm (1/4" output with ECR.O drive optional).
- Hex key Adjustment .
- Supplied with calibration certificate and adjustment key.



ED	d [mm]	L [mm]	Capacity [cN.m]	Bits	Graduation	Graduation [Cn.m]	ΔΔ [g]
A.300MT	21	96,5	4 - 20	0	0,05	0,05	75
A.301MT	23	130,0	15 - 75	1	0,50	0,5	130

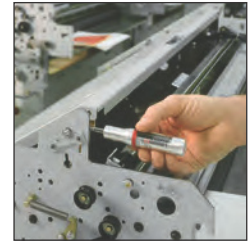
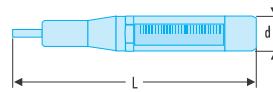

A.MTJ1 - Micro-Tech® torque screwdriver sets

NF EN ISO 6789, ISO 6789, DIN EN ISO 6789

- Lightweight and compact screwdriver for low torque load.
- Right-hand torquing.
- Female hex output for use with bits series 0 - 4 mm (1/4" output with ECR.O drive optional).
- Bits series 0 drive 4 mm.
- Adjustment key 4 mm.
- Supplied in case with calibration certificate.



ED	Capacity [cN.m]	Bits	Screwdriver	ΔΔ [g]
A.300MTJ1	4 - 20	Slotted head: 1,8 - 2,5, PH 0,9 - 1,3 - 1,5 - 2 mm, PZ 0 - 1 - 2 mm	A.300MT	300
A.301MTJ1	15 - 75	Slotted head: 4 - 4,5 - 5,5, PH 1,5 - 2,5 - 3 mm, PZ 0 - 1 mm	A.301MT	370

A.400 - Screwdriver with vernier adjustment

NF EN ISO 6789, ISO 6789, DIN EN ISO 6789

- Class II type D (A.400 maintenance).
- One-direction screwdriver, right-hand torquing.
- Female hex output for use with 1/4" bit.
- ECR drive 1/4" - 1/4" for sockets and accessories optional.
- 1/4" drive on the handle for use with a ratchet handle type A.300PA.
- Hex key Adjustment .
- Supplied with calibration certificate, adjustment key and individual identification number.



ED	L [mm]	Torque N.m	Graduation [N.m]	ΔΔ [g]
A.402	147	0,5 - 2,5	0,1	280
A.404	147	2 - 10	0,5	400



■ A.J2 - Torque screwdriver sets



NF EN ISO 6789, ISO 6789, DIN EN ISO 6789

- Class II type D (A.400 maintenance).
- One-direction screwdriver, right-hand torquing.
- Female hex output for use with bits series 1 - 1/4".
- 1/4" drive on the handle for use with a ratchet handle type A.300PA.
- Ratchet handle (A.300PA).
- Adjustment key 4 mm.
- Supplied in case with calibration certificate and individual identification number.



	Box	Wrench	Bits	Tray	Knob	Bit holder	Screwdriver	ΔΔ [g]
A.402J2	BP.102	A.402-20	Slotted head: 4,5 - 6,5 - 8, Hexagon: 3 - 4 - 5 mm, PZ: 1 - 2 - 3 mm	PL.436	A.300PA	EF.1P4	A.402	700
A.404J2	BP.102	A.404-20	Slotted head: 4,5 - 6,5 - 8, Hexagon: 3 - 4 - 5 mm, PZ: 1 - 2 - 3 mm	PL.435	A.300PA	EF.1PA	A.404	830

■ A.J1 - Torque screwdriver sets - 1/4" sockets



NF EN ISO 6789, ISO 6789, DIN EN ISO 6789

- Class II type D (A.400 maintenance).
- One-direction screwdriver, right-hand torquing.
- Female hex output for use with 1/4" bit.
- 1/4" drive on the handle for use with a ratchet handle type A.300PA.
- Ratchet handle A.300PA.
- ECR drive 1/4" - 1/4" for sockets and accessories.
- Extensions 1/4" (R.210 and R.215).
- Adjustment key 4 mm.
- Supplied in case with calibration certificate and individual identification number.



	Box	Wrench	Socket	Tray	Knob	Screwdriver	ΔΔ [kg]
A.402J1	BP.115	A402 - 20	R.3,2 - 4,0 - 5,0 - 5,5 - 6,0 - 7,0 - 8,0 - 9,0 - 10,0 mm	PL.434	A.300PA	A.402	1,10
A.404J1	BP.115	A404 - 20	R.3,2 - 4,0 - 5,0 - 5,5 - 6,0 - 7,0 - 8,0 - 9,0 - 10,0 mm	PL.433	A.300PA	A.404	1,20

■ Ratchet handle for torque screwdrivers



- Adapting ratchet handle: increased tightening power for repeating or high torque tightening.
- For torque screwdrivers capacity 0.50 --> 10 N.m.
- Max torque: 30 N.m.



	ΔΔ [g]
A.300PA	85

■ Drive socket adapter



- Bit to use 1/4" sockets with the torque screwdrivers A.300MT - A.340MT.
- 6-point drive 4 mm.

	L [mm]	ΔΔ [g]
ECR.0	22	7

■ Socket adapter - 1/4"



NF ISO 1173, ISO 1173

- Bit to use 1/4" sockets with the torque screwdrivers A.400 - A.440 - A.301MT - A.341MT.

	L [mm]	ΔΔ [g]
ECR	25	15

"NON VERNIER" RELEASE TYPE TORQUE DRIVER

A.440 AND A.340MT SERIES NON-VERNIER DRIVERS



Drivers designed for production applications

Same characteristics as A.400 and A.300MT

- Non-vernier adjustment, torque set with a torque-meter.
- Performance exceeds ISO 6789 requirements ($\pm 6\%$ of the preset value).
- Handle release when required torque is reached, prevents inadvertent overtorquing.
- Automatic reset every 120°.

ISO 6789 Type II - CLASS D - CLASS F

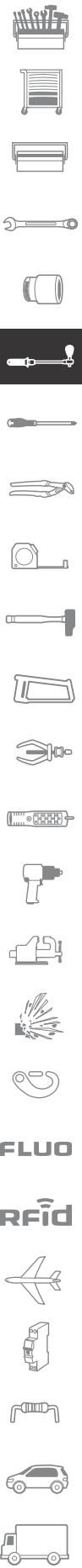

■ A.MT - Micro-Tech® "Production" torque screwdriver

- Screwdriver without vernier: this non graduated screwdriver is adjusted on a control bench.
- Lightweight and compact screwdriver designed specifically for low torque loads.
- One-direction screwdriver, right-hand torquing.
- Female hex output for use with 4 mm bits (1/4" output with ECR.0 drive optional).
- Supplied with adjustment key 4 mm.
- Supplied with calibration certificate and individual identification number.

	d [mm]	L [mm]	Capacity [cN.m]	Capacity [lbf.in]	Series Bits	Outer Size	$\Delta\Delta$ [g]
A.340MT	21	96,5	4 - 20	0,35 - 1,70	0	4 mm	75
A.341MT	23	130,0	15 - 75	1,30 - 6,50	1	1/4"	130

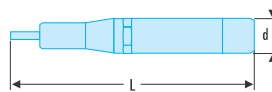

■ A.440 - Micro-Tech® "Production" torque screwdriver

NF EN ISO 6789, ISO 6789, DIN EN ISO 6789

- Class II type F (A.440 production).
- Screwdriver without vernier: this non graduated screwdriver is adjusted on a control bench.
- One-direction screwdriver, right-hand torquing.
- Female hex output for use with bits series 1 - 1/4".
- 1/4" drive on the handle for use with a ratchet handle type A.300PA.
- Supplied with adjustment key 4 mm.
- Supplied with calibration certificate and individual identification number.

	L [mm]	Torque N.m	$\Delta\Delta$ [g]
A.442	147	0,5 - 2,5	300
A.444	168	2 - 10	400



ELECTRONIC TORQUE SCREWDRIVERS

ELECTRONIC SCREWDRIVER SERIES E.S400



High precision for low torque

This new product offers the high precision and ease of use you'd expect from the FACOM brand. With its traceability functions, it is an ideal tool for maintenance in sectors such as aeronautics, medical, nuclear...

High performance

- Has a 2% accuracy, between 20% and 100% capacity, much higher than mechanical screwdrivers and the ISO 6789 standard (6% for torque screwdrivers).
- Electronic measure: high repeatability and no wear effect.

Easy use

- 9 pre-adjustable torque values.
- Measurement units available: cNm, in.lb, kg.cm.
- Sound and visual alarm once the torque is reached.
- Ergonomic: Protwist grip and bit autolocking system.

Traceability

- Tightening torques are transmitted through the USB cable.
- 250 torque value memory.

■ E.S400 - Torque reading electronic torque screwdrivers



NF EN ISO 6789, ISO 6789, DIN EN ISO 6789

- Accuracy: $\pm 2\%$ clockwise ($\pm 3\%$ counter clockwise) between 20% and 100% screwdriver capacity.
- Resolution: 0.1 cN.m.
- Measurement mode: tip or follower.
- 1/4" outlet with auto-locking system for series 1 and series 6 bits.
- Measurement unit: cN.m, in.lb, Kg.cm .
- 9 torque presets available.
- Memory 250 values with PC USB link.
- Locking keypad (program selection and result log only accessible to the operator).
- Hole in the handle for strapping when working in high places.
- Supplied with 1 AAA-LR03 1.5V battery.
- Supplied with an ISO6789 calibration certificate.
- Supplied in plastic case and foam module, dim. (L.xW.xH.): 570x100x70 mm.
- USB cable E.S404-USB and plugs E.S404-KIT set available as spares.



	L [mm]	Capacity [N.m]	$\Delta\Delta$ [g]
E.S401	215	0,1 - 1	630
E.S404	215	0,4 - 4	630

■ E.S400J1 - Electronic torque screwdriver sets - screwing bits



NF EN ISO 6789, ISO 6789, DIN EN ISO 6789

- Accuracy: $\pm 2\%$ clockwise ($\pm 3\%$ counter clockwise) between 20% and 100% screwdriver capacity.
- Resolution: 0.1 cN.m.
- Measurement mode: tip or follower.
- 1/4" outlet with auto-locking system for series 1 and series 6 bits.
- Measurement unit: cN.m, in.lb, Kg.cm .
- Presetting possible of 9 torque values.
- Memory 250 values with PC USB link.
- Locking keypad (program selection and result log only accessible to the operator).
- Hole in the handle for strapping when working in high places.
- Supplied with 1 AAA-LR03 1.5V battery.
- Supplied with an ISO6789 calibration certificate.
- Screwdriver length 215 mm.
- 6 series 6 bits with 1/4" groove - length 50 mm: slotted head 3 - 4 - 5.5 and Phillips® High Perf® 1 - 2 - 3.
- Supplied in plastic case and foam module, dim. (L.xW.xH.): 570x100x70 mm.
- USB cable E.S404-USB and plugs E.S404-KIT set available as spares.



	L [mm]	Capacity [N.m]	Screwdriver	$\Delta\Delta$ [kg]
E.S401J1	570	0,1 - 1	E.S401	1.2
E.S404J1	570	0,4 - 4	E.S404	1.2

TORQUE ACCESSORIES

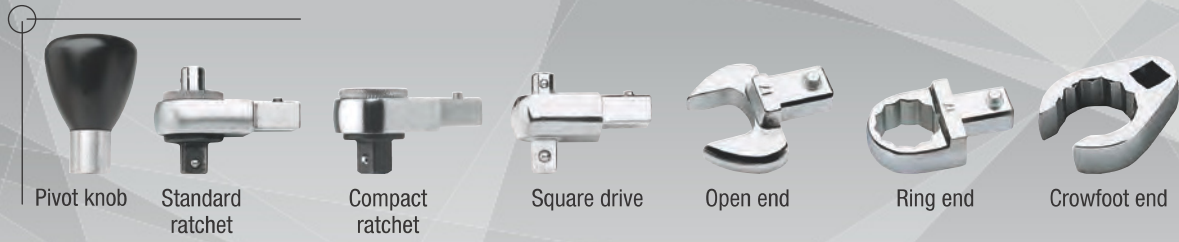

7 TYPES OF ACCESSORY



Wrench fitted with a ratchet J.372, a knob S.305P and a socket.

3 types of end fitting:

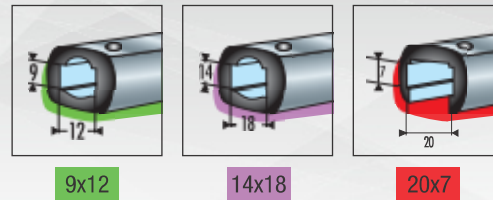

1. CHOOSE YOUR WRENCH OR DRIVER

306	208	200	203
R.304DA R.306-25D J.306-50D S.306-100D R.306U J.306U	J.208-50D S.208-100D		
S.306-200D S.306-350D S.306U K.306-600D	J.208-200D S.208-340D		
K.306-1000D		K.200DB K.202DB M.200DB	
S.306-100R S.306-200R S.306-350R			R.203DA J.203DA S.203A
E.306	E.316	248	446
E.306-30D E.306-135D	E.316-30D E.316-135D	R.344DA R.248-25D J.248-50D S.248-100D	R.446-25
E.306-200D E.306-340D	E.316-200D E.316-340D	S.248-200D S.248-340D	J.446-50 S.446-100
		A.400 A.300MT	A.440 A.340MT
		A.402 A.404	A.442 A.444
		A.300MT A.301MT	A.340MT A.341MT

2. CHOOSE THE TYPE OF ACCESSORY

9x12	J.372 S.372	R.372 J.372V S.372V	R.373 J.373 S.373	Series 10	Series 12	
14x18	S.382	S.382V K.382A	S.383 K.383	Series 11	Series 13	
Ø 30		K.151B M.151	M.151			
20x7		J.152 S.152	J.203E S.203E	Series 20		
9x12	J.372 S.372	R.372 J.372V S.372V	R.373 J.373 S.373	Series 10	Series 12	
14x18	S.382	S.382V K.382A	S.383 K.383	Series 11	Series 13	
20 x 7		J.152 S.152	J.203E S.203E	Series 20		
Ø 1/4	ECR					
Ø 4		ECRO				

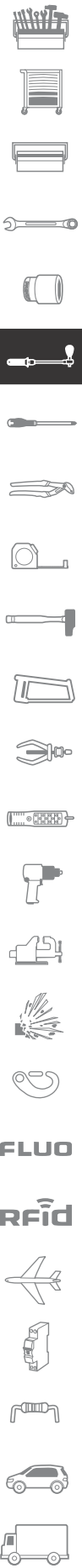

ACCESSORIES 9 X 12 MM

SAFETY OF END FITTINGS

When the wrench releases, the torque accessories are subjected to severe shocks that can cause them to fail after a certain number of cycles.

The diagram below shows the number of cycles not to be exceeded according to the applied torque. The accessory must be replaced before reaching the maximum number of cycles.

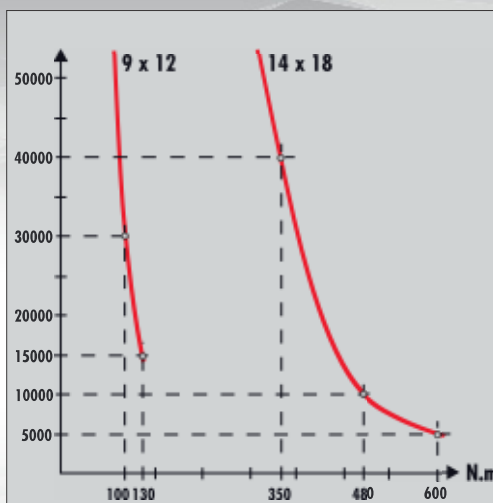

Ratchets - drive 9 x 12 mm

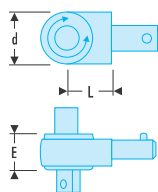

• For use with pivot handle S.305P.



Model	d [mm]	E [mm]	L [mm]	Square ["]	ΔΔ [g]
J.372	37	26	15	3/8	155
S.372	37	26	15	1/2	165

Compact ratchets - drive 9 x 12 mm

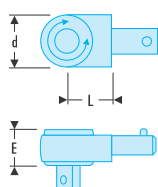

Model	d [mm]	E [mm]	L [mm]	Square ["]	ΔΔ [g]
R.372	27	19	15	1/4	70
J.372V	37	26	15	3/8	140
S.372V	37	26	15	1/2	150

Square drive - drive 9 x 12 mm

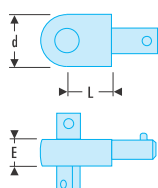

• For use with pivot handle S.305P, except the R.373 model.



Model	d [mm]	E [mm]	L [mm]	Square ["]	ΔΔ [g]
R.373	23	14	15	1/4	55
J.373	26	17	15	3/8	85
S.373	26	17	15	1/2	100

▪ Metric open end bits - drive 9 x 12 mm

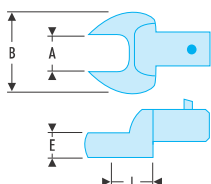

Size	A [mm]	B [mm]	E [mm]	L [mm]	ΔΔ [g]
10.7	7	21,0	5	17,5	33
10.8	8	22,0	5	17,5	32
10.9	9	23,5	6	17,5	38
10.10	10	24,5	6	17,5	37
10.11	11	26,0	6	17,5	36
10.12	12	27,5	7	17,5	44
10.13	13	29,0	7	17,5	45
10.14	14	31,5	7	20,0	42
10.15	15	33,0	9	20,0	61
10.16	16	35,5	9	20,0	60
10.17	17	37,5	9	20,0	62
10.18	18	39,0	9	20,0	69
10.19	19	41,5	9	20,0	67

▪ Inch open end bits - drive 9 x 12 mm

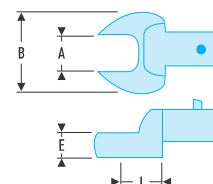

Size	A ["]	B [mm]	E [mm]	L [mm]	ΔΔ [g]
10.1/4	1/4	19	5	17,5	33
10.5/16	5/16	19	5	17,5	26
10.3/8	3/8	25	6	17,5	38
10.7/16	7/16	25	6	17,5	36
10.1/2	1/2	31	7	17,5	43
10.9/16	9/16	31	7	20,0	41
10.5/8	5/8	37	9	20,0	60
10.11/16	11/16	37	9	20,0	59
10.3/4	3/4	40	9	20,0	69

▪ Polygon drives - drive 9 x 12 mm

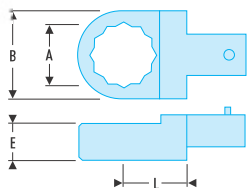

Size	A [mm]	B [mm]	E [mm]	L [mm]	ΔΔ [g]
12.7	7	20	7,9	17,5	33
12.8	8	20	7,9	17,5	33
12.9	9	20	7,9	17,5	32
12.10	10	20	7,9	17,5	36
12.11	11	20	7,9	17,5	34
12.12	12	20	12,1	17,5	41
12.13	13	20	12,1	17,5	40
12.14	14	23,5	12,1	17,5	49
12.15	15	24,5	12,1	17,5	46
12.16	16	26,5	12,9	17,5	54
12.17	17	27,5	13,1	17,5	50
12.18	18	30	13,1	17,5	57
12.19	19	31	13,1	17,5	67

▪ 12 - Inch ring ends - 9 x 12 mm end fitting

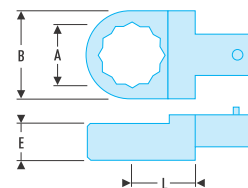

- Straight ring ends, 3/8" drive.
- Allows use in confined spaces.
- 9 dimensions available.

Size	A ["]	B [mm]	E [mm]	L [mm]
12.1/4	1/4	20	7,9	17,5
12.5/16	5/16	20	7,9	17,5
12.3/8	3/8	20	7,9	17,5
12.7/16	7/16	20	7,9	17,5
12.1/2	1/2	20	12,1	17,5
12.9/16	9/16	23,5	12,1	17,5
12.5/8	5/8	26,5	12,9	17,5
12.11/16	11/16	30	13,1	17,5
12.3/4	3/4	31	13,1	17,5



ACCESSORIES 14 X 18 MM

▪ Ratchet - drive 14 x 18 mm

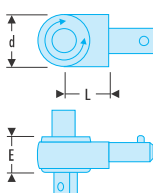

- For use with swivel handle S.305P.
- Square: 1/2".

Model	d [mm]	E [mm]	L [mm]	Square ["]	ΔΔ [g]
S.382	41	26	27	1/2	300

▪ Compact ratchets - drive 14 x 18 mm

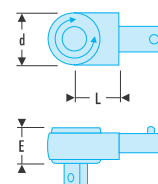

Model	d [mm]	E [mm]	L [mm]	Square ["]	ΔΔ [g]
S.382V	41	26	27	1/2	285
K.382A	69	35	27	3/4	870

▪ Square drive - drive 14 x 18 mm

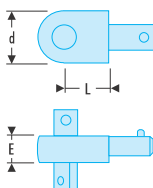

- For use with pivot handle S.305P, except the K.383 model.

Model	d [mm]	E [mm]	L [mm]	Square ["]	ΔΔ [g]
S.383	32	22	27	1/2	160
K.383	38	22	27	3/4	340



▪ Metric open end bits - drive 14 x 18 mm

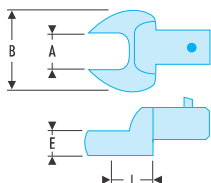

Code	A [mm]	B [mm]	E [mm]	L [mm]	ΔΔ [g]
11.13	13	34	8	25,0	114
11.14	14	34	8	25,0	113
11.15	15	34	8	25,0	111
11.16	16	39	10	25,0	140
11.17	17	39	12	25,0	134
11.18	18	39	12	25,0	136
11.19	19	45	12	25,0	140
11.21	21	45	12	25,0	157
11.22	22	52	14	25,0	161
11.23	23	52	14	25,0	172
11.24	24	52	14	25,0	165
11.27	27	59	16	32,5	222
11.30	30	64	18	32,5	277
11.32	32	64	18	32,5	269

▪ Inch open end bits - drive 14 x 18 mm

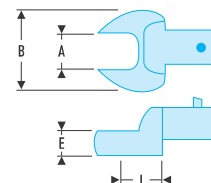

Code	A ["]	B [mm]	E [mm]	L [mm]	ΔΔ [g]
11.1/2	1/2	34	8	25,0	114
11.9/16	9/16	34	8	25,0	111
11.5/8	5/8	39	10	25,0	140
11.11/16	11/16	39	12	25,0	137
11.3/4	3/4	45	12	25,0	156
11.13/16	13/16	45	12	25,0	152
11.7/8	7/8	52	14	25,0	172
11.15/16	15/16	52	14	25,0	167
11.1"1/4	1"1/4	59	16	32,5	266
11.1"1/16	1"1/16	64	18	32,5	221

▪ Polygon drives - drive 14 x 18 mm

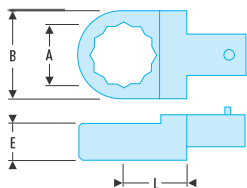

Code	A [mm]	d [mm]	E [mm]	L [mm]	ΔΔ [g]
13.13	13	30,0	11	25	113
13.14	14	30,0	11	25	109
13.15	15	30,0	11	25	107
13.16	16	30,0	11	25	127
13.17	17	30,0	12	25	123
13.18	18	30,0	12	25	118
13.19	19	31,0	12	25	141
13.21	21	33,0	12	25	133
13.22	22	35,0	14	25	153
13.23	23	38,0	14	25	157
13.24	24	38,0	14	25	143
13.27	27	41,5	16	31	183
13.30	30	45,0	18	31	223
13.32	32	47,5	18	31	209
13.34	34	51,0	11	31	212
13.36	36	53,0	19	31	193

▪ 13 - Inch polygon bits - drive 14x18

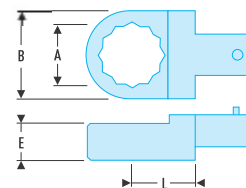

ASME B107.100

- Polygon bits drive 14x18.
- Inch sizes: from 1/2 to 1P1/16.

Code	A ["]	B [mm]	E [mm]	L [mm]	ΔΔ [g]
13.1/2	1/2	30	21,5	60,9	126
13.9/16	9/16	30	21,5	61,4	128
13.5/8	5/8	30	21,5	62,9	134
13.11/16	11/16	30	21,5	63,9	138
13.3/4	3/4	31	21,5	65,4	142
13.13/16	13/16	33	21,5	66,4	150
13.7/8	7/8	35	21,5	67,4	152
13.15/16	15/16	38	21,5	68,4	180
13.1P1/16	1P1/16	41,5	21,5	76,6	204



ACCESSORIES 20 X 7 MM

Swivel handles - drive 20 x 7 mm



- Allows to maintain the wrench parallel with the tightening plane and contribute to tightening accuracy.
- Used with square bits Ref J.203E - S.203E and torque wrench ref. R.203 DA.



Ref	d [mm]	L [mm]	Wrench	For use on	ΔΔ [g]
R.200P	22	45	R.203DA	R.203DA	20
S.200P	36	55	J.203E - S.203E	J.203E, S.203E	55

Ratchets - drive 20 x 7 mm

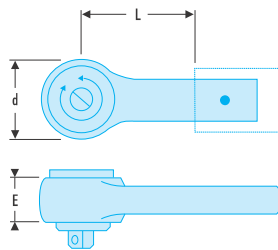

- 5° increment.
- For use on torque wrenches ref. J.203DA - S.203DA - S.306-100R - S.306-200R - S.306-350R.



Ref	d [mm]	E [mm]	L [mm]	Square ["]	Wrench	ΔΔ [g]
J.152	38	25	55	3/8	J.203DA	274
S.152	38	25	55	1/2	S.203DA - S.306-100R - S.306-350R - S.306-200R	275

Square drive - drive 20 x 7 mm

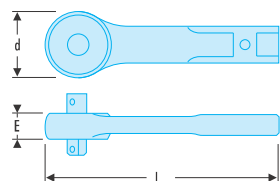

- For use on torque wrenches ref. J.203DA - S.203DA - S.306-100R - S.306-200R - S.306-350R.



Ref	d [mm]	E [mm]	L [mm]	Square ["]	ΔΔ [g]
J.203E	25	11	56	3/8	140
S.203E	25	11	56	1/2	150

Adapters - drive 20 x 7 mm



- For use with:
 - bits 9 x 12 mm on wrenches max capacity 100 N.m.
 - bits 14 x 18 mm on wrenches max capacity 600 N.m.



Ref	Attachment	ΔΔ [g]
J.274	9 x 12	135
S.284	14 x 18	145

Open end bits - drive 20 x 7 mm

- For use on torque wrenches series 203, 306R and 446.

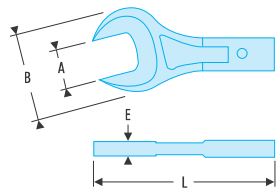

Ref	A [mm]	B [mm]	E [mm]	L [mm]	ΔΔ [g]
20.10	10	24	6,0	105	60
20.11	11	24	6,0	105	60
20.12	12	29	6,0	106	60
20.13	13	29	6,0	106	60
20.14	14	29	6,0	106	65
20.15	15	40	7,5	109	105
20.16	16	40	7,5	109	105
20.17	17	40	7,5	109	105
20.18	18	40	7,5	109	100

Ref	A [mm]	B [mm]	E [mm]	L [mm]	ΔΔ [g]
20.19	19	40	7,5	109	100
20.21	21	53	8,0	112	145
20.22	22	53	8,0	112	145
20.23	23	53	8,0	112	145
20.24	24	53	8,0	112	140
20.27	27	66	9,0	115	185
20.30	30	66	9,0	115	185
20.32	32	66	9,0	115	180
20.36	36	74	10,0	118	220

CROWFOOT ACCESSORIES

Swivel handle

- Allows to maintain the wrench parallel with the tightening plane.
- Use with 3/8" and 1/2" ratchets and drive squares.
- Max diam. size: 45 mm.



Ref	L [mm]	ΔΔ [g]
S.305P	66	110

14 - Welding tip

- Welding a tool onto a weld-on tip modifies the centre distance between the tool centre and the wrench. This modification changes the torque value required. Therefore, a torque controller must be used to recalibrate the torque wrench (E.2000).
- Presentation: black finish.
- Hardness: 46-50 HRc.



Ref	A [mm]	B [mm]	C [mm]	L [mm]	L1 [mm]
14.9X12	9x12	14,7	17,4	24,5	16,5
14.14X18	14x18	22	26,3	36,5	24,5



FLUO

Rfid



CROWFOOT ACCESSORIES

■ J.SPR - 3/8" metric Crowfoot Accessories



AS954

For use on interchangeable head torque wrenches

➤	A [mm]	B [mm]	E [mm]	E1 [mm]	L [mm]	L1 [mm]	ΔΔ [g]
J.7SPR	7	9.4	5.5	11.1	64.9	50.8	24
J.8SPR	8	10.7	5.5	11.1	65.5	50.8	26
J.9SPR	9	12.4	6.5	11.1	66.4	50.8	28
J.10SPR	10	12.4	6.5	11.1	66.4	50.8	30
J.12SPR	12	14.5	7.0	11.1	67.4	50.8	34
J.14SPR	14	16.6	7.9	11.1	68.5	50.8	36
J.16SPR	16	18.7	8.7	11.1	69.5	50.8	38
J.18SPR	18	20.5	9.5	11.1	70.5	50.8	40
J.20SPR	20	23.0	10.3	11.1	71.5	50.8	44

■ J.R - 3/8" inch Crowfoot Accessories



AS954

For use on interchangeable head torque wrenches

➤	A ["]	B [mm]	E [mm]	E1 [mm]	L [mm]	L1 [mm]	ΔΔ [g]
J.1/4R	1/4	10.7	5.5	11.1	65.5	50.8	28
J.5/16R	5/16	12.4	6.5	11.1	66.4	50.8	30
J.3/8R	3/8	14.5	7.1	11.1	67.4	50.8	36
J.7/16R	7/16	16.6	7.9	11.1	68.5	50.8	38
J.1/2R	1/2	18.7	8.7	11.1	69.5	50.8	42
J.9/16R	9/16	20.5	9.5	11.1	70.5	50.8	44
J.5/8R	5/8	23.0	10.3	11.1	71.5	50.8	46

■ R.FLA - 1/4" inch crowfoot box end bits



ASME B107.100

- Thin wall 12-point head.
- Max torque recommended: 8.5 N.m.
- Built to aeronautical specifications.
- Inch sizes: from 1/4" to 3/8".
- Bright chrome finish.

➤	A ["]	B [mm]	C [mm]	E [mm]	L1 [mm]	ΔΔ [g]
R.1/4FLA	1/4	11.9	4.5	5.9	36.3	13
R.5/16FLA	5/16	13.3	5.8	5.9	36.8	12.5
R.3/8FLA	3/8	15.7	7	5.9	38	14

■ R.CF - 1/4" metric crowfoot end bits



ASME B107.100

- Anti-slip design ensuring proper fitting on the fastener.
- Shaped to distribute the contact force over a larger surface.
- Suitable for use in confined spaces.
- Adapted to low torque uses.
- Sizes in mm: from 7 to 14
- Bright chrome finish.

➤	A [mm]	E [mm]	L [mm]	L1 [mm]	ΔΔ [g]
R.7CF	7	5.5	23.6	13.2	9
R.8CF	8	5.5	24.9	16.5	9
R.9CF	9	5.5	25.9	18.3	11
R.10CF	10	5.5	26.8	19.6	14
R.11CF	11	5.5	28.7	22.1	18
R.12CF	12	5.5	29.8	25.4	23
R.13CF	13	5.5	30.3	26.2	25
R.14CF	14	5.5	32.3	27.9	27

■ J.CF - 3/8" inch crowfoot open end bits



ASME B107.100

- Anti-slip design ensuring proper fitting on the fastener.
- Shaped to distribute the contact force over a larger surface.
- Suitable for use in confined spaces.
- Adapted to low torque uses.
- Inch sizes: from 3/8" to 3".
- Bright chrome finish.

➤	A ["]	E [mm]	L [mm]	L1 [mm]	ΔΔ [g]
J.3/8CF	3/8	8	32.3	23.4	27
J.7/16CF	7/16	8	33.1	23.4	29
J.1/2CF	1/2	8	35.8	27.9	32
J.9/16CF	9/16	8	40	31.5	35
J.5/8CF	5/8	8	42.1	34.3	41
J.11/16CF	11/16	8	47.5	39.1	45
J.3/4CF	3/4	8	48.5	40.4	50
J.13/16CF	13/16	8	50	43.7	52
J.7/8CF	7/8	8	51.3	45.2	54
J.15/16CF	15/16	8	52.8	45.7	59
J.1PCF	1P	8	54.1	50.8	70
J.1P1/16CF	1P1/16	8	55.3	53.1	109
J.1P1/8CF	1P1/8	8	56	53.1	115
J.1P3/16CF	1P3/16	8	57.6	53.8	120
J.1P1/4CF	1P1/4	8	59.5	54.6	122
J.1P5/16CF	1P5/16	8	61.9	54.6	125
J.1P3/8CF	1P3/8	8	63.4	61	131
J.1P7/16CF	1P7/16	8	65.3	61	135
J.1P1/2CF	1P1/2	8	67.8	65.8	150
J.1P9/16CF	1P9/16	8	69.3	65.8	154
J.1P5/8CF	1P5/8	8	71.2	69.1	163
J.1P11/16CF	1P11/16	8	73.6	69.1	172
J.1P3/4CF	1P3/4	8	74.5	73.7	177
J.1P13/16CF	1P13/16	8	76.9	73.7	181
J.1P7/8CF	1P7/8	8	77.9	81.3	204
J.1P15/16CF	1P15/16	8	81.1	84.8	222
J.2PCF	2P	11.1	85.2	88.1	322
J.2P1/16CF	2P1/16	11.1	86.8	88.1	331
J.2P1/8CF	2P1/8	11.1	90	91.2	336
J.2P3/16CF	2P3/16	11.1	91.7	92.7	354
J.2P1/4CF	2P1/4	11.1	93.3	99.1	404
J.2P5/16CF	2P5/16	11.1	95	100.8	408
J.2P3/8CF	2P3/8	11.1	99.6	105.4	458
J.2P7/16CF	2P7/16	11.1	103.7	105.4	467
J.2P1/2CF	2P1/2	11.1	106.9	108.7	499
J.2P9/16CF	2P9/16	11.1	108.5	110.2	503
J.2P5/8CF	2P5/8	11.1	112.5	116.6	576
J.2P11/16CF	2P11/16	11.1	114.5	119.9	608
J.2P3/4CF	2P3/4	11.1	117.6	121.4	621
J.2P13/16CF	2P13/16	11.1	121.5	121.4	626
J.2P7/8CF	2P7/8	11.1	123.3	129.3	689
J.2P15/16CF	2P15/16	11.1	124.9	130.8	703
J.3PCF	3P	11.1	125.7	130.8	717

■ R.CF - 1/4" inch crowfoot open end bits



ASME B107.100

- Anti-slip design ensuring proper fitting on the fastener.
- Shaped to distribute the contact force over a larger surface.
- Suitable for use in confined spaces.
- Adapted to low torque uses.
- Inch sizes: from 1/4" to 9/16".
- Bright chrome finish.

➤	A ["]	E [mm]	L [mm]	L1 [mm]	ΔΔ [g]
R.1/4CF	1/4	5.5	23.1	13.5	9
R.5/16CF	5/16	5.5	24.8	16.5	14
R.3/8CF	3/8	5.5	26.4	19.8	16
R.7/16CF	7/16	5.5	28	22.1	18
R.1/2CF	1/2	5.5	29.6	26.2	23
R.9/16CF	9/16	5.5	31.2	28.4	25

■ J.CF - 3/8" metric crowfoot open end bits



ASME B107.100

- Anti-slip design ensuring proper fitting on the fastener.
- Shaped to distribute the contact force over a larger surface.
- Suitable for use in confined spaces.
- Adapted to low torque uses.
- Sizes in mm: from 8 to 32
- Bright chrome finish.

➤	A [mm]	E [mm]	L [mm]	L1 [mm]	ΔΔ [g]
J.8CF	8	8	33.8	22.9	20
J.9CF	9	8	33.6	22.9	22
J.10CF	10	8	34.2	23.6	25
J.11CF	11	8	34.8	23.6	32
J.12CF	12	8	37.4	27.9	35
J.13CF	13	8	37.9	27.9	37
J.14CF	14	8	38.5	30	40
J.15CF	15	8	41.1	34.3	45
J.16CF	16	8	42.2	34.3	49
J.17CF	17	8	43.6	35.8	54
J.18CF	18	8	48.9	40.9	59
J.19CF	19	8	49.5	40.9	61
J.20CF	20	8	52.5	40.9	63
J.21CF	21	8	53.4	43.9	65
J.22CF	22	8	56.3	43.9	68
J.23CF	23	8	59.4	51.3	75
J.24CF	24	8	60.7	51.3	80
J.27CF	27	8	59.8	51.3	90
J.30CF	30	8	62.4	54	100
J.32CF	32	8	61.8	54	110



FLUO

Rfid



CROWFOOT ACCESSORIES

▪ J.FL - 3/8" inch crowfoot box end bits



ASME B107.100

- Thin wall 12-point high head for better accessibility.
- Adapted to use in confined spaces inaccessible to ratchets and other wrenches.
- The hole in the drive bit secures the bit during use.
- Built to aeronautical specifications.
- Dimensions in inches: 5/8 to 1P1/16.
- Bright chrome finish.

Part No.	A ["]	B [mm]	C [mm]	L [mm]	ΔΔ [g]
J.5/8FL	5/8	24.6	18.3	38	40
J.11/16FL	11/16	27	18.3	41	46
J.3/4FL	3/4	29.4	19.1	43	54
J.13/16FL	13/16	31.4	19.1	45	58
J.7/8FL	7/8	33.7	19.8	48	68
J.15/16FL	15/16	35.7	19.8	49	72
J.1PFL	1P	37.7	20.6	51	74
J.1P1/16FL	1P1/16	39.7	20.6	53	83

▪ Case of 9 x 12 mm metric-size open end bits



Includes:

- 11 x 9x12 mm metric-size open end bits: 10.8 - 10 - 11 - 12 - 13 - 14 - 15 - 16 - 17 - 18 - 19 .
- Foam tray: PM.10J11.
- Empty case: BP.115.

Part No.	L [mm]	ΔΔ [g]
10.J11	330	980

▪ Case of 9 x 12 mm inch-size open end bits



Includes:

- 9 x 9x12 mm inch-size open end bits: 10.1/4 - 5/16 - 3/8 - 7/16 - 1/2 - 9/16 - 5/8 - 11/16 - 3/4.
- Foam tray: PM.10J9U.
- Empty case: BP.115.

Part No.	L [mm]	ΔΔ [g]
10.J9U	335	866

▪ Case of 14 x 18 mm metric-size open end bits



Includes:

- 11 x 9x12 mm metric-size open end bits: 11.13 - 14 - 15 - 16 - 17 - 18 - 19 - 21 - 22 - 23 - 24 .
- Foam tray: PM.11J11.
- Empty case: BP.109.

Part No.	L [mm]	ΔΔ [kg]
11.J11	480	2.5

Case of 14 x 18 mm inch-size open end bits



Includes:

- 8 x 9x12 mm inch-size open end bits: 11.1/2 - 9/16 - 5/8 - 11/16 - 3/4 - 13/16 - 7/8 - 15/16.
- Foam tray: PM.11J8U.
- Empty case: BP.112.

Image	L [mm]	ΔΔ [kg]
	385	1.6
11.J8U		

Case of 9 x 12 mm metric-size polygon bits



Includes:

- 11 x 9x12 mm metric-size polygon bits: 12.8 - 10 - 11 - 12 - 13 - 14 - 15 - 16 - 17 - 18 - 19 .
- Foam tray: PM.12J11.
- Empty case: BP.115.

Image	L [mm]	ΔΔ [kg]
	330	1.0
12.J11		

Case of 9 x 12 mm inch-size polygon bits



Includes:

- 9 x 9x12 mm inch-size polygon bits: 12.1/4 - 5/16 - 3/8 - 7/16 - 1/2 - 9/16 - 5/8 - 11/16 - 3/4.
- Foam tray: PM.12J9U.
- Empty case: BP.115.

Image	L [mm]	ΔΔ [g]
	335	877
12.J9U		

Case of 14 x 18 mm metric-size polygon bits



Includes:

- 10 x 9x12 mm metric-size polygon bits: 11.14 - 15 - 16 - 17 - 18 - 19 - 21 - 22 - 23 - 24 .
- Foam tray: PM.13J10.
- Empty case: BP.112.

Image	L [mm]	ΔΔ [kg]
	385	1.9
13.J10		



FLUO

RFid



SET OF ACCESSORIES

Case of 14 x 18 mm inch-size polygon bits



- Includes:
- 8 x 9x12 mm inch-size polygon bits: 13.1/2 - 9/16 - 5/8 - 11/16 - 3/4 - 13/16 - 7/8 - 15/16.
 - Foam tray: PM.13J8U.
 - Empty case: BP.112.

	L [mm]	ΔΔ [kg]
13.J8U	385	1.6

Case of 1/4 crowfoot metric-size open end bits



- Includes:
- 8 x 1/4 crowfoot metric-size open end bits: R.7CF - 8CF - 9CF - 10CF - 11CF - 12CF - 13CF - 14CF.
 - Foam tray: PM.RJ8CF.
 - Empty case: BP.102.

	L [mm]	ΔΔ [g]
R.J8CF	200	294

Case of 1/4 crowfoot inch-size open end bits



- Includes:
- 6 x 1/4 crowfoot inch-size open end bits: R.1/4CF - 5/16CF - 3/8CF - 7/16CF - 1/2CF - 9/16CF.
 - Foam tray: PM.RJ6CFU.
 - Empty case: BP.102.

	L [mm]	ΔΔ [g]
R.J6CFU	200	264

Case of 3/8 crowfoot metric-size open end bits



- Includes:
- 14 x 3/8 crowfoot metric-size open end bits: J.10CF - 11CF - 12CF - 13CF - 14CF - 15CF - 16CF - 17CF - 18CF - 19CF - 21CF - 22CF - 23CF - 24CF.
 - Foam tray: PM.JJ14CF.
 - Empty case: BP.112.

	L [mm]	ΔΔ [kg]
J.J14CF	385	1.4

Case of 3/8 crowfoot inch-size open end bits



- Includes:
- 11 x 3/8 crowfoot inch-size open end bits: J.3/8CF - 7/16CF - 1/2CF - 9/16CF - 5/8CF - 11/16CF - 3/4CF - 13/16CF - 7/8CF - 15/16CF - 1PCF.
 - Foam tray: PM.JJ11CFU.
 - Empty case: BP.112.

	L [mm]	ΔΔ [kg]
J.J11CFU	385	1.2

Case of 3/8 piping crowfoot inch-size open end bits



- Includes:
- 8 x 3/8 piping crowfoot inch-size open end bits: J.5/8FL - 11/16FL - 3/4FL - 13/16FL - 7/8FL - 15/16FL - 1PFL - 1P1/16FL.
 - Foam tray: PM.JJ8FLU.
 - Empty case: BP.115.

	L [mm]	ΔΔ [g]
J.J8FLU	335	915

Set of 9 1/4" to spline adaptors



- Includes:
- 11 metric-size open end bits: J.7SPR - 8 - 9 - 10 - 12 - 14 - 16 - 18 - 20.
 - Foam tray: PM.JJ9SPR.
 - Empty case: BP.115.

	L [mm]	ΔΔ [g]
J.J9SPR	327	970

Set of 7 1/4" to spline adaptors



- Includes:
- 7 x 3/8" inch-size open end bits: J.1/4R - 5/16 - 3/8 - 7/16 - 1/2 - 9/16 - 5/8.
 - Foam tray: PM.JJ7RU.
 - Empty case BP.102.

	L [mm]	ΔΔ [g]
J.J7RU	200	280



ANGULAR TIGHTENING WRENCHES

PROTRACTOR ATTACHMENTS



Designed for cylinder-heads

FACOM offers a complete range of specially designed tools.

Maximum visibility

- Choice of tapered drum with reverse laser marking. (DMP.360, DM.360L, D.360L) or flat drum with normal marking. (DM.360, DM.370) Set the drum to the value recommended by the manufacturer and stop at zero.

Easier to attach

- Wide range of drum-locking accessories: Clamp, magnet, 3 limit stops (24, 45 and 65 mm).

Compliance with manufacturer's recommendations

- It is essential to apply the manufacturer's recommended cylinder head torques.
- Tightening to the correct torque with a suitable torque wrench.
- Correct torquing sequence and turn angle.

DM - Angular tightening gauges



- Magnetic attached angle gauge for cylinder heads.
- Allows accurate measurement of angle following tightening with a torque wrench.
- Flat drum with top reading.
- Drum positioning on the value recommended by the manufacturer, then tightening to zero.
- Graduations: 2°.
- Male and female square drive.
- Fixed point by flexible with magnet.

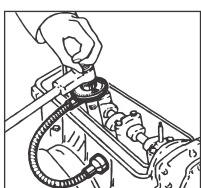

	d [mm]	L [mm]	Square ["]	ΔΔ [g]
DM.360	63	410	1/2	350
DM.370	73	430	3/4	550

TORQUE CONTROLLER

Easy torque control for all!

E.2000

Simple and fast

- Easy to use device with minimum settings to avoid errors.
- For testing wrenches before use.

Safe

- No risk of bad reading by the operator: limit value and tolerance can be preset, indication by orange, green, red LED.
- RS232 output for traceability.



Wide torque range

- 3 devices covering a wide torque range from 2 to 1000 Nm.



■ E.2000 - Torque controllers

- Accuracy: $\pm 1\%$, ± 1 digit.
- Measuring unit: N.m, lbf.ft, lbf.in.
- Measuring mode: monitor, edge and peak.
- Possible presetting of a limit value and tolerance with orange, green, red LED indicator.
- RS232 PC link.
- Dimensions (L x W x H.): 150 x 150 x 90 mm.
- Supplied with a calibration certificate.



Model	L [mm]	Capacity [N.m]	Square	Square ["]	$\Delta\Delta$ [kg]
E.2000-50	150	2 - 50	-	3/8"	2.6
E.2000-350	150	10 - 350	-	1/2"	2.6
E.2000-1000	150	100 - 1000	27	-	4.6

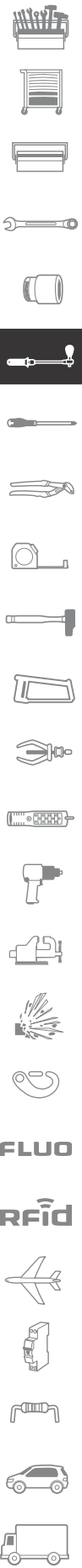

TORQUE CALIBRATION EQUIPMENT

In order to maintain accuracy and correct operation, ISO 6789 requires that all torque tools are calibrated either every 12 months or 5,000 cycles, whichever is sooner.

FACOMs solution allows users to take control : check and manage your fleet of assets with our powerful ISO compliant modular solution for torque calibration that comprises our custom developed software and precision sensors – add the CD.12A bench for ultimate accuracy.

FACOM Calibration Software

- FACOMs unique custom written software allows checking calibration of torque wrenches to ISO 6789.
- Use in manual mode for Peak, Track and Hold checks.
- Guided measure intuitively steps users through a full calibration from check to certification. Either follow the pre-loaded ISO routines or use the drag and drop interface to create a custom procedure to manage your tool database.
- Requires Windows OS, and an E.6000 sensor connected to a USB port.

Download free from www.facom.com



E.6000 Sensors

- USB connected sensors for use with FACOM torque calibration software. Engineered to tight tolerances and individually calibrated, these provide high precision and accuracy to ensure ISO 6789 compliant accuracy < 1% across full range – see table.
- Full range of sensors from 0.04 to 1000Nm
- Our wide range sensor covers from 10-1000Nm in a single unit.

FACOM Calibration Bench

- ISO 6789 calls for wrenches to be held horizontally and the load to be applied within given time constraints. This bench provides accuracy and repeatability when testing and certifying, to ensure a quality "click".
- A 1200:1 ratio gearbox allows precise manual control of the applied torque, allowing users to comply with the speed requirements from ISO6789
- For use with the E.6000 sensors, the CD.12A is robust and durable. The adjustable loading pin ensures positional accuracy, while the 1200:1 gearbox aids precision during load application.



SKU	Description	Range (N.m)		Accuracy	
		LOW	HIGH	1%	0,50%
E.6000-C1000	High range sensor 10 to 1000 Nm	10	1000	10-99	100-1000
E.6000-C400	Sensor 20 to 400 Nm	20	400	20-39	40-400
E.6000-C50	Sensor 5 to 50 Nm	5	50	N/A	5-50
E.6000-C30	Sensor 1 to 30 Nm	1	30	1-2	3-30

Torque Calibration Bench

- Secure and stable fixture to ensure accuracy for calibration to ISO 6789.
- Calibrate wrenches up to 1000N.m capacity.
- Adjustable to ensure precise horizontal location.
- 1200:1 gearbox for precise and controlled loading within prescribed time limits.
- For use with FACOM E.6000 series calibration sensors.



Model	Capacity [N.m]	ΔΔ [g]
CD.12A	1000	1250

Torque Calibration Sensors

- Modular system up to 1000 N.m capacity.
- Accuracy exceeds ± 1% in line with ISO 6789.
- Less than 0.5% from 10-100% of the range.
- For use stand alone or with CD12.A calibration bench.
- 2 sets of mounting holes : horizontal or vertical.
- Requires FACOM control software to be installed on a Windows PC with a spare USB port.
- USB connection to host required for data and power.
- Included square drive adaptors accommodate all drive sizes.
- Supplied in a durable blow moulded storage case, with a calibration certificate.



Model	Capacity [N.m]	Square	ΔΔ [kg]
E.6000-C08	0.04-1	-	0.8
E.6000-C5	0.5-5	-	0.8
E.6000-C30	1-30	1/4"	1
E.6000-C50	5-50	3/8"	1
E.6000-C400	20-400	1/2"	1
E.6000-C1000	10-1000	3/4"	2.5

CDS - Screwdriver torque meters

- Accuracy: +/- 2% of the read value, between 20% and 100% of the maximum capacity.
- Numbered delivery device with calibration certificate.
- Large dial follower and dial for easy and error-free reading.
- Dimensions: 250 x 150 x 100 mm.
- Delivered with 2 squares.



Model	Capacity [cN.m]	Capacity [lbf.in]	F Square	Male Square	Graduation [Cn.m]	Graduation [lbf.in]	Graduation [N.m]
CDS.1	7 -> 35	-	1/4"	1/4"	0.5	-	-
CDS.2	26 -> 130	-	1/4"	1/4"	2	-	-
CDS.3	0,8 -> 4	7 -> 36	1/4"	1/4"	-	0.5	0.05
CDS.4	2,4 -> 12	24 -> 120	1/4" - 3/8"	-	-	2	0.2





SCREWDRIVERS - KEYS - BITS



SCREWDRIVERS

416

PROTWIST® screwdrivers sets and modules	418
PROTWIST® screwdrivers for slotted head screws	419
PROTWIST® screwdrivers for Phillips® screws	422
PROTWIST® screwdrivers for Pozidriv® screws	423
PROTWIST® screwdrivers for square head screws	424
PROTWIST® screwdrivers for Torx® and Resistorx® screws	424
PROTWIST® stainless steel screwdrivers	426
PROTWIST® SHOCK screwdrivers	428
PROTWIST® 1,000 Volt insulated screwdrivers sets and modules	430
PROTWIST® 1,000 Volt insulated screwdrivers	431
PROTWIST® BORNEO® screwdrivers for electrical terminals	433
ISORYL screwdrivers for slotted head screws	434
ISORYL screwdrivers for Phillips® screws	435
ISORYL screwdrivers for Pozidriv® screws	436
Sets of wood handle screwdrivers	436
Wood handle screwdrivers for slotted head screws	437
Wood handle screwdrivers for cross-headed screws	437
Multiblade screwdrivers	438
Bit-holding screwdrivers	441
Voltage-tester screwdrivers	442
Magnetiser - Demagnetiser	442
Screw holder	443
Angled screwdrivers	444



KEYS

444

Key sets in bag	444
Key ringsets	445
Key sets in bag	445
Wallet of keys	447
Sleeve-sets of keys	448
Hexagon keys	449
Stainless steel hexagon keys	451
Torx® hexagon keys	452
Spinner keys - P spinner keys	453
Special profile keys	457



SCREW BITS

458

Standard bits series 0 - drive 4 mm	459
Standard bits series 1 - 1/4" - 6.35 mm drive	460
Sets of standard series 1 bits + bit holder in bag - 1/4" - 6.35 mm drive	464
Modules of standard series 1 bits - 1/4" - 6.35 mm drive	466
High power bits series 1 - 1/4" - 6.35 mm drive	466
High power Titanium bits series 1 - 1/4" - 6.35 mm drive	468
Standard bits series 2 - 5/16" - 7.94 mm drive	469
Standard bits series 6 - 1/4" - 6.35 mm grooved drive	471
Sets of high power series 6 bits - 1/4" - 6.35 mm grooved drive	473
Bit holders and accessories for manual screwing	474
Bit holders and accessories for non impact powered screwing	475
Series 2 impact bits - 5/16" - 7.94 mm drive	476
Impact bits series 3 - 1/2" drive - 12,7 mm	478
Impact bits sets	479
3/8" drive series impact screwdriver	480
1/2" drive series impact screwdriver	481

FLUO
RFid

HIGH PERFORMANCE SCREWDRIVERS

PROTWIST® Next generation
+100% Longer tip life*.
More comfort.



New handle "Channel"
+10% Torque

Laser marking
Virtually permanent marking

New improved handle material
Softer and chemical resistant

New inline hardening
+100% Bar strength*

Blade "tri-coating" treatment (Zinc-Nickel-Chromium)
4x Corrosion resistance*

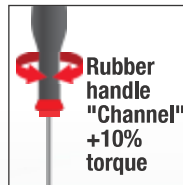
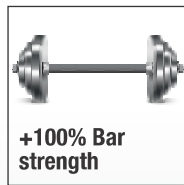
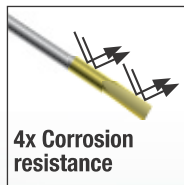
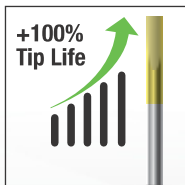

Chemical resistant
Softer grade

SPECIFIC RANGES



SHOCK

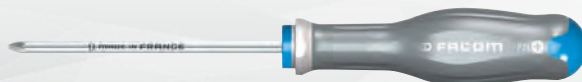

STAINLESS



1000VOLTS
1000V



RFID FLUO

*Versus current FACOM Protwist

CHOOSING THE RIGHT SCREWDRIVER FOR YOUR NEEDS

Model	PROTWIST	POWER	SHOCK	STAINLESS	INSULATED	TETHERED SLS	RFID	FLUO
	AT	ATWH	ATW.CK	AT.ST	AT.VE	AT.SLS	AT.RFID	AT.F
	1. Stubby 2. Standard 3. Long Reach	1. Standard	1. Standard	1. Standard	1. Standard	1. Standard	1. Stubby 2. Standard 3. Long Reach	1. Stubby 2. Standard 3. Long Reach
	2.5mm-12mm	5.5mm-14mm	4mm-14mm	4mm-8mm	2.5mm-12mm SLIM 3.5-6.5mm	2mm-10mm	2mm-10mm	2.5mm-10mm
	0-4	1-4	1-3	1-2	0-4 SLIM 1-2	1-2	0-3	0-3
	0-4	1-4	1-3	1-2	0-3 SLIM 1-2	1-3	0-3	2
	1-3	-	-	-	-	-	-	-
	6-40	-	-	10-40	-	-	10-40	15-20
	10-40	-	-	-	-	-	-	-
	5-40	-	-	-	-	-	-	-
	10-40	-	-	-	-	-	-	-
	-	-	-	-	1-2 PH/1-2 PZ SLIM 1-2 PH/1-2 PZ	-	-	-
	-	-	-	-	-	-	2-8	3-4-5
	-	-	-	-	-	-	PZ1-2. PH1-2 Slotted 2-8	PZ1-2. PH1-2 Slotted 2.5-5.5

Model							
Key market	IA/PRO	IA/PRO	Heavy duty. AutoPro Construction	Food/Marine Aerospace	Electrical	Work at height/mobile contractors	Aerospace
Position	Intensive Long life	Ultimate torque	Unbreakable	No FOD/hygiene	Live work	Tool security	Tool detection
Key feature	New CNC milling* New heat treatment Optimised bar materials	Hex blade and bolster	Through tang impact start	Stainless steel	Fully insulated 1000 volts VDE Slim profile	Tethered	Fluo
Key benefit	+100% Tip life	High torque = harder screwing	Screw release	Rust resistance	Electrical safe Narrow access	No risk of falling tools	High visibility

*Computer Numerical Control.

