

LASER

■ Laser distance measurer

IEC/EN60825-1: 2014

- Compact, lightweight design for easy storage.
- One button for simple operation.
- Press one button for both hold measurements and continuous measuring.
- Range: 0,165 -> 30m.
- Measuring accuracy: +/- 3 mm -> 10m.
- Smallest unit displayed: 1 mm.
- Laser class: Class 2 (IEC/EN60825-1: 2014).
- Laser type: 620-690 nm, power < 1mW.
- Unit automatic switch-off: After 180 s.
- Battery life (2x AAA): up to 3000 measurements.
- Storage temperature: - 10°C -+ 60°C.
- Operating temperature range: 0°C - + 40°C.

*Including batteries.



Model	H [mm]	L [mm]	W [mm]	ΔΔ [kg]
E.LM30	120	46	30	0.112*



FLUO

RFid



METROLOGY INTRODUCTION TO THE STANDARDS

DIN 862 - Vernier and digital caliper measurements from 0 to 2,000 mm.

Vernier or circular scale reading to 0.1 / 0.05 / 0.02 mm.

- Dimensional standard

Rule length (mm)	Height of lower jaw a1 (mm)	Height of upper jaw a1 (mm)	Total thickness for inside measurement a1 (mm)	Extent of depth gauge a1 (mm)
160	40	8	5	100
200	60	8	10	100
250	75	10	10	100
300	90	10	10	100

- Accuracy

Rule length (mm)	Limit of error in μm			
	Accuracy			Digital reading
	0.1 / 1/10 th	0.05 / 1/20 th	0.02 / 1/50 th	0.01 / 1/100 th
50	50	20	20	20
100	50	20	20	20
200	50	30	30	30
300	50	30	30	30

- Hardness of measuring surfaces. +/- 53 HRC for stainless steel.
- Digital display measurements:
 - Rate of displacement > standard (0.5m/s).
 - Error notification in case of: - Excessive speed.
 - Low power.

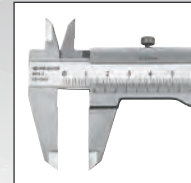

DIN 863 - Part 1 - Outside micrometers - Standard design

Mechanical and digital display micrometer.

- Dimensional standard: - Anvil diameter 6.5 - 7.5 or 8 mm.
- Tolerance of flatness of measuring surfaces 0.6 μm .
- The locking lever must not alter the reading by more than 2 μm .
- Thimble graduation.

Measurement range (mm)	Bias error (μm)	Parallelism tolerance Applied force = 10N (μm)	Frame bending tolerance Applied force = 10N (μm)
0-25	4	2	2
25-50	4	2	2
50-75	5	3	3
75-100	5	3	3

Other specifications covered by the standard.

- Maximum force applied to the measured component between 5 and 10 N.
- The quality of the materials used and their elasticity under load.

DIN 875 - Engineers square.

- Accuracy class.
- Perpendicularity tolerance of 2 surfaces.
- Flatness of edges.
- Legal markings.

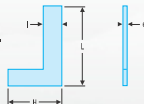

Dim. (L) mm	Perpendicularity tolerance (μm)		
	0	1	2
75	7	14	28
100	7	15	30
150	8	18	35
200	9	20	40
250	10	23	45
300	11	25	50
500	15	35	70

Dim. (L) mm	Height	
	Class 00/0/1	Class 2
75	50	50
100	70	70
150	100	100
200	130	130
250	165	165
300	200	175
500	330	250

L x H mm	Flatness tolerance (μm)		
	0	1	2
50	3	5	10
70	3	5	11
75	3	6	11
100	3	6	12
130	3	7	13
150	4	7	14
165	4	7	15
200	4	8	16
250	5	9	18
300	5	10	20
330	5	11	-
500	7	14	28

DIN 878 Dial gauges to 1/100 mm.

- Dimensional standard.
- Definition of accuracy.
- Measuring force - between 0.3 N and 1.5 N.

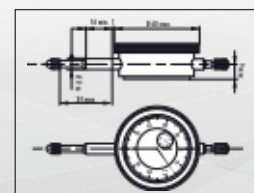

DIGITAL CALIPER



Easy, efficient and reliable!

Easy to use

- Clear, easy-to-read LCD screen.
- More intuitive use.
- Quick and easy to operate.
- Easier data transmission.

Reliable

- DIN 862.
- Ingress protection (IP) – IEC529.
 - Protection against dust and liquids. For perfect reliability under all operating conditions.
 - IP 6x = No dust penetration.
 - IP x5 = Protected against water jets from any direction for 3 minutes.
- Patented inductive measuring system.
- RS 232 connection.
- PC data transmission utility.

Efficient data transmission

- Gagewedge utility program developed for FACOM.
- Reliable data recording.
- Saves time, simple and easy to use.
- Compatible with the entire FACOM digital range.
- Easy RS232 cable connection between the measuring instrument and the PC.

CALIPERS

Digital display calipers - 1/100th

NF EN ISO 13385-1, ISO 13385-1, DIN 862

- Accuracy: 1/100th - 0.01 mm.
- Repeatability: 10 µm.
- Protection rating IP 65:
 - IP 6: full dust protection.
 - IP 5: fluid spray protection.
- Rectified stainless steel mechanical assembly.
- Reading rule with patented induction system.
- Flat depth gauge.
- LCD digital display 6 mm.
- Floating zero.
- Metric / imperial conversion.
- Automatic power off.
- Compatibility with Gagewedge software, RS232 output.
- Operating time: about 3500 hours.
- Supplied in case with compliance certificate.

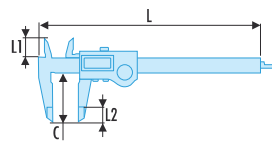

	C [mm]	L [mm]	L1 [mm]	L2 [mm]	Capacity [mm]	Bias error [µm]	ΔΔ [g]
1320	50	290	20	14	200	30	680

Workshop digital display caliper 150 mm - 1/100th

NF EN ISO 13385-1, ISO 13385-1, DIN 862

- Pocket-size caliper to be used in the workshop.
- Accuracy: 1/100th - 0.01 mm.
- Digital display for easy reading (resolution 0.01 mm).
- Measurements: mm / inch. Inside / outside / depth measurement.
- Protection rating IP 20.
- Supplied with CR2032 battery.

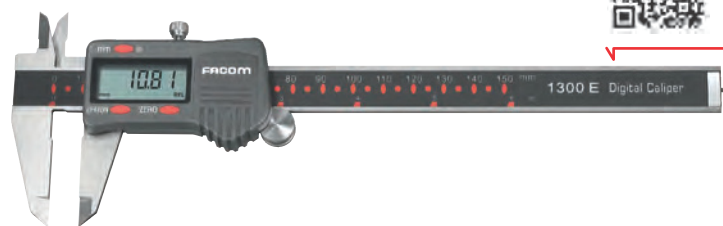

	L [mm]	Capacity [mm]	ΔΔ [g]
1300EA	235	150	420

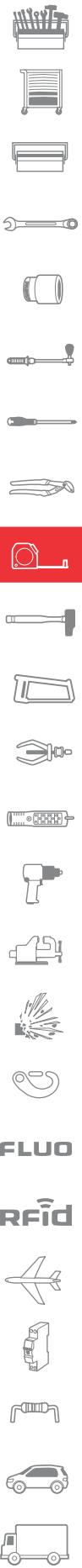

DEPTH GAUGE

■ Digital display depth gauge 300 mm - 1/100th

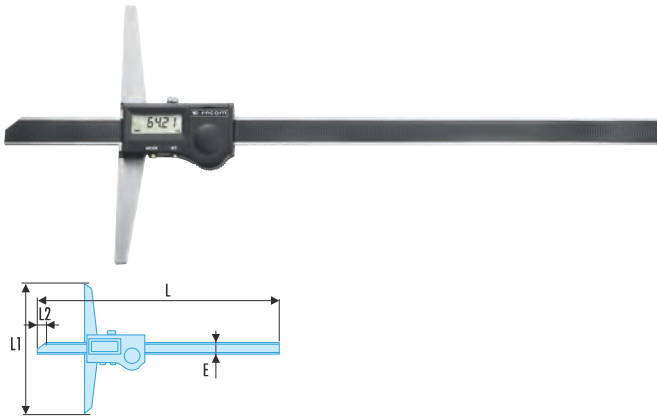

NF EN ISO 13385-1, ISO 13385-1, DIN 862

- Accuracy: 1/100th - 0.01 mm.
- Repeatability: 10 µm.
- Protection rating IP 65:
 - IP 6: full dust protection.
 - IP 5: fluid spray protection.
- Rectified stainless steel mechanical assembly.
- Reading rule with patented induction system.
- LCD digital display 6 mm.
- Floating zero.
- Metric / imperial conversion.
- Compatible with Gagewedge software, RS232 output.
- Automatic power off.
- Operating time: about 3500 hours.
- Supplied in case with compliance certificate.



	E [mm]	L [mm]	L1 [mm]	L2 [mm]	Capacity [mm]	Bias error [µm]	ΔΔ [g]
1350	16	372	150	10	300	20	928

MICROMETER

■ Digital display micrometer 25 mm



NF EN ISO 3611, ISO 3611, DIN 863

- Accuracy: 0.001 mm.
- Measurement range: 0 - 25 mm.
- Adjustable measuring force: 10 N (DIN 863).
- Protection rating IP 65:
 - IP 6: full dust protection.
 - IP 5: fluid spray protection.
- Automatic standby after 20 min.
- Stand by position without loss of origin.
- Fast forward: Drum forward 12 mm / turn.
- Compatibility with Gagewedge software, RS232 output.
- Operating time: 10 000 hours continuous.
- Supplied in case with compliance certificate.



	Capacity [mm]	ΔΔ [g]
1355A	0 - 25	270

DIAL GAUGE

■ Digital display dial gauge



DIN 878

- Accuracy: 0.001 mm.
- Measurement range: 0 - 12.5 mm.
- Metric / imperial conversion.
- Protection rating IP 51.
- LCD display 6 mm.
- Fastening bush (Ø 8 mm).
- Interchangeable plunger tip (M2.5).
- Display pivots through 270°.
- Floating zero.
- Change of origin for any tip position.
- Measurement possible with two different references.
- Measurement save (frozen display).
- Compatibility with Gagewedge software, RS232 output.
- Supplied with FACOM compliance certificate.



	Capacity [mm]	ΔΔ [g]
1365	0 - 12,5	120

MECHANICAL CALIPERS

MECHANICAL METROLOGY

Improved performance



Extra service

Have your measuring instruments inspected each year by an accredited organisation to guarantee their accuracy.



Outside measurement.



Inside measurement.



Throat measurement.



Step measurement.



Depth measurement.

Compliance with DIN 862

- Dimensional regulation.
- Hardness of measuring faces.
- Accuracy and limit of error in μm .
- Standard of quality and readability of graduations.

Technical specifications

- Ground stainless steel.
- Lock screw for reliable readings without risk of slippage.
- Vernier with guide. Natural hand position.
- Increased comfort.

Perfect reading quality

- Good contrast and anti-reflection.
- Excellent readability.
- Chemically formed graduation markings for perfect resistance to wear and chemical agents.

Accuracy

- To 1/50 – 1/20 – 1/10 mm.

Traceability

- Supplied with a numbered certificate of conformity.

805 - Universal calipers class 0 - 1/50th

NF EN ISO 13385-1, ISO 13385-1, DIN 862

- Accuracy: 1/50th - 0.02 mm.
- Interior, exterior, depth measurement.
- Stainless steel rule - mat finish.
- Rule hardness: 40 HRC minimum.
- Flat depth gauge.
- Vernier with guide for better thumb position.
- Vernier endurance: 20 000 cycles minimum.
- Vernier screw locking.
- Supplied in case with compliance certificate.

Model	A [mm]	C [mm]	E [mm]	L [mm]	Bias error [μm]	Accuracy [mm]	$\Delta\Delta$ [g]
805.1	150	40	16	228	20	0,02	290
805.2	200	50	17	290	30	0,02	419

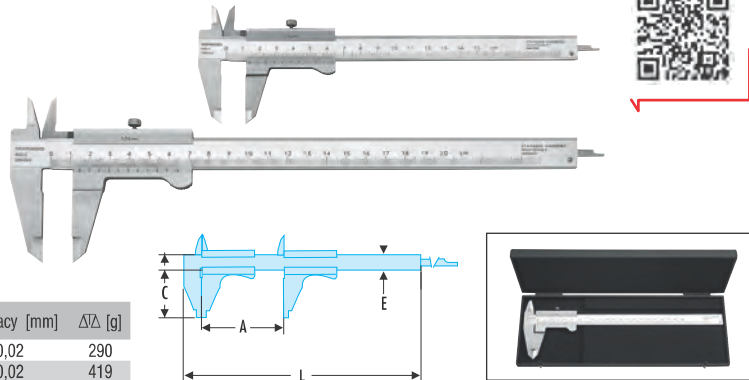

Caliper class 0 - 1/50th

NF EN ISO 13385-1, ISO 13385-1, DIN 862

- Accuracy: 1/50th - 0.02 mm.
- Measurement capacity: 200 mm.
- Interior, exterior measurement (bore exceeding 10 mm).
- Stainless steel rule - mat finish.
- Rule hardness: 40 HRC minimum.
- Vernier with guide for better thumb position.
- Vernier endurance: 20 000 cycles minimum.
- Vernier screw locking.
- Graduations resistant to chemicals.
- Perfect contrast guaranteeing optimum reading quality.
- Supplied in case with compliance certificate.

Model	A [mm]	C [mm]	E [mm]	L [mm]	Bias error [μm]	Accuracy [mm]	$\Delta\Delta$ [g]
805.M	200	60	17	290	30	0,02	423

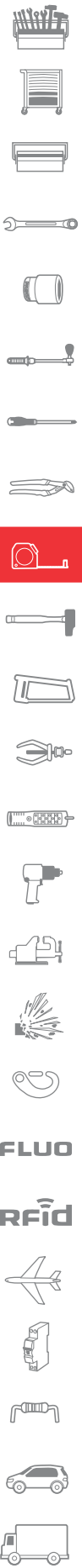
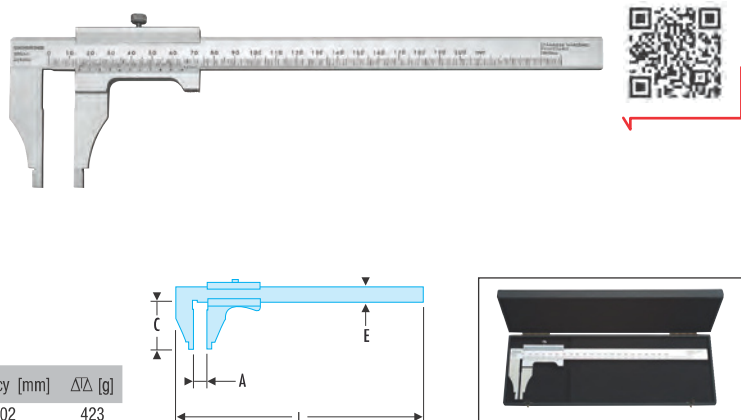

MECHANICAL CALIPERS

■ Universal caliper - 150mm - 1/20th

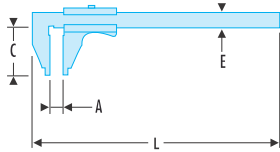

NF EN ISO 13385-1, ISO 13385-1, DIN 862

- Accuracy: 1/20th - 0.05 mm.
- Interior, exterior, depth measurement.
- Stainless steel rule - mat finish.
- Rule hardness: 40 HRC minimum.
- Flat depth gauge.
- Vernier with guide for better thumb position.
- Vernier endurance: 20 000 cycles minimum.
- Vernier screw locking.
- Supplied in case with compliance certificate.

Part No.	A [mm]	C [mm]	E [mm]	L [mm]	Bias error [µm]	Accuracy [mm]	ΔΔ [g]
816	150	40	16	228	50	0,05	288

■ Universal caliper - 300 mm - 1/50th

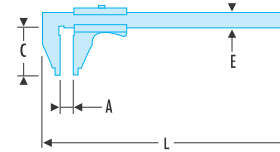
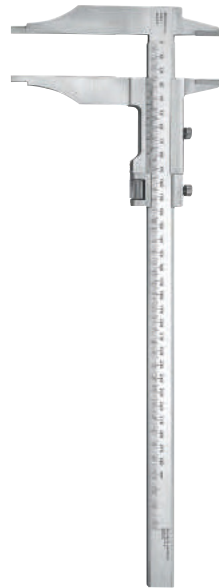

NF EN ISO 13385-1, ISO 13385-1, DIN 862

- Accuracy: 1/50th - 0.02 mm.
- Measurement capacity: 300 mm.
- Interior, exterior measurement (bore exceeding 10 mm).
- Stainless steel rule - mat finish.
- Rule hardness: 40 HRC minimum.
- Vernier with guide for better thumb position.
- Vernier endurance: 20 000 cycles minimum.
- Vernier screw locking.
- Precision adjustment screw.
- Supplied in case with compliance certificate.

Part No.	A [mm]	C [mm]	E [mm]	L [mm]	Bias error [µm]	Accuracy [mm]	ΔΔ [g]
805.S	300	100	20	418	30	0,02	941

MECHANICAL DEPTH GAUGES

■ 811 - Depth gauges class 0 - 1/50th

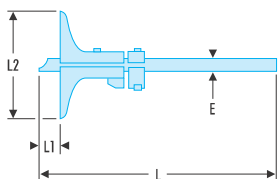
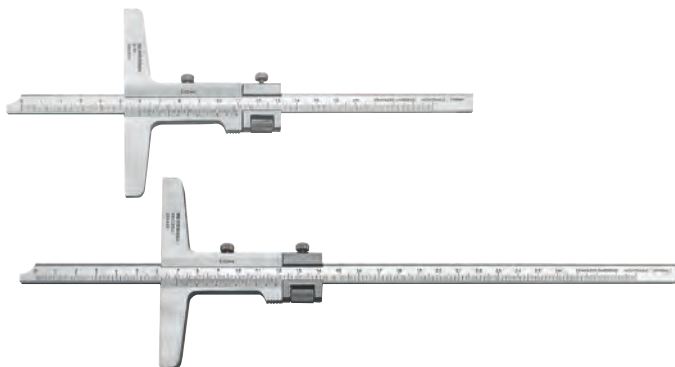

NF EN ISO 13385-2, ISO 13385-2, DIN 862

- Accuracy: 1/50th - 0.02 mm.
- Stainless steel rule - mat finish.
- Rule hardness: 40 HRC minimum.
- Measurement surface hardness: 53 HRC minimum.
- Vernier with guide for better thumb position.
- Vernier endurance: 20 000 cycles minimum.
- Vernier locking by precision adjustment screw.
- Supplied in case with compliance certificate.

Part No.	A [mm]	E [mm]	L [mm]	L1 [mm]	L2 [mm]	Bias error [µm]	Accuracy [mm]	ΔΔ [g]
811B	160	10	240	160	100	20	0,02	465
811C.250	250	10	330	250	100	30	0,02	491

MECHANICAL MICROMETERS

806 - Micrometers
1/100th mm accuracy



NF EN ISO 3611, ISO 3611, DIN 863

- Accuracy: 1/100th - 0.01 mm.
- Accuracy: 0.01 mm.
- Carbide plunger tip: Ø 6.5 mm.
- Ratchet drum with torque limiter.
- Force applied on the part included strictly between 5 and 10 Nm.
- Drum: Ø 18 mm.
- Drum with 50 divisions (one drum turn: 0.5 mm).
- Isothermal pads.
- Supplied with:
 - Pin and hook calibration wrench.
 - Calibration shim wrench from model 806C.50.
- Calibration shims:
 - 806C.50: 25 mm ± 1.5 µm.
 - 806C.75: 50 mm ± 2 µm.
 - 806C.100: 75 mm ± 2.5 µm.
- Supplied in plastic case.
- Supplied with compliance certificate.

806	Bias error [µm]	Parallelism of measuring faces [µm]	Measuring range [mm]	Flatness of measuring surfaces/Max.[µm]	ΔΔ [g]
806.C25	4	2	0 - 25	0,4	310
806C.50	4	2	25 - 50	0,4	482
806C.75	5	3	50 - 75	0,4	631
806C.100	5	3	75 - 100	0,4	744

Exterior friction micrometer
1/100th mm accuracy



NF EN ISO 3611, ISO 3611, DIN 863

- Accuracy: 1/100th - 0.01 mm.
- Accuracy: 0.01 mm.
- Carbide plunger tip: Ø 6.5 mm.
- Ratchet drum with torque limiter.
- Force applied on the part included strictly between 5 and 10 N.m.
- Drum = Ø 18 mm.
- Plunger tip lock.
- Supplied in plastic case.
- Supplied with compliance certificate.

806.F	Capacity [mm]	Bias error [µm]	Parallelism of measuring faces [µm]	Flatness of measuring surfaces/Max.[µm]	ΔΔ [g]
806.F	0 - 25	4	2	0,4	273

Exterior micrometer with extension 1/100th mm accuracy

NF EN ISO 3611, ISO 3611, DIN 863

- Accuracy: 1/100th - 0.01 mm.
- Reading range 0 to 150 mm.
- Accuracy: 0.01 mm.
- Ratchet drum with torque limiter.
- Force applied on the part included strictly between 5 and 10 N.m.
- Drum: Ø 18 mm.
- Carbide plunger tip: Ø 6.5 mm.
- Interchangeable fixed plunger tip.
- Supplied with a set of 5 extensions.
- Supplied with the 5 calibration shims.
- Calibration shims:
 - 807.CALE25: 25 mm ± 1.5 µm.
 - 807.CALE50: 50 mm ± 2 µm.
 - 807.CALE75: 75 mm ± 2.5 µm.
 - 807.CALE100: 100 mm ± 3 µm.
 - 807.CALE125: 125 mm ± 3.5 µm.
- Isothermal pads.
- Plunger tip lock.
- Supplied in wood case.
- Supplied with compliance certificate.

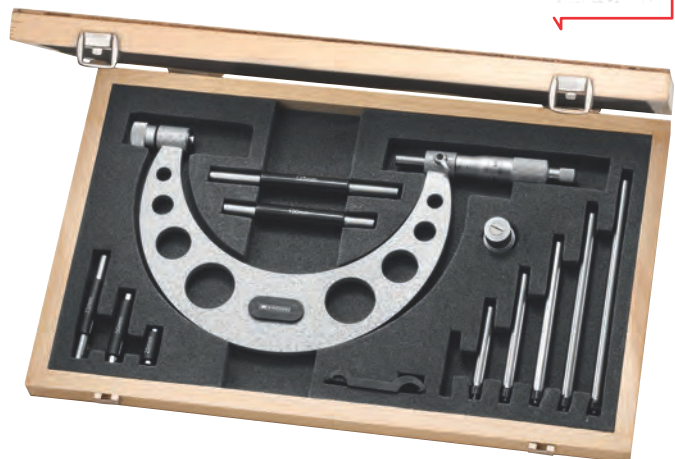

807C	ΔΔ [kg]
807C	1800



METROLOGY SETS

■ Metrology module



- 805.1: mechanical caliper capacity 1/50 mm.
- 806.F: palmer 1/100 mm capacity 25 mm.
- 814.M: screw pitch gauge 23 blades, 25 to 300.
- 804: metric feeler gauges 4/100 to 1 mm.
- Thermoformed module PL634.



	H [mm]	l [mm]	L [mm]	ΔΔ [g]
MOD.MET	40	175	418	930

■ Metrology-control case 8 tools



Including:

- 805.M: caliper to 1/50 mm (capacity: 200 mm).
- DELA.1051.300: stainless rule 300 mm.
- 811: depth gauge 1/50 mm (capacity: 160 mm), fine adjustment by return screw.
- 818B.15: simple square 150 mm (accuracy class: 1).
- 236: carbide scriber.
- 256.4: punch.
- 806.C25: micrometer 1/100 mm (capacity: 25 mm).
- 1901.05: straight scriber (capacity: 150 mm).



	H [mm]	L [mm]	P [mm]	ΔΔ [kg]
809.J2	30	365	260	2.1

■ Metrology-control case 10 tools



Including:

- 805.M: caliper 1/50 mm (capacity 200 mm).
- 806.C25: micrometer 1/100 mm (capacity: 25 mm).
- 806C.50: micrometer 1/100 mm (capacity: 25 - 50 mm).
- 811: depth gauge 1/50 mm (capacity: 160 mm), fine adjustment by return screw.
- 818B.15: simple square 150 mm (accuracy class 1).
- 819B.15: flanged square 150 mm (accuracy class 1).
- 1901.05: straight scriber 150 mm.
- 236: carbide scriber.
- DELA.1051.300: stainless rule 300 mm.
- 256.4: punch.



	H [mm]	L [mm]	P [mm]	ΔΔ [kg]
809.J3	40	410	280	3.6

MECHANICAL DIAL GAUGES

▪ Dial gauge 1/100th mm accuracy



- Accuracy: 1/100th - 0.01 mm.
- Travel 10 mm saved with totaller.
- Pivot dial: Ø 57 mm.
- Interchangeable plunger tip.
812B.1AC: Steel ball plunger for 812B.AC dial gauge

	$\Delta\Delta$ [g]
812B.AC	345

▪ Lever dial gauge 1/100th mm accuracy



- Accuracy: 1/100th - 0.01 mm.
- Travel: 0.8 mm.
- Pivot dial: Ø 31 mm.
- Supplied with 2 fastening rods: Ø 4 and 8 mm.
- Plunger tip: Ø 2 mm.

	$\Delta\Delta$ [g]
812B.P	154

▪ Dial gauge-magnetic base set



- Dial gauge 812B.AC supplied with the hinged magnetic holder 812.3.

	$\Delta\Delta$ [kg]
812A	2.245

▪ Dial gauge-hinged magnetic base set



- Radius of action: 280 mm.
- Vertical tear strength: 600 N (60 kg).
- Threading Ø: M8.
- Base: 50 x 55 x 60 mm.

	$\Delta\Delta$ [kg]
812.3	1.9



SURFACE GAUGES

■ Precision surface gauge 300 mm - 1/50th



- Class 0.
- Precision 1/50th - 0.02 mm.
- Accuracy error: $\pm 28\mu\text{m}$.
- Reliability error: $\pm 12\mu\text{m}$.
- Stainless steel rule - mat anti-reflection finish:
 - Width: 25 mm.
 - Hardness 40 HRc minimum.
- Maximum measurement capacity: 300 mm.
- Steel alloy scriber:
 - Hardness 53 HRc minimum.
 - Better scribing quality.
 - 796B.04: serial no. A02 0001 --> march 01.
 - 796C.04: serial no. A02 0001 --> A04 0001.
- Fine adjustment by return screw.
- Repositionable magnifying glass.
- Dial gauge base supplied in standard: for dial gauge with $\varnothing 8$ mm rod (DIN 878 standard).
- Total dimensions: 455 mm x 90 mm.
- Supplied with compliance certificate.

	$\Delta\Delta$ [kg]
796B	3.280

■ Engineers surface gauges



- Model without graduation.
- Fine adjustment by pivot strip using a push screw.
- Cast iron base.
- Vertical face with 90° V groove.
- Rod: $\varnothing 10$ mm.

	$\Delta\Delta$ [kg]
795A	1.745

SURFACE PLATES AND V-BLOCK

■ Cast iron surface plates



- DIN 876
- Class II.



	Dimension [mm]	$\Delta\Delta$ [kg]
1200.50	500 x 300	22

■ 1202.00 - Pair of steel V-blocks - 20 microns



- ISO 8512-1, DIN 876
- Pair of vees with 4 90° notches.
 - Paired vees, identification number punched on the upper face.



	Dimension [mm]	$\Delta\Delta$ [kg]
1202	30 x 40 x 50 x 60	7.4
1202.00	20 x 30 x 40 x 50	2.8

RADIUS GAUGES

DELA - Radius gauges

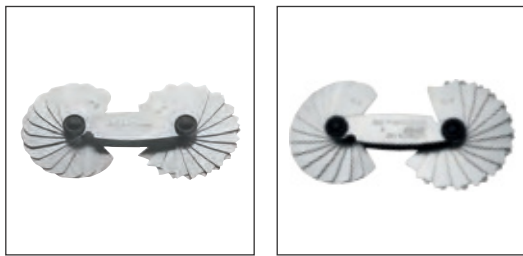

- To check the radii of fillets and connections.
- Tempered steel blades.
- 3 models for concave and convex radii 1 to 25 mm.

DELA	A [mm]	Content set	Number of Blades	ΔΔ [g]
DELA.1786.00	1,0 --> 7,0	1,00 - 1,25 - 1,50 - 1,75 - 2,00 - 2,25 - 2,50 - 2,75 - 3,00 - 3,50 - 4,00 - 4,50 - 5,00 - 5,50 - 6,00 - 6,50 - 7,00	34	600
DELA.1787.00	7,5 --> 15,0	7,50 - 8,00 - 8,50 - 9,00 - 9,50 - 10,00 - 10,50 - 11,00 - 11,50 - 12,00 - 12,5 - 13,00 - 13,50 - 14,00 - 14,50 - 15,00	32	720
DELA.1790.00	15,5 --> 25,0	15,50 - 16,00 - 16,50 - 17,00 - 17,50 - 18,00 - 18,50 - 19,00 - 19,50 - 20,00 - 21,00 - 22,00 - 23,00 - 24,00 - 25,00	30	350

SCREW PITCH GAUGES

814 - Screw pitch gauges



814	Content set	Number of Blades	Thread Forms	ΔΔ [g]
814.M	25 - 30 - 35 - 40 - 45 - 50 - 55 - 60 - 65 - 70 - 75 - 80 - 85 - 90 - 100 - 110 - 120 - 125 - 130 - 140 - 150 - 160 - 170 - 175 - 180 - 190 - 200 - 225 - 250 - 275 - 300	60° cutting gauge + 31 blades	Metric thread	53
814.NI	0,25 - 0,30 - 0,35 - 0,40 - 0,45 - 0,50 - 0,60 - 0,70 - 0,75 - 0,80 - 1,00 - 1,25 - 1,50 - 1,75 - 2,00 - 2,50 - 3,00 - 3,50 - 4,00 - 4,50 - 5,00 - 5,50 - 6,00 - 6,50 - 7,00	60° cutting gauge + 25 blades	I.S.O thread	420
814.WH	4 - 4,5 - 5 - 6 - 7 - 8 - 9 - 10 - 11 - 12 - 13 - 14 - 16 - 18 - 19 - 20 - 22 - 24 - 25 - 26 - 28 - 30 - 32 - 34 - 36 - 38 - 40 - 48 - 60	55° cutting gauge + 29 blades	Whitworth thread	40
814.G	Filets intérieurs : 11 - 14 - 19 - 28 Filets extérieurs : 11 - 14 - 19 - 28	8 blades	Gas thread	150

SEE THE FEELER GAUGES SECTION 23

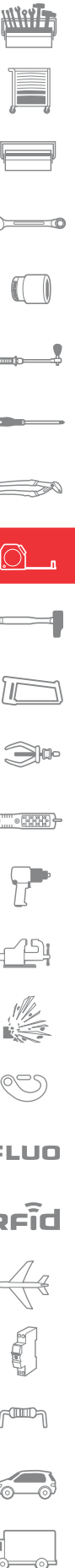
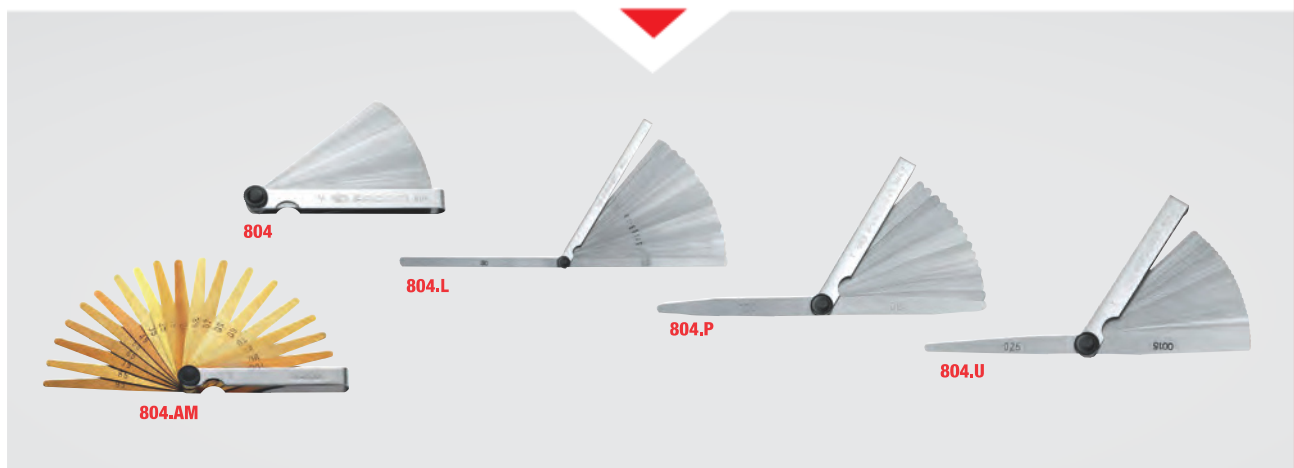

RULERS

A FACOM specialty, rigorous expertise

Tight production control: our rulers have been produced in our plants located in France since 1918.

Chemical engraving

- Deep markings.
- Perfect contrast.
- Resistant to wear and chemical agents.

Rigorous selection of materials guaranteeing the highest quality

- Compromise between rigidity and flexibility.
- Mat surface for perfect readability.
- Smooth finish for fine, clean markings.

A range of over 20 references

- Stainless steel or duralumin.
- Rigid, semi-rigid, flexible.
- Graduation mm – 1/2 mm.

INFORMATION

European directive 2004/22/EC, necessary harmonisation and change.

- Measuring Instrument Directive - Annex MI-008 – material measures.
- Harmonisation of the regulations for the 25 Member States.
- Entry into force in France on 30 October 2006.
- Gradule implementation as pattern approvals expire.
- NB: Only measurements > 500 mm are considered in legal metrology (OIML 35).

No pattern and regulatory marking approvals are required for measurements < 500 mm.

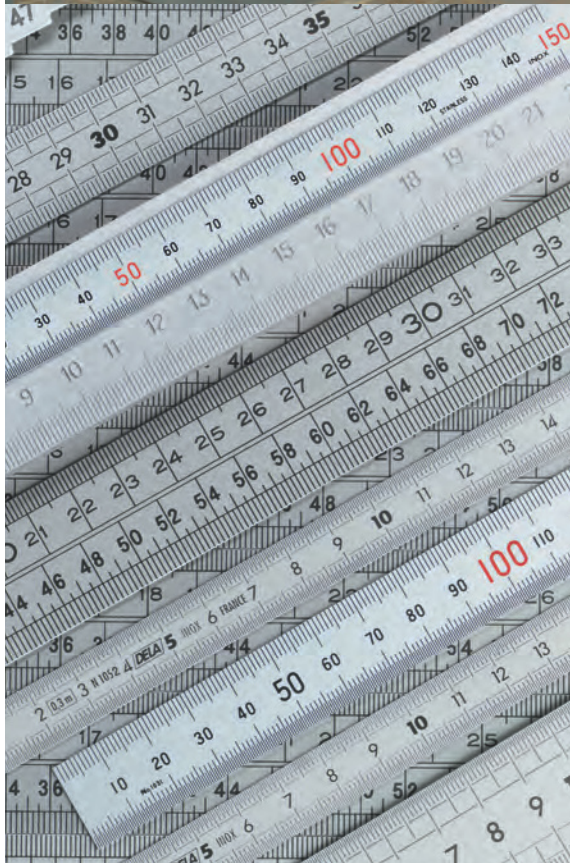

RULERS

ENGINEERS RULE

■ **Non graduated solid stainless steel ruler**

NF E 11-104, DIN 874

- Class I, flatness: $4 + L/60 \mu\text{m}$ (L being the length in mm).
- Stainless steel.
- Supplied in wood case.



	L [mm]	Section [mm ²]	$\Delta\Delta$ [g]
809.IN500	500	50 x 10	40

■ **Graduated solid stainless steel ruler**

NF E 11-105, DIN 874

- Class I, flatness: $4 + L/60 \mu\text{m}$ (L being the length in mm).
- With offset zero graduation.
- Supplied in wood case.



	L [mm]	Section [mm ²]	$\Delta\Delta$ [kg]
809.ING500	500	50 x 10	2.900

■ **809 - Stainless steel filament rulers**

NF E 11-104, DIN 874

- To check a surface or an edge.
- Tempered stainless steel with insulating handle.
- Supplied in wallet.





	L [mm]	Flatness of measuring surfaces/Max. μm	$\Delta\Delta$ [g]
809.75	75	2	80
809.100	100	2	125
809.150	150	3	200
809.200	200	3	280

CLASS II RULES

■ **DELA.1051 - Stainless steel rulers - 2 sides**

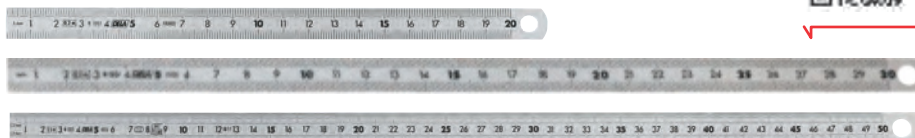
- Engraved on both sides.
- One edge in mm - One edge in 1/2 mm.
- Stainless steel 18 % Cr - 8 % Ni.
- Anti-reflection treatment.
- Class II as per regulations applies to rules with a length above or equal to 500 mm.



	L [mm]	L1 x L2 [mm]	$\Delta\Delta$ [g]
DELA.1051.150	150	13 x 0,5	124
DELA.1051.200	200	13 x 0,5	11
DELA.1051.300	300	13 x 0,5	16
DELA.1051.500	500	20 x 0,5	40

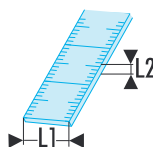

CLASS II RULE

DELA.1021 - Stainless steel rulers - 1 side

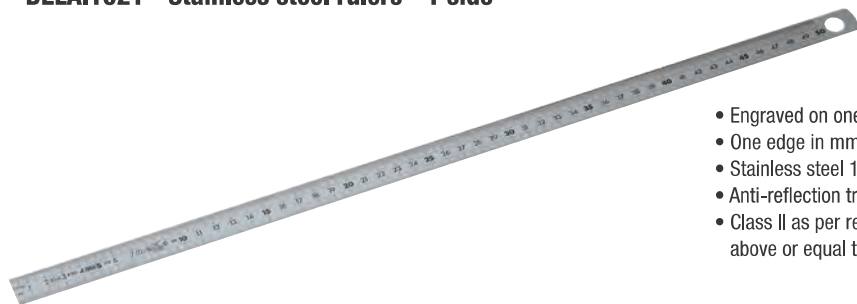

- Engraved on one side.
- One edge in mm - One edge in 1/2 mm.
- Stainless steel 18 % Cr - 8 % Ni.
- Anti-reflection treatment.
- Class II as per regulations applies to rules with a length above or equal to 500 mm.

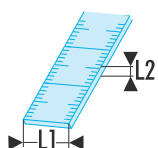

DELA	L [mm]	L1 x L2 [mm]	ΔΔ [g]
DELA.1021.1000	1000	25 x 0,5	100
DELA.1021.1500	1500	25 x 0,5	152
DELA.1021.2000	2000	25 x 0,5	200

DELA.1056 - Stainless steel semi-rigid short rulers - 2 sides



- Engraved on both sides.
- One edge in mm - One edge in 1/2 mm.
- Stainless steel 18 % Cr - 8 % Ni.
- Anti-reflection treatment.
- Class II as per regulations applies to rules with a length above or equal to 500 mm.

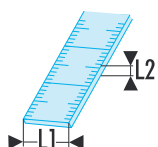

DELA	L [mm]	L1 x L2 [mm]	ΔΔ [g]
DELA.1056.300	300	30 x 0,8	60
DELA.1056.500	500	30 x 0,8	120

DELA.1056 - Stainless steel semi-rigid long rulers - 1 side



- Engraved on one side.
- One edge in mm - One edge in 1/2 mm.
- Stainless steel 18 % Cr - 8 % Ni.
- Anti-reflection treatment.
- Class II as per regulations applies to rules with a length above or equal to 500 mm.

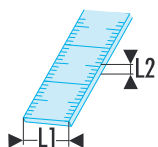

DELA	L [mm]	L1 x L2 [mm]	ΔΔ [g]
DELA.1056.1000	1000	30 x 0,8	100
DELA.1056.1500	1500	30 x 0,8	8,5
DELA.1056.2000	2000	30 x 0,8	11

PRECISION SQUARES

818.CLO - Stainless steel basic precision squares - Class 0

NF E 11-103, DIN 875

- Accuracy: $\pm 5 + h/50 \mu\text{m}$ (h being height in mm).
- Stainless steel.
- Ground exterior edges and flat surfaces.

818	E x E1 [mm]	H [mm]	L [mm]	$\Delta\Delta$ [kg]
818.75CLO	15 x 5	50	75	0,140
818.100CLO	20 x 5	70	100	0,220
818.150CLO	27 x 6	100	150	0,455
818.200CLO	31 x 7	130	200	0,760
818.300CLO	39 x 8	200	300	1,765

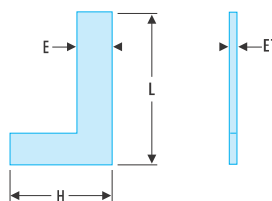

819.CLO - Stainless steel flanged precision squares - Class 0

NF E 11-103, DIN 875

- Accuracy: $\pm 5 + h/50 \mu\text{m}$ (h being height in mm).
- Stainless steel.
- Ground exterior edges and flat surfaces.

819	E x E1 [mm]	H [mm]	L [mm]	L1 [mm]	$\Delta\Delta$ [kg]
819.75CLO	15 x 5	50	75	15	0,175
819.100CLO	20 x 5	70	100	20	0,280
819.150CLO	27 x 6	100	150	28	0,600
819.200CLO	31 x 7	130	200	32	1,095
819.300CLO	39 x 8	200	300	40	2,337

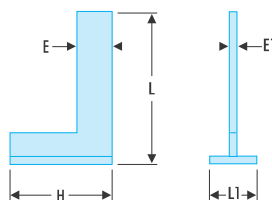

818B - Basic squares - Class I

NF E 11-103, DIN 875

- Ground sides and chamfers.
- XC12 steel.

818B	E x E1 [mm]	L x H [mm]	$\Delta\Delta$ [kg]
818B.10	19 x 5	100 x 70	0,130
818B.15	24 x 6	150 x 100	0,240
818B.20	30 x 7	200 x 130	0,410
818B.30	30 x 7	300 x 180	0,880

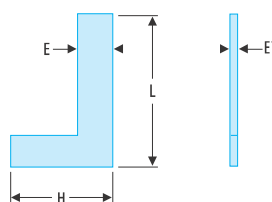

FLUO

Rfid



PRECISION SQUARES

Basic flanged squares - Class I

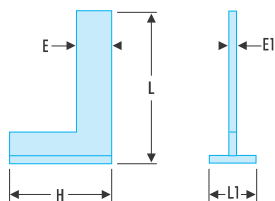

NF E 11-103, DIN 875

- Ground sides and chamfers.
- Screwed flange.
- XC12 steel.
- Supplied with compliance certificate.

REF	E x E1 [mm]	H [mm]	L [mm]	L1 [mm]	ΔΔ [kg]
8198.15	24 x 6	100	150	25	0,470

DELA.1256 - Basic squares - Class II

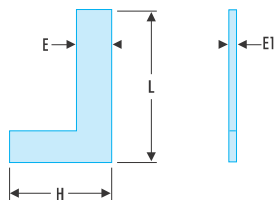

NF E 11-103, DIN 875

- Basic 90° squares.

REF	E x E1 [mm]	H [mm]	L [mm]	ΔΔ [kg]
DELA.1256.02	20 x 5	70	100	0,125
DELA.1256.04	20 x 5	100	150	0,290
DELA.1256.06	30 x 7	130	200	0,515
DELA.1256.07	30 x 7	165	250	0,580
DELA.1256.08	30 x 7	200	300	0,700
DELA.1256.10	40 x 7	330	500	1,800

DELA.1257 - Basic flanged squares - Class II

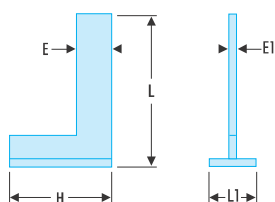

NF E 11-103, DIN 875

- Screwed flange.
- Perfect bearing of heel and side.

REF	E x E1 [mm]	H [mm]	L [mm]	L1 [mm]	ΔΔ [kg]
DELA.1257.02	20 x 5	70	100	20	0,200
DELA.1257.04	20 x 5	100	150	20	0,390
DELA.1257.06	30 x 7	130	200	30	0,715
DELA.1257.08	40 x 8	200	300	40	1,020
DELA.1257.10	40 x 7	330	500	40	2,600

OTHER SQUARES

817 - Dummy squares

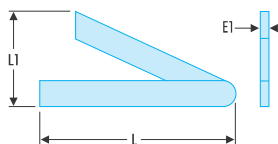
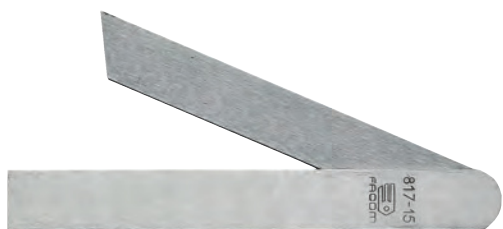

- Surface and edges in ground steel.

▣	E1 [mm]	L [mm]	L1 [mm]	ΔΔ [g]
817.15	15	150	19 - 145	465
817.20	15	200	24 - 195	491
817.25	15	250	24 - 240	300
817.30	15	300	24 - 285	480

Centering square

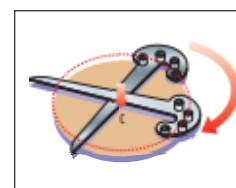

- Steel square with 4 symmetrical studs.
- Allows to determine the center of an arc of circle in two operations.

▣	ΔΔ [g]
DELA.1290.00	100

DELA.1272 - Flanged double tab squares



NF E 11-103, DIN 875

- Angles 30°, 45°, 60°, 90°.

▣	L [mm]	L1 [mm]	ΔΔ [g]
DELA.1272.01	100	78	663
DELA.1272.03	150	105	880
DELA.1272.04	200	142	300

Flanged square 45°

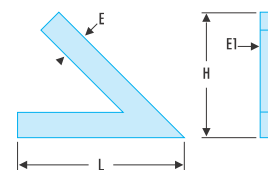

▣	E x E1 [mm]	H [mm]	L [mm]	ΔΔ [g]
DELA.1292.00	26 x 7	150	150	105



FLUO

Rfid



BEVEL PROTRACTORS

■ Bevel protractor



- Ground stainless steel.
- Base of the sector divided in mm.
- Double division reversed from 0 to 180°.
- Sector Ø: 85 mm.
- Rule length: 170 mm.
- Easy reading by an index inside a port.



Price	L [mm]	ΔΔ [g]
1885.00	170	150

■ High capacity bevel protractor

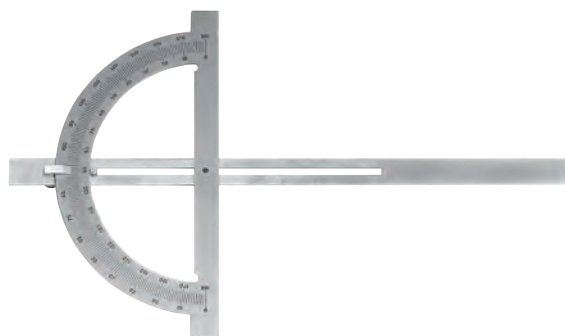

- Tempered steel.
- Graduations in degrees.
- Empty sector for measuring angles from 10 to 170°.
- Sector Ø: 200 mm.
- Rule length: 400 mm.
- Slide rule, screw locking.



Price	L [mm]	ΔΔ [g]
DELA.1880.00	400	420

■ Simplified bevel protractor



- Stainless steel model without square.
- Accuracy: 5 mn arc.
- Length: 300 mm.
- Supplied in case (L. x D. x H.): 370 x 145 x 35 mm.



Price	L [mm]	ΔΔ [g]
DELA.1897.02	300	400

■ High precision bevel protractor

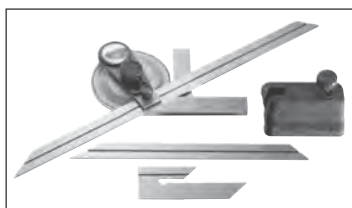

- Tempered stainless steel bevel protractor.
- Anti-reflection mat chrome reading surface.
- Measurement range 0 - 360°.
- Minimum reading: 5° arc on vernier.
- Dial diameter: 70 mm.
- Dimensions (L. x D. x H.): 315 x 75 x 20 mm.
- Dial pivots with vernier and dial locking screw.
- 2 End rules cut at 45° and 60°, including:
 - 1 short rule 200 mm x 16 mm.
 - 1 long rule 300 mm x 16 mm.
- Rule offset by 85 mm x 16 mm.
- Slide rules locking screw.
- Magnifying glass.
- Cast iron base: 70 mm x 30 mm.



Price	H [mm]	L [mm]	P [mm]	ΔΔ [kg]
813B.S	20	315	75	1,466

SCRIBER

DELA.1901 - Dry tip scriber

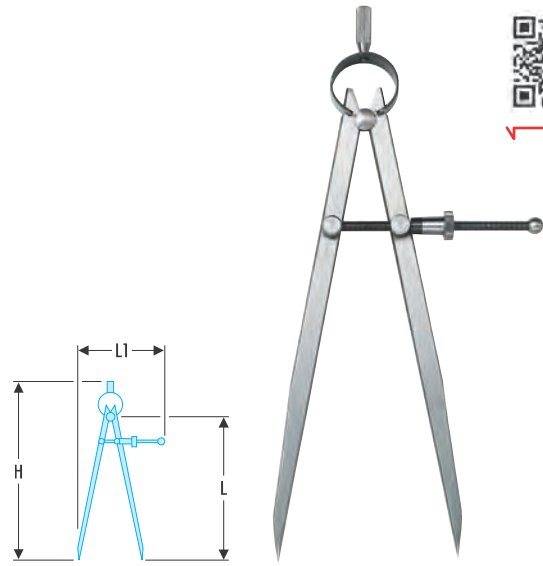

Model	H [mm]	L [mm]	L1 [mm]	ΔΔ [g]
DELA.1901.05	195	150	85	90
DELA.1901.07	245	200	100	160
DELA.1901.08	300	250	125	200

Pen holder scriber

• Pen: Ø 8 mm.

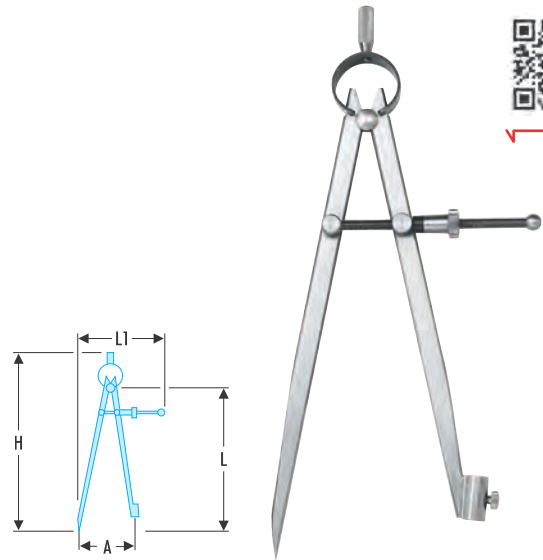

Model	A [mm]	H [mm]	L [mm]	L1 [mm]	ΔΔ [g]
DELA.1905.05	250	300	250	125	210

1/4" circle scriber

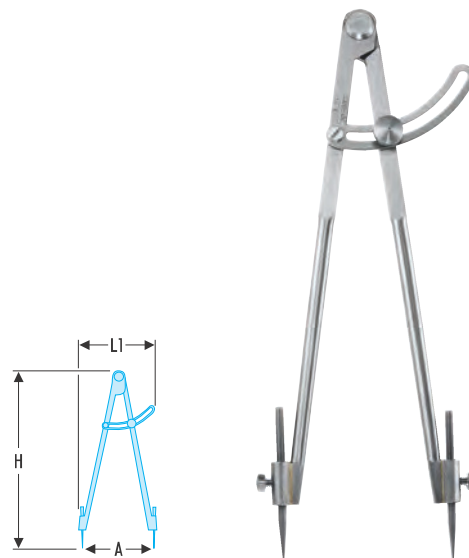

Model	A [mm]	H [mm]	L1 [mm]	ΔΔ [g]
823.25	250	250	94	370

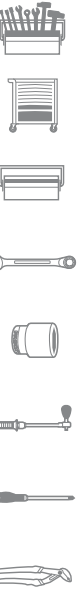

MEASURING MARKING OUT SET

Measuring marking out set



- 257G: automatic centre punch.
- 234: scriber.
- 893B.319: tape measure 3 m.
- DELA.1051.05: rule 300 mm.
- 1885.00: bevel protractor.
- DELA.1051.300: straight square and tab 300 mm.
- Thermoformed module PL633.



Icon	H [mm]	l [mm]	L [mm]	ΔΔ [kg]
MOD.234	40	175	418	1,050

STEEL SCRIBERS

Steel scriber



- Tip treated in chrome vanadium steel.
- Tip: Ø 4 mm.



Icon	L [mm]	ΔΔ [g]
234	190	20

Interchangeable steel tip scribe



- Tip treated in fast steel.
 - Tips: Ø 4 mm.
 - Body: Ø 8 mm.
- Set of 2 spare tips: 234.SP2.



Icon	L [mm]	ΔΔ [g]
234A.S	260	58

Pen type carbide scriber



- Steel hexagonal body with a staple.
- Resharpenable tip:
- Length: 12 mm.
- Ø: 2.5 mm.



Icon	L [mm]	ΔΔ [g]
DELA.1589.00A	150	100

MARKING-OUT

STEEL SCRIBERS

One-piece carbide scriber

- Rungsten carbide offset tip for scribing on tempered parts: Ø 2 mm.
- Octogon-shape body: Ø 12 mm.
- Length: 180 mm.



Icon	L [mm]	ΔΔ [g]
236	180	30

Square tips

- Square blade treated steel tip.
- Protwist ergonomic handle.
- For tapping hole, chamfering, deburring, etc.



Icon	L [mm]	Blade	Handle	ΔΔ [g]
AP6X80	190	6 x 80	30 x 110	80
AP8x125	245	8 x 125	36 x 125	120

LETTER AND DIGIT PUNCHES

292A - Set of 26 letter punches and punch

DIN 7353

- Letter heights: 3 to 8 mm.
- Carbon steel 60 HRc.
- Supplied in plastic box.



Icon	A [mm]	L [mm]	Dimension [mm]	Cross-section [mm]	ΔΔ [g]
292A.3	3	70	110 x 40 x 80	8 x 8	800
292A.4	4	70	110 x 40 x 80	8 x 8	800
292A.5	5	75	110 x 40 x 80	10 x 10	1340
292A.6	6	75	110 x 40 x 80	10 x 10	1350
292A.8	8	83	145 x 55 x 90	13 x 13	2520

293A - Set of 9 digit punches

DIN 7353

- Digit heights: 2 to 8 mm.
- Carbon steel 60 HRc.
- Supplied in plastic box.



Icon	A [mm]	L [mm]	Dimension [mm]	Cross-section [mm]	ΔΔ [g]
293A.3	2	70	40 x 40 x 80	8 x 8	265
293A.4	4	75	40 x 40 x 80	8 x 8	275
293A.5	5	75	40 x 40 x 80	10 x 10	460
293A.6	6	75	40 x 40 x 80	10 x 10	460
293A.8	8	83	55 x 55 x 90	13 x 13	925



FLUO

Rfid



GRIP SERIES

897A - HIGH PERFORMANCE TAPE MEASURE

Bi-material casing

- Soft gum coating: comfort and longevity.
- Metal plate insert.
- High strenght.

Wide hook with 3-point fastening

High quality extra wide mylar tape

- 19 mm for 3 meter measurements.
- 28 mm for 4 and 8 meters measurements.
- Extreme rigidity (up to over 3 m).
- Resistance to abrasion.

Belt clip



Locking button with automatic return



897A - ABS body tape measure Grip

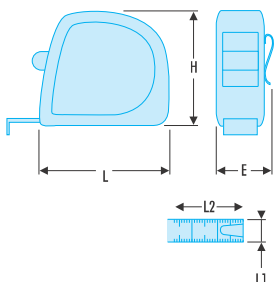

- Soft coating withstanding impacts and intense conditions of use.
- Very high durability, anti-reflection mat, Mylar coating.
- 897A.319: 2-rivet blade covering with stainless steel reinforcement plate.
- 897A.528 - 897A.828: 3-rivet blade covering with stainless steel reinforcement plate.
- Horizontal and vertical tape rigidity see dimension table.
- Stainless belt clip.



FACOM	E [mm]	H [mm]	L [mm]	L1 [mm]	L2 [m]	Rigidity Max Horizontal [m]	$\Delta\Delta$ [g]
897A.319	40	61,6	65	19	3	1,7	14
897A.528	54	71,2	74	28	5	3,1	33
897A.828	54	80,5	83,5	28	8	3,1	48

SHORT LENGTH TAPE MEASURES

ABS SERIES

893B - ABS body tape measure

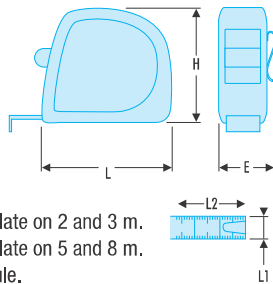

- Ergonomic, ABS material.
- Tape with mat anti-reflection nylon tape.
- High strength tape.
- High strength cover hook:
 - 2 rivets with stainless steel stiffening plate on 2 and 3 m.
 - 3 rivets with stainless steel stiffening plate on 5 and 8 m.
- Double-sided printed tape for use as a rule.

	E [mm]	H [mm]	L [mm]	L1 [mm]	L2 [mm]
893B.213	31	59,2	60	16	2
893B.319	35,2	59,2	60	16	3
893B.519	35,2	65,1	70	19	5
893B.825	42,1	78,1	80	25	8

METAL SERIES

Stainless body 2 meter tape measures

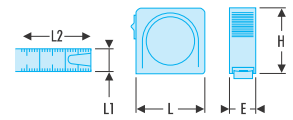
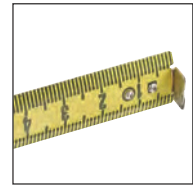

- Compact.
- Width: 16 mm.
- Tape with 2 rivets.
- Rigidity up to 1.10 m.

	A [mm]	E [mm]	H [mm]	L1 [mm]	L2 [m]	ΔΔ [g]
800A.216	50	21,4	50	16	2	90

EXPORT SERIES MM AND INCH (NOT FOR SALE IN FRANCE)

METRIC AND INCH EXPORT TAPE

- Hardened steel blade, concave for stiffness.
- Yellow background, protective coating.
- Identical casing to equivalent metric series.
- Double marking tapes are not for sale in the French territory.



ABS body tape measure - mm and inches

- Metric and imperial graduation tape measure (not for sale in France).

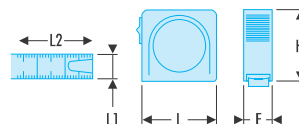

	E [mm]	H [mm]	L1 [mm]	L2 ["]	L2 [m]	ΔΔ [g]
DELA.35.00EX	33	62	16	10	3	345

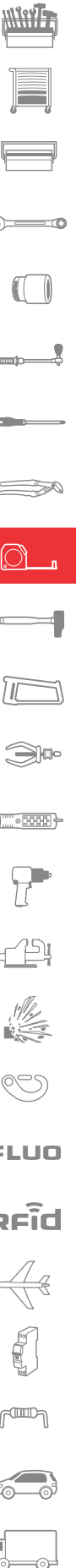

TAPE TREATED ANTICORROSION CLASS I

LONG TAPE MEASURES

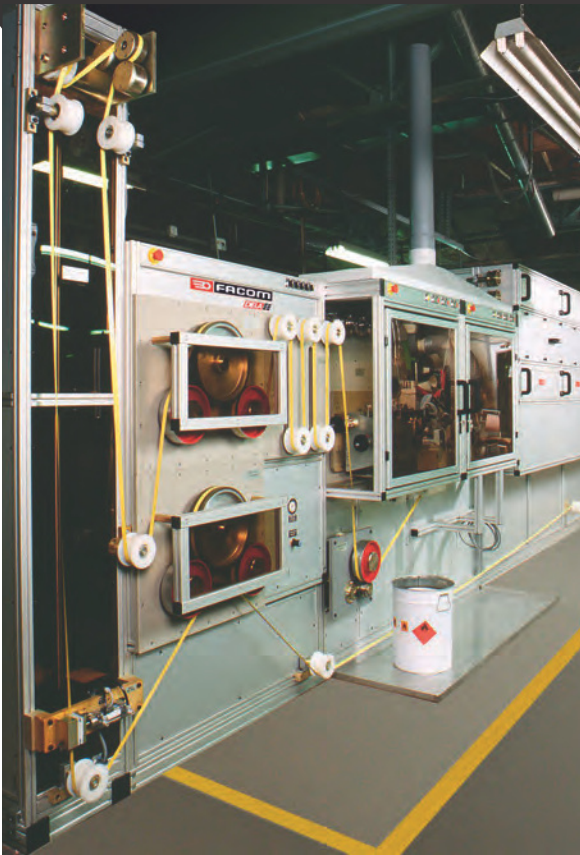

Plastiver tapes are ideal for "outdoor" applications (e.g. building sites...). Stringent inspection procedures ensure that our tapes conform to precision class I, II or III.



STEEL TAPE: Class I and II

- Hard-wearing coating
- Yellow finish
- Corrosion protection
- Hardened steel



PLASTIVER TAPE: Class III

32 glass-fibre strands coated with PVC, centimeters marked in black and metres in red for excellent readability.

CORROSION RESISTANT STEEL TAPE



Definition of class I

The particularly exacting tolerances of class I are limited to $\pm 1/10$ millimeter per metre. Class I tapes are supplied complete with a COFRAC calibration certificate. They have the "zero mark" approximately 10 cm after the beginning of the tape.

Calibration certificate

These tapes come with a COFRAC-approved calibration certificate. This certificate is in line with ISO 9000 certification procedures. - For 10m and 20m tapes, checks are made every metre. - For 30m and 50m tapes, checks are at 5-metre intervals.

■ Cutout body tape measure 20 m

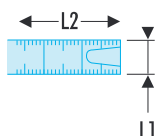

- Tape treated anticorrosion Class I.
- Lacquered steel body with folding crank.
- Tape guide rollers.
- Loop with folding hook.
- "Line" measurement, the zero starts 10 cm after the loop.



	L1 [mm]	L2 [m]	$\Delta\Delta$ [g]
DELA.62881.02C	13	20	420

LONG TAPE MEASURES

TAPE TREATED ANTICORROSION CLASS II

■ **Tape measure 50 m**

- Tape treated anticorrosion Class II.
- Revolver handle, ergonomic with folding crank.
- Loop with folding hook.
- Supplied in case dimensions (L. x D. x H.): 325 x 275 x 56 mm.

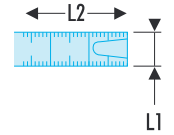

	L1 [mm]	L2 [m]	ΔΔ [g]
DELA.2883.04	13	50	240

LEVELS

ENGINEERS LEVELS

■ **Two-vial level**

- Accuracy: 0.4 mm/m.
- Dressed steel with grooves for cylindrical surfaces.
- Adjustable and protected longitudinal vial.



	L [mm]	ΔΔ [g]
DELA.3151.01	200	400

■ **Cross-test level**

DIN 877

- Stabilised cast iron level.
- Accuracy: 0.04 mm/m.
- Sides with anti-slip insulating pads.
- Vials protected by colourless plexiglas.
- Prismatic base with 140° Vee.
- Liquid: ether.
- Supplied in wood case with compliance certificate.

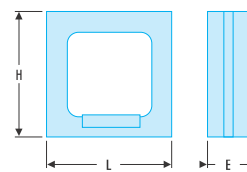

	E [mm]	H [mm]	L [mm]	ΔΔ [kg]
3071.200	42,5	200	200	4,300

■ **DELA.3180 - Round laid levels**

- Spherical vial levels.
- Checking horizontal surfaces along two axes.
- Nickel-plated brass.



	d [mm]	ΔΔ [g]
DELA.3180.03	30	20
DELA.3180.05	50	80

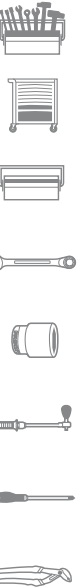

FLUO

Rfid



ENGINEERS LEVELS

3067 - High accuracy straight levels



DIN 877

- Stabilised cast iron levels.
- Accuracy: 0,04 mm/m.
- Sides with anti-slip insulating pads.
- Vials protected by colourless plexiglas.
- Prismatic base with 140° Vee.
- Liquid: ether.
- supplied in wood case with compliance certificate.

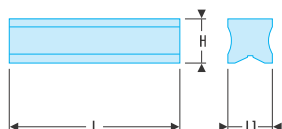

ED	H [mm]	L [mm]	L1 [mm]	ΔΔ [kg]
3067.200	42,5	200	40	1,620
3067.300	47,0	300	50	2,580

LEVELS

Easy-to-use, professional grade tools!

Accuracy

- The accuracy of a level is defined by 2 elements:
 - The quality of machining of the flat faces,
 - The quality and positioning of the vial.
- Vial integral with the body of the level.

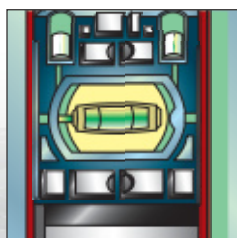

Readability

- Vial machined from a solid acrylic block:
 - Anti-reflective.
 - Anti-parallax.
- Does not become clouded over time.
- High impact resistance.

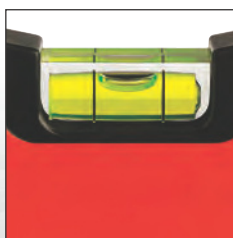

Durability

- Unbreakable synthetic caps.
- Impact-protection system providing maximum protection to the face.
- Rigid.
- Leak proof and highly impact-resistant acrylic glass.



TRAPEZOIDAL LEVELS

307BM - Magnetic trapezoidal levels



DIN 877

- In reverse position, accuracy 0,75 mm/m.
- Massive light alloy body, pressure moulded.
- Electrostatic powder protective coating.

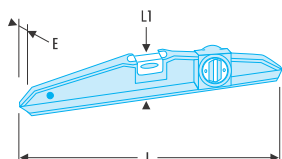

ED	E [mm]	L [mm]	L1 [mm]	ΔΔ [g]
307BM.25	22	250	45	200
307BM.40	23	400	50	420
307BM.60	23	600	50	500

307B - Standard trapezoidal levels

DIN 877

- In reverse position, accuracy 0.75 mm/m.
- Massive light alloy body, pressure moulded.
- Electrostatic powder protective coating.



Model	E [mm]	L [mm]	L1 [mm]	ΔΔ [g]
307B.25	22	250	45	200
307B.40	23	400	50	420
307B.60	23	600	50	680

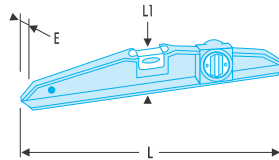

TUBULAR-SECTION LEVELS

320B - Standard levels, 1 machined sole plate

DIN 877

- In reverse position, accuracy 0.75 mm/m.
- Light alloy body, drawn.
- Electrostatic powder coating.
- Vertical vial and horizontal vial.



Model	E [mm]	L [mm]	L1 [mm]	ΔΔ [g]
320B.40	21	400	50	96
320B.60	21	600	50	106

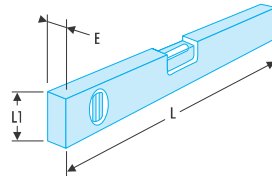

309BM - Magnetic levels

DIN 877

- In reverse position, accuracy 1 mm/m.
- Light alloy body, drawn.
- Smooth anodized surfaces (easy cleaning).
- Vertical vial and horizontal vial.



Model	E [mm]	L [mm]	L1 [mm]	ΔΔ [g]
309BM.40	21	400	50	300
309BM.60	21	600	50	80

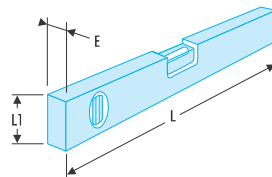

311B - Magnetic levels, 1 machined sole plate

DIN 877

- In reverse position, accuracy 0.5 mm/m.
- Fitted with a vertical vial, horizontal vial, and a declivity vial.



Model	E [mm]	L [mm]	L1 [mm]	ΔΔ [g]
311B.60	25	600	54	184
311B.80	25	800	54	378

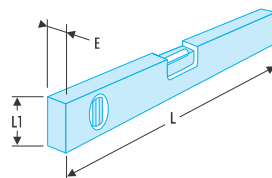

SYNTHETIC FOLDING RULE

■ Synthetic blade rule Class III 2 meters - 10 branches



- Recto verso graduatiron on the 2 edges in mm.
- Clicked branches 90° or 180°.
- Washable.



Width l [mm]	$\Delta\Delta$ [g]
DELA.401.00 16	105

BUILDERS SQUARES

SQUARES

■ DELA.1223 - Stainless steel joiners squares

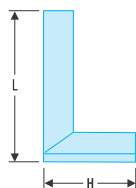
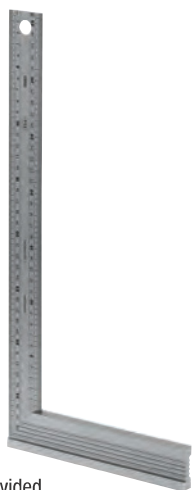

NF E 73-205

- Stainless steel blade divided in recto-verso protected by a sleeve.
- Anti-reflection.
- Deep engravings.
- Anodised aluminium heel.

H [mm]	L [mm]	$\Delta\Delta$ [g]
DELA.1223.01 120	200	160
DELA.1223.02 140	250	200
DELA.1223.03 170	300	240
DELA.1223.04 200	400	300

FALSE SQUARES

■ DELA.1208 - Dummy squares and dummy sliding squares

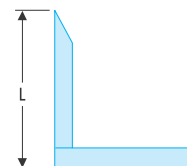

- Wood heel, steel blade, brass lining.
- 1208: sliding dummy square

L [mm]	$\Delta\Delta$ [g]
DELA.1208.02 250	120
DELA.1208.03 300	140

BUILDERS MARKING-OUT

■ Plumb-bob



- Engineers plumb-bob.
- Diameter: 16 mm.
- Supplied with 4 m \varnothing 2 mm line.



$\Delta\Delta$ [g]
DELA.3224.00 125

CHALK LINE REELS

▪ **DELA.3298 - Chalk line reels, plum-bob**

- Metal container with chalk line locking by folding the crank.
- Chalk line reel: Ø 1.5 mm.

DE	L [m]	ΔΔ [g]
DELA.3298.15	15	65
DELA.3298.30	30	80



▪ **DELA.13299 - Profile chalk line reels**



- Ergonomic alu body, anti-wear wire guide.
- Fast winding.
- Polycotton line Ø 1mm with hook.
Spare line 100 m: DELA.3226.01.CORD.

DE	L [m]	ΔΔ [g]
DELA.13299.15	15	125
DELA.13299.30	30	265



▪ **Grodel chalk line reel**



- Builders carcass and public works.
- High strength synthetic body with folding crank.
- High capacity container.
- Chalk line reel: Ø 3 mm.

DE	L [m]	ΔΔ [g]
DELA.3400.00	30	140



CHALK STICKS

▪ **Natural "Briançon" chalk sticks**

- Natural cut greasy chalk for marking on metal.
- Cross-section: 10 x 10 mm.
- Length: 100 mm.
- Colour: white.
- Box of 50 units.

DE	L [mm]	ΔΔ [g]
DELA.3310.00	100	1300

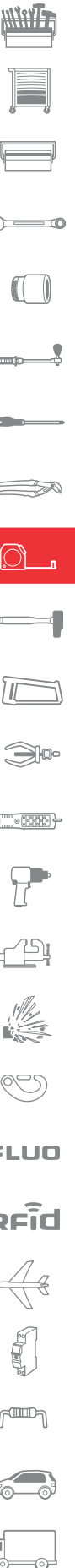

FLUO

RFid

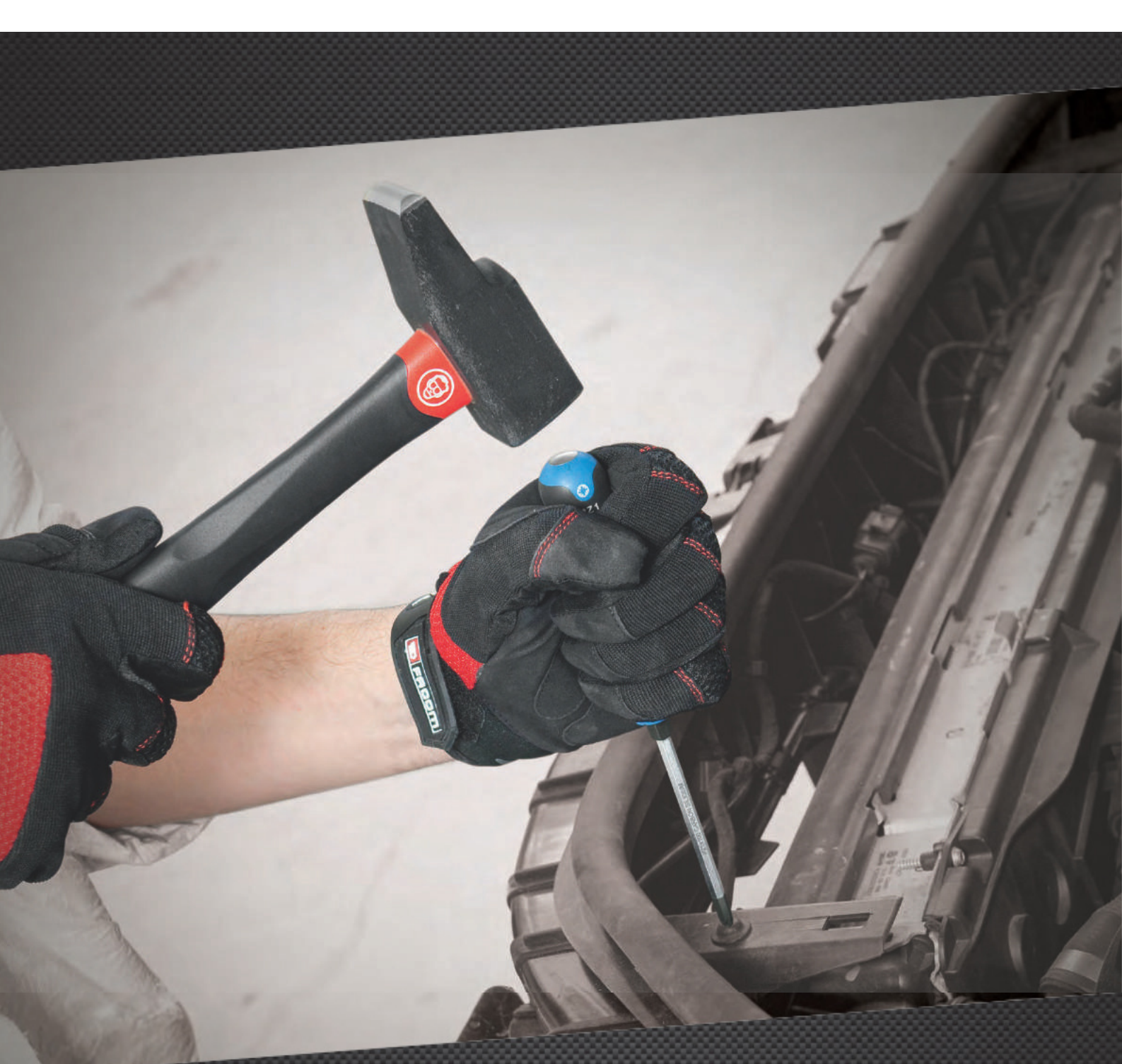

HAMMERS - IMPACT TOOLS



**HAMMERS -
SLEDGE HAMMERS**

Graphite handle hammer
Hickory handle hammers

560

560
562



CLUB HAMMERS

Dead-blow hammers
Adaptable-tip mallets
Punches and nail sets

567

567
568
570



IMPACT TOOLS

Multi-impact tool sets
Sheathed series
Drifts
Nail sets
Flat chisels - Cape chisels

571

571
572
575
577
578



**IMPACT
TOOLS MODULES**

Impact tools modules

580

580



FLUO

Rfid



HAMMER WITH GRAPHITE HANDLE



The safe hammer

A combination of 3 materials for a perfect result

- 1 - Graphite:**
For strength. No risk of breakage.
- 2 - Polypropylene:**
For reduced vibration.
- 3 - Elastomer:**
For a perfect grip and excellent resistance to corrosive workshop liquids.

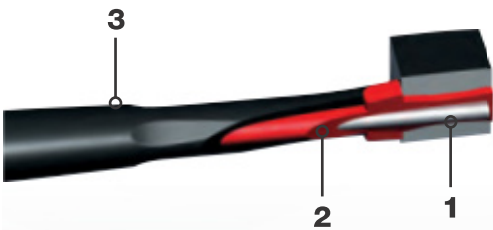

200 C



205 C



Maximum safety.
• Permanent epoxy resin head-to-handle connection Unbreakable.

Total comfort
• Anti vibration : absorbent material and narrow upper handle profile to reduce vibration.

Positive grip
• Soft elastomer handle for a comfortable hold.
• Wide guard to prevent loss of grip.

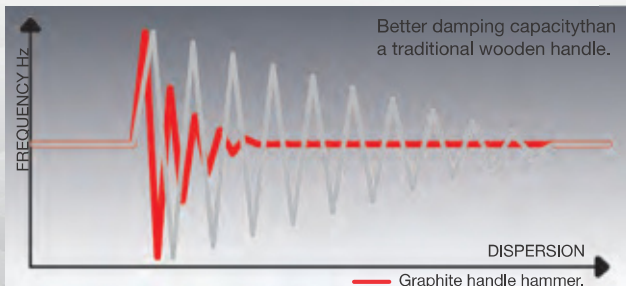

SAFETY FIRST
Wear eye protection.



GRAPHITE HANDLE HAMMER

200C - Graphite handle riveting engineers hammer

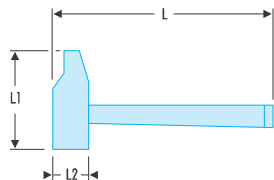
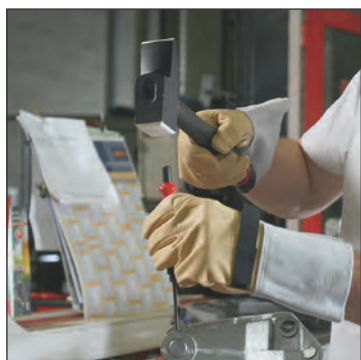

NF ISO 15601, ISO 15601

• Ergonomic safety handle with graphite core.

Ref	L [mm]	L1 [mm]	L2 [mm]	ΔΔ [g]
200C.26	245	80	25	345
200C.28	270	88	28	380
200C.30	270	93	30	470
200C.32	300	100	32	585
200C.36	300	106	35	725
200C.40	330	108	40	1000
200C.42	330	117	42	1100
200C.50	360	138	50	1900
200C.60	380	151	60	2800

205C - Graphite handle DIN engineers hammer

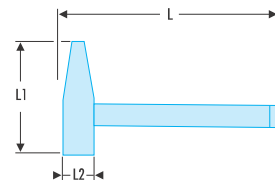

NF ISO 15601, ISO 15601, DIN 1041

• Ergonomic safety handle with graphite core.

Ref	L [mm]	L1 [mm]	L2 [mm]	ΔΔ [g]
205C.20	280	96	19	250
205C.30	300	106	23	380
205C.50	320	122	27	580
205C.80	350	132	33	960
205C.100	360	137	36	1200

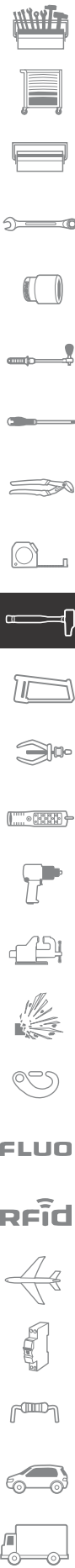

WOOD HANDLE HAMMER

Safe, ergonomic and comfortable

HEAD.
"High security" triple wedge handle attachment:

- 2 steel + 1 wooden wedge for a better distribution of contact surfaces between the handle and the head.

Head very firmly secured on the handle:

- Precise heat treatment of the head for ultimate safety and durability.

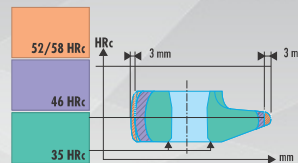

HANDLE.
Hickory:

- Excellent mechanical strength. Unaffected by climatic differences.

Octagonal handle profile:

- Exclusive to FACOM. Best compromise between mechanical strength and absorption of vibration.



Growth ring

Our handles are made only from blocks with a strictly defined number of growth rings : as this determines the rate of growth of the tree. Fast growth, few rings, low density wood and thus low mechanical strength.



- Always inspect a hammer before use. If damaged in any way, discard it.
- Watch out for:
 Excessively worn or mushroomed head.
 Suspect fit.
 Scored handle.
- For safety, the hammer should hit dead square in the centre of the face. Steady precise blows extend tool life. Flying chips are dangerous.
- Never hammer materials harder than 46 HRc. Use a FACOM mallet instead.

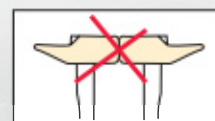
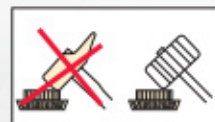
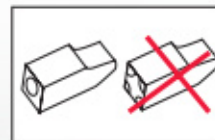
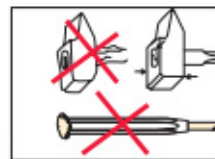

Safety first

Wear eye protection



202H - Ball head engineers hammers

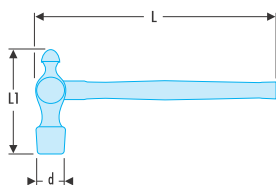

NF ISO 15601, ISO 15601, ASME B107.400
 • "High safety" hickory handle, steel wedge.



Ref	d [mm]	L [mm]	L1 [mm]	Handle	$\Delta\Delta$ [g]
202H.1/4	20	275	65	210.MHB07	140
202H.1/2	26	297	84	210.MHB08	280
202H.1	31	322	104	210.MHB09	430
202H.1'1/2	37	363	123	210.MHB10	840
202H.2	40	394	128	210.MHB11	1100

860H - Dinging hammers, round face

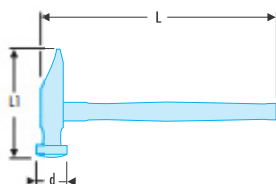

NF ISO 15601, ISO 15601
 • "High safety" hickory handle, triple fit:
 2 steel wedges and 1 wood wedge.



Ref	d [mm]	L [mm]	L1 [mm]	Handle	$\Delta\Delta$ [g]
860H.26	26	297	114	210.MHB26	340
860H.28	28	297	118	210.MHB26	370
860H.30	30	314	123	210.MHB28	440
860H.32	32	339	134	210.MHB29	570
860H.36	36	339	139	210.MHB29	700
860H.40	40	377	149	210.MHB31	920

Dinging hammer, square face

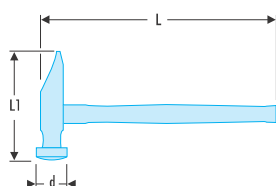

NF ISO 15601, ISO 15601
 • "High safety" hickory handle, triple fit:
 2 steel wedges and 1 wood wedge.



Ref	d [mm]	L [mm]	L1 [mm]	Handle	$\Delta\Delta$ [g]
859H.28	28	319	140	210.MHB34	560

213H - Welders chipping hammers

NF ISO 15601, ISO 15601, DIN 6465

- "High safety" hickory handle, triple fit: 2 steel wedges and 1 wood wedge.

ED	L [mm]	L1 [mm]	L2 [mm]	Handle	ΔΔ [g]
213H.30	270	170	21	210.MHB32	340
213H.40	270	180	21	210.MHB32	480

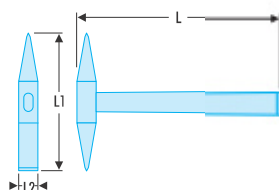

203H - Electricians hammer

NF ISO 15601, ISO 15601

- "High safety" hickory handle, triple fit: 2 steel wedges and 1 wood wedge.

ED	L [mm]	L1 [mm]	L2 [mm]	ΔΔ [g]
203H.16	237	141	16	160
203H.18	237	142	18	200

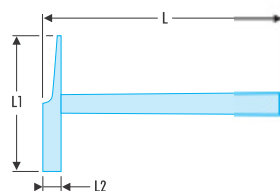

215H - Joiners hammers

NF ISO 15601, ISO 15601

- "High safety" hickory handle, triple fit: 2 steel wedges and 1 wood wedge.

ED	L [mm]	L1 [mm]	L2 [mm]	ΔΔ [g]
215H.20	264	91	20	210
215H.22	283	99	22	270
215H.26	285	109	26	360

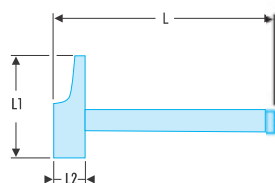

FLUO

Rfid



■ **Carpenters hammer**

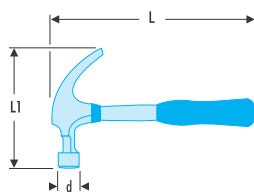

ASME B107.400

- Safety fit tubular handle, PVC grip.
- Head balanced with nail-puller peen.
- Presentation: polished finish.

➤	d [mm]	L [mm]	L1 [mm]	ΔΔ [g]
204	30	335	130	810

■ **High load club hammer**

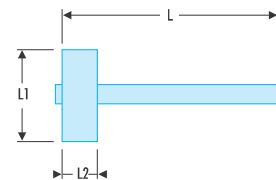

■ **1262H - Beveled edge club hammers**

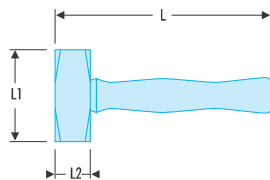

NF ISO 15601, ISO 15601, DIN 6475

- "High safety" hickory handle, triple fit: 2 steel wedges and 1 wood wedge.

➤	L [mm]	L1 [mm]	L2 [mm]	Handle	ΔΔ [kg]
1262H.100	245	100	40	210.MHB22	1.0
1262H.125	248	105	43	210.MHB23	1.3
1262H.150	254	115	45	210.MHB24	1.5

NF ISO 15601, ISO 15601, DIN 6475

- "High safety" hickory handle.

➤	H [mm]	L [mm]	L1 [mm]	L2 [mm]	Handle	ΔΔ [kg]
1263H.400	60	880	175	60	210.MHB35	4.8

DEAD-BLOW HAMMERS

DEAD-BLOW HAMMERS

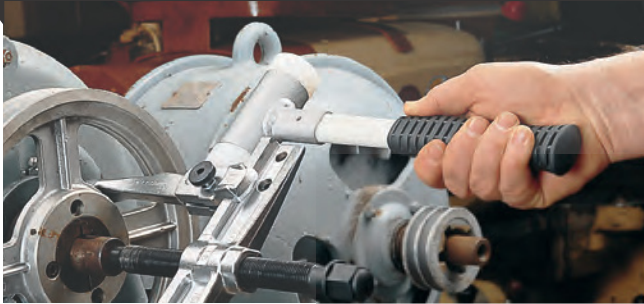

Safe, ergonomic and comfortable

Deadening the blow

The head is half-filled with steel balls, the mass of which has sufficient inertia to counteract any tendency to bounce back. After striking, the face of the hammer remains in position, without the damaging effects of rebound when hammering home an accurate fit. The nylon or polyurethane striking faces remove the risk of lying chips when hitting hard metal objects.



"Monobloc" hammer in polyurethane

- In addition to the dead-blow feature the soft-face hammer 216 is fully moulded in a polyurethane shell.
- This monobloc design protects the head from splitting and the balls escaping in the workshop.
- The chemical-resistant polyurethane moulding gives the tips a far longer service life than conventional soft-faced hammers.

Steel body and handle

Steel balls

Reinforced striking area

Polyurethane moulding

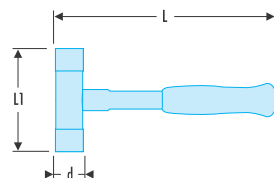

- Dead-blow hammer with steel microballs.
- Body and handle in steel coated with polyurethane.
- D45 ± 5 shore hardness impact surface.
- Ergonomic PVC grip.

Model	d [mm]	L [mm]	L1 [mm]	ΔΔ [g]
216.40	40	298	110	657
216.50	50	308	115	888
216.60	60	316	120	1300

212A - Dead-blow hammers, interchangeable tips

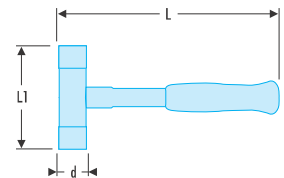

- Fiberglass handle.
- Steel body.
- Easily replaceable, special nylon tips shore hardness D74 ± 5.
- Ergonomic PVC grip.
- Presentation: black epoxy.
- Spare tip: 212.E35 to E60.

Model	d [mm]	L [mm]	L1 [mm]	ΔΔ [g]
212A.35	35	305	112	700
212A.40	40	310	117	840
212A.50	50	320	120	1200
212A.60	60	330	145	1700

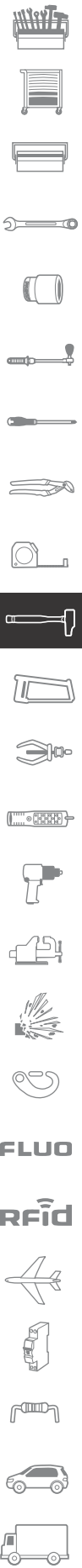

ADAPTABLE-TIP MALLETS

INTERCHANGEABLE-TIP MALLETS

Impact tool safety

- Check the condition of the tool before use.
- Do not use tools with traces of wear, mushrooming, scaling or cracks.
- Wear eye protection and gloves.



207A-208A - Adaptable-tip mallets



- 207A: Aluminum body "light" series hammers.
- 208A: Steel body "heavy" series hammers.
- Mallets are available with a limited number of tip combinations only, but you can customize your mallet by selecting a body and two tips of your choice.
- Tips available:
 - EA series: neoprene.
 - EB series: polyurethane.
 - EC series: nylon.

ED	d [mm]	Bits	Finish	$\Delta\Delta$ [kg]
207A.25CB	25	EC - EB	Aluminium	0,135
207A.32CB	32	EC - EB	Aluminium	0,210
207A.40CB	40	EC - EB	Aluminium	0,350
207A.50CB	50	EC - EB	Aluminium	0,560
207A.60CB	60	EC - EB	Aluminium	0,840
208A.25CBA	25	EC - EB	Brass	0,220
208A.32CBA	32	EC - EB	Brass	0,345
208A.32BBA	32	EB - EB	Brass	0,350
208A.40CBA	40	EC - EB	Brass	0,615
208A.40CCA	40	EC - EC	Brass	0,620
208A.50CBA	50	EC - EB	Brass	1,000
208A.60CBA	60	EC - EB	Brass	1,550

207A-208A - Mallet tips

- 207A: Lightweight aluminum body, hickory handle.
- 208A: Heavyweight steel body, hickory handle.



ED	d [mm]	L [mm]	Handle	Finish	ΔΔ [g]
207A.25	25	280	210.MHB12	Aluminium	110
207A.32	32	300	210.MHB13	Aluminium	160
207A.40	40	323	210.MHB14	Aluminium	270
207A.50	50	350	210.MHB15	Aluminium	410
207A.60	60	363	210.MHB16	Aluminium	610
208A.25A	25	280	210.MHB12	Brass	200
208A.32A	32	300	210.MHB13	Brass	295
208A.40A	40	323	210.MHB14	Brass	510
208A.50A	50	350	210.MHB15	Brass	830
208A.60A	60	363	210.MHB16	Brass	1300

EA-EB-EC - Spare tips for mallets

- Tips:
 - EA: neoprene tips, hardness shore A75. Replaces rubber mallets.
 - EB: thermoplastic polyurethane tips (TPU), hardness shore D56. Replaces wood and leather mallets.
 - EC: nylon tips, hardness shore D68. Replaces soft metal mallets (copper, lead, brass, aluminum).

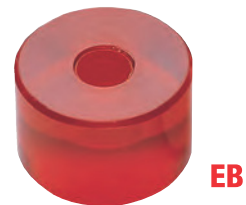

ED	d [mm]	Color	Bits
EA.25	25	Black	Neopreen
EA.32	32	Black	Neopreen
EA.40	40	Black	Neopreen
EA.50	50	Black	Neopreen
EA.60	60	Black	Neopreen
EB.25	25	Red	TPU
EB.32	32	Red	TPU
EB.40	40	Red	TPU
EB.50	50	Red	TPU
EB.60	60	Red	TPU
EC.25	25	White	Nylon
EC.32	32	White	Nylon
EC.40	40	White	Nylon
EC.50	50	White	Nylon
EC.60	60	White	Nylon

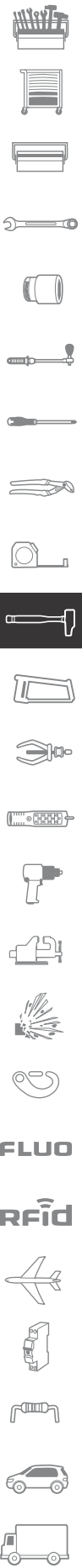

PUNCHES AND NAIL SETS

214 - Standard drifts



- Steel body.
- Replaceable nylon tips shore hardness D74.
- Use with a hammer or by hand to fit or extract small parts or bearings.
- Replaces bronze or brass drifts.



	d [mm]	L [mm]	Bits	ΔΔ [g]
214.10	10	166	212.E10	100
214.15	15	175	212.E15	200

214.R - Dead-blow drifts



- Steel body with dead-blow design: the body is filled with steel balls preventing rebound after the shock.
- Replaceable nylon tips shore hardness D74.
- These large drifts can be used directly by hand to place parts delicately.



	d [mm]	L [mm]	Bits	ΔΔ [g]
214.R20	20	150	212.E20	220
214.R25	25	153	212.E25	330
214.R30	30	157	212.E30	460
214.R35	35	157	212.E35	620

MULTI-IMPACT TOOL SETS

MULTI-IMPACT SYSTEM



Drifts and punches

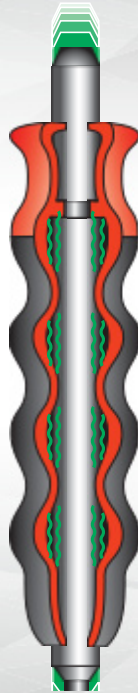

Parts protection

- Interchangeable tips of different hardness for parts that must not be marked.
- High quality, precision tools.

Multi-solution

- Tips of 3 different materials: brass, aluminium and polyamide.
- Extensive range of sizes.

Comfort and safety

- Exclusive sheathed, shock-absorbing handle.
- Slide-action for an increased shock-absorbency.
- Positive grip.



Drifts set - 3 materials: Brass-Polyamide-Aluminum

- Capacity Ø 10 to 20 mm.
- Sets of 19 pieces comprising:
 - 1 anti-vibration sheathed grip 217.G16.
 - 5 aluminum drift punch tips Ø 10, 12, 14, 16, 18 mm; useful length: 60 mm.
 - 3 brass tips Ø 12, 16, 20 mm; useful length: 40 mm.
 - 3 polyamide tips Ø 12, 16, 20 mm; useful length: 40 mm.
 - one extension useful length 100 mm.
 - 3 bits for extension: brass Ø 12, 16, 18 mm; useful length: 20 mm.
 - 3 bits for extension: polyamide Ø 12, 16, 18 mm; useful length: 20 mm.
- Packaged in plastic case 265 x 230 x 50.



217.GJ1	H [mm]	L [mm]	l [mm]	ΔΔ [kg]
	50	265	230	1.4

Extension

- M8 threaded bit holder extension.

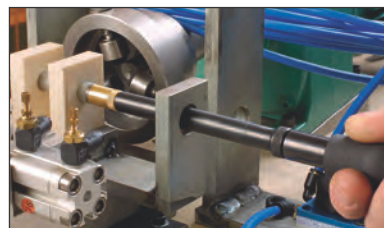

217.R12	d [mm]	L [mm]	ΔΔ [g]
	12	125	105



SHEATHED SERIES

SHEATHED SERIES - A STEP FORWARD



New ultra-comfortable anti-roll sheath



Ergonomic

- Shock-absorbing.
- Elastic sheath.
- Partly free-sliding sheath.
- More stable, more positive grip.
- Protects the hand.

Safe

- Choice of best steels.
- Very precise heat treatment with different harnesses. DIN 7255. FACOM specifications.
- Better shock absorbance and elasticity to avoid the risk of breakage.

Precise and Powerful

- Comfortable grip ensures an accurately aimed blow.
- Stability of tool ensures a more powerful blow.

249G - Sheathed drift punches

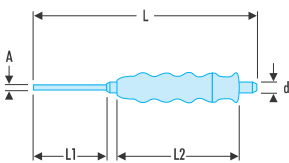

- Long shank.
- Head hardened to 43 HRc.
- Shank hardened to 58 HRc.



➤	A [mm]	d [mm]	L [mm]	L1 [mm]	L2 [mm]	ΔΔ [g]
249.G2	1,95	8	140	35	105	88
249.G3	2,95	8	150	45	105	90
249.G4	3,95	10	190	60	105	94
249.G5	4,95	10	200	70	105	98
249.G6	5,90	12	210	80	105	142
249.G8	7,90	12	216	86	105	158
249.G10	9,80	14	230	100	105	181
249.G12	11,80	16	280	130	105	380
249.G14	13,80	18	290	140	105	490
249.G16	15,70	18	310	160	105	580

247G - Sheathed nail sets

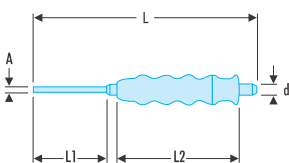

- Head hardened to 36 - 44 HRc.
- Tip hardened to 52 - 60 HRc.



➤	A [mm]	d [mm]	L [mm]	L1 [mm]	L2 [mm]	ΔΔ [g]
247.G2	1,9	10	185	55	105	102
247.G3	2,9	10	185	55	105	106
247.G4	3,9	10	185	55	105	109
247.G5	4,9	10	185	55	105	112
247.G6	5,9	10	185	55	105	115
247.G8	7,8	12	185	55	105	173

255G - Sheathed centre punches

- Head hardened to 36 - 44 HRc.
- Tip hardened to 57 - 60 HRc.



Model	A [mm]	d [mm]	L [mm]	L1 [mm]	L2 [mm]	ΔΔ [g]
255.G2,5	2,5	10	185	55	105	104
255.G4	4	10	185	55	105	110
255.G6	6	10	185	55	105	116
255.G8	8	12	185	55	105	174
255.G10	10	14	185	55	105	210

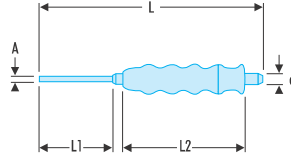

249.6 - Sets of sheathed impact tools

- Sets of punches and nail sets.

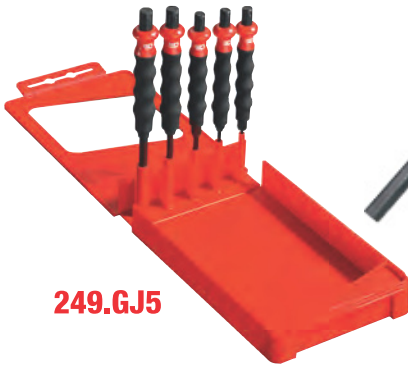

249.GJ5



249.GJ7



249.GJ4

Model	Content set
249.GJ5	249.G3 - G4 - G5 - G6 - G8
249.GJ7	249.G2 - G3 - G4 - G5 - G6 - G8 - G10
249.G2476J12	249.G2 - G3 - G4 - G5 - G6 - G8 247.G2 - G3 - G4 - G5 - G6 - G8
249.GJ4	249.G10 - G12 - G14 - G16

Sheathed drift punches module



- Comprising:
 - 249.G 2 - 3 - 4 - 5 - 6 - 8 mm: 6 drift punches.
 - 247.G 4 - 5 - 6 - 8 mm: 4 nail sets.
 - 255.G 6: punch.

Model	H [mm]	L [mm]	Content	ΔΔ [kg]
MOD.CG	40	418	Tray PL.334	1.5

Drift punch - chisels - sheathed cape chisel module



- Comprising:
 - 249.G 12 - 14 - 16 mm: 3 sheathed drift punches.
 - 263.G 19 - 20 - 22: 3 sheathed chisels.
 - 265.G 18: 1 sheathed cape chisel.

Model	H [mm]	L [mm]	Content	ΔΔ [kg]
MOD.CG1	40	418	Tray PL.611	3.0



SHEATHED SERIES

SHEATHED SERIES

Impact tool safety

- Check the condition of the tool before use.
- Do not use tools with traces of wear, mushrooming, scaling or cracks.
- Wear eye protection and gloves.



Sheathed automatic centre punch

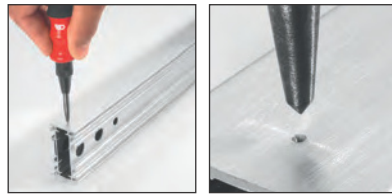

- Simply press the end to release spring impact.
- Impact adjustable from 15 to 25 kg.
- Ergonomic Facom handle.
- Tip hardened to 57 - 60 HRc.



Part Number	Weight [g]
257.G	175

263.G - Sheathed chisels

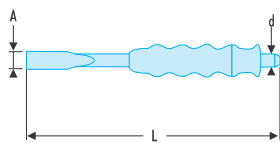

- Engineers chisels.
- Hardness:
 - Tip hardened to 57 - 60 HRc.
 - Head hardened to 36 - 44 HRc.
- Cutting angle: 60°.



Part Number	A [mm]	d [mm]	L [mm]	Weight [g]
263.G19	15	12	190	165
263.G20	20	16	200	305
263.G22	25	18	220	415

Sheathed cape chisels

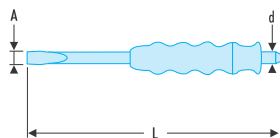

- Hardness:
 - Edge: 57-60 HRc.
 - Impact head: 36- 44 HRc.



Part Number	A [mm]	d [mm]	L [mm]	Weight [g]
265.G18	10	10	180	110

Set of sheathed tools

- Comprising:
 - 3 chisels: 263.G19 - 20 - 22.
 - 1 cape chisel: 265.G18.
- Supplied on cardboard box.



Code	ΔΔ [kg]
263.GJ4	1.0

Sheathed drift punches foam module

- Comprising:
 - 249.G 2 - 3 - 4 - 5 - 6 - 8 mm: 6 drift punches.
 - 247.G 4 - 5 - 6 - 8 mm: 4 nail sets.
 - 255.G6: punch accuracy 6 mm.

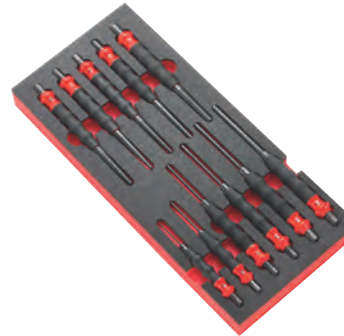

Code	H [mm]	L [mm]	Content	ΔΔ [kg]
MODM.CG	45	418	Tray PM.MODCG	1.5

DRIFTS

249 - Standard drift punches

NF E 71-211, DIN 6450, ASME B107.410

- Hexagonal shank, high-strength steel tip, hardened to 53-58 HRc.
- Zinc-plated finish.



Code	A [mm]	d [mm]	L [mm]	L1 [mm]	ΔΔ [g]
249.2	1,9	8	115	30	30
249.3	2,9	8	125	40	35
249.4	3,9	10	150	50	65
249.5	4,9	10	165	50	75
249.6	5,9	12	180	50	120
249.8	7,9	12	200	50	160
249.10	9,9	16	200	50	220

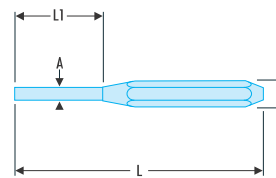

248 - One-piece drift punches

NF E 71-211, DIN 6450

- Octagon-shaped, high-strength steel tip, hardened to 53-55 HRc.
- Zinc-plated finish.



Code	A [mm]	d [mm]	L [mm]	L1 [mm]	ΔΔ [g]
248.2	1,9	8	150	30	45
248.3	2,9	8	150	40	50
248.4	3,9	10	150	50	55
248.5	4,9	10	150	50	65
248.6	5,9	10	150	50	70
248.8	7,9	12	150	50	100
248.10	9,9	12	150	50	120

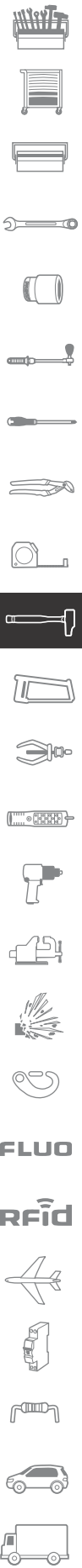
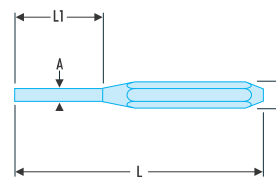

246 - Drift punches for spring pins

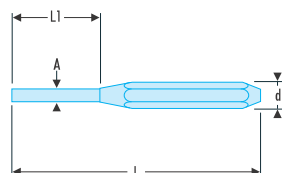

- Octagon-shaped body.
- Zinc-plated finish.
- Shouldered tip accurately centers into split pins.
- Hardened to 53 to 58 HRc guaranteeing perfect absorption of the shockwave.



ED	A [mm]	d [mm]	L [mm]	L1 [mm]	ΔΔ [g]
246.2	1,9	8	150	30	45
246.3	2,9	8	150	40	45
246.4	3,9	10	150	50	60
246.5	4,9	10	150	50	60
246.6	5,9	10	150	50	70
246.8	7,9	12	150	50	100

251A - Precision sleeved drift punches

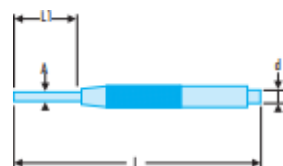
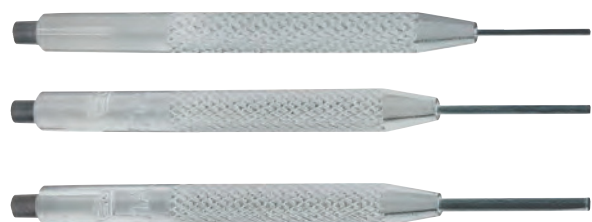

- The centre slides within a guide to prevent distortion, even in smaller sizes.
- Shank hardened to 52 to 57 HRc.
- Zinc-plated body, burnished body.



ED	A [mm]	d [mm]	L [mm]	L1 [mm]	ΔΔ [g]
251A.1	0,9	3	70	14	5
251A.1,5	1,4	3,5	83	21	10
251A.2	1,9	3,5	88	26	10
251A.2,5	2,4	4,5	93	22	18
251A.3	2,9	4,5	93	22	20
251A.3,5	3,4	5,5	96	25	25
251A.4	3,9	5,5	96	28	30
251A.5	4,9	7	107	33	45
251A.6	5,9	9	112	36	65

SETS

Impact tools set



- JS Presentation on holder.
- JT Presentation as roll sets.



ED	Content set	Dimension [mm]	Quantity	ΔΔ [g]
249.JS7	249.2-3-4-5-6-8-10	120x195x45	7	868
249.JT7	249.2-3-4-5-6-8-10	230x120	7	755
248.JS6	248.2-3-4-5-6-8	120x190x45	6	588
248.JT7	248.2-3-4-5-6-8-10	265 x 120	7	695
246.JS6	246.2-3-4-5-6-8	120x190x45	6	593
246.JT6	246.2-3-4-5-6-8	200x165	6	545
251A.JS9	251A.1-1.5-2-2.5-3-3.5-4-5-6	120x115x45	9	354
251A.JT9	251A.1-1.5-2-2.5-3-3.5-4-5-6	180 x 120	9	260
247.249JS12	247.2-3-4-5-6-8 / 249.2-3-4-5-6-8	120x180x47	12	1000
247.265JT10	247.3-4-5 / 256.4-6 / 249.3-4-5 / 263.20 / 265.18	180x120 / 240x60	10	1200

NAIL SETS

247 - Nail sets

- Octagon-shaped body.
- Shank hardened to 54 - 58 HRc.
- Zinc-plated finish.



Ref	A [mm]	d [mm]	L [mm]	L1 [mm]	ΔΔ [g]
247.2	2	10	120	40	62
247.3	3	10	120	40	63
247.4	4	10	120	40	65
247.5	5	10	120	40	65
247.6	6	10	120	40	70
247.8	8	12	120	40	100

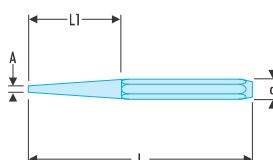

DRIFT PUNCHES

256 - Precision centre punches

- Chrome-vanadium steel forged, hardened to 52 to 58 HRc.
- Presentation: knurled body.
- Zinc-plated finish.



Ref	A [mm]	d [mm]	L [mm]	ΔΔ [g]
256.2,5	2,5	7	100	25
256.4	4	8	105	35
256.6	6	10	115	60
256.8	8	12	130	100
256.10	10	14	130	135

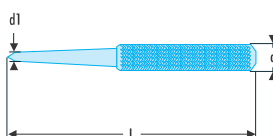

Automatic centre punch

- Simply press the end to release spring impact.
- Impact adjustable by turning the knurled head.
- Acceptable load: 11 to 22 kg.
- Presentation: chrome body, greased tip.
- Length: 163 mm, body Ø 16 mm, shank Ø 7 mm.
- Interchangeable tip: 257.07.
- Spare tip: 257.10A.

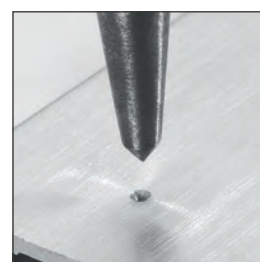

Ref	L [mm]	ΔΔ [g]
257A	163	135

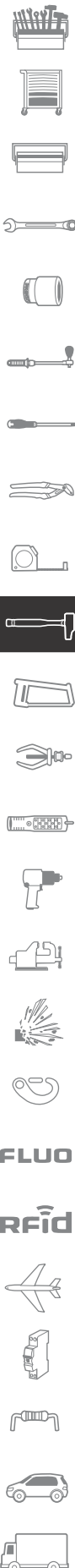

FLAT CHISELS - CAPE CHISELS

263 - Slim chisels

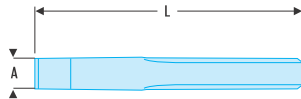

- Constant-profile cape chisel
- Chrome vanadium forged steel; differentiated heat treatment - edge 54 - 58 HRC - impact head 38 - 46 HRC to prevent head effect.
- Edge resharpening with grinder.
- Presentation: lacquered.

Ref	A [mm]	L [mm]	ΔΔ [g]
263.15	21	150	200
263.18	21	180	250
263.20	24	200	350
263.22	24	220	380
263.25	27	250	500
263.30	27	300	610

263P - Chisels with guard



- Chisels with guard, diameter: 85 mm.
- Chrome vanadium forged steel; differentiated heat treatment: edge 54 - 58 HRC - impact head 38 - 46 HRC to prevent head effect.
- Edge resharpening with grinder.
- Presentation: lacquered.

Ref	A [mm]	L [mm]	ΔΔ [g]
263.P25	27	250	610
263.P30	27	300	710

Slim-profile chisels

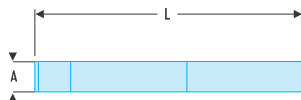

- Slim profile chisel.
- Chrome vanadium forged steel, treated 57 HRC on edge and 40 HRC on impact head.
- Blade width: 26 mm.
- Length: 235 mm.
- Presentation: lacquered.

Ref	L [mm]	ΔΔ [g]
259	235	240

Slim-profile chisel with guard



- Chisel with guard, diameter: 85 mm.
- Chrome vanadium forged steel, treated 57 HRC on edge and 40 HRC on impact head.
- Blade width: 26 mm.
- Length: 235 mm.
- Presentation: lacquered.

Ref	L [mm]	ΔΔ [g]
259.P	235	400

265 - Cape chisels



- Constant-profile cape chisels.
- Chrome vanadium forged steel; differentiated heat treatment: edge 54 - 58 HRC - impact head 38 - 46 HRC to prevent head effect.
- Edge resharpening with grinder.
- Presentation: lacquered.

Item	A [mm]	L [mm]	ΔΔ [g]
265.18	8	180	240
265.20	10	200	310
265.22	10	220	370

Wide chisel with guard



- Chisel with guard, diameter: 85 mm.
- Chrome vanadium forged steel and hardened to 57 HRC on edge.
- Edge resharpening with grinder.
- Head hardened to prevent head effect.
- Blade width: 60 mm. • Length: 250 mm.
- Presentation: lacquered.

Item	L [mm]	ΔΔ [g]
260.P	250	630

Set of chisels and cape chisels on holder



Item	Content set	Dimension [mm]	ΔΔ [kg]
263.265JS5	263.15-20-25 265.18-22	255 x 180 x 30	1.9

262A - Ribbed chisels, round head



- Forged chisels with rounded edges for better handling.
- Cylinder-shaped head for safer impact.
- Cutting edge hardness: 57 to 59 HRC.
- Cutting edge angle: 60°.
- Presentation: zinc-plated finish.

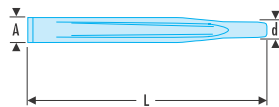

Item	A [mm]	d [mm]	L [mm]	ΔΔ [g]
262A.15	21	16	150	170
262A.18	24	18	180	250
262A.20	26	18	200	340
262A.25	29	21	260	500

Set of ribbed chisels on holder

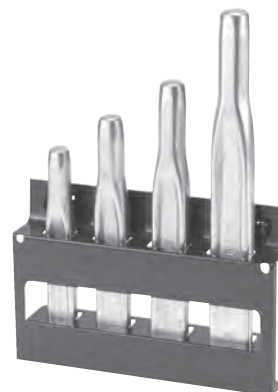

Item	Content set	Dimension [mm]	ΔΔ [kg]
262AJS4	262A.15-18-20-25	180 x 30 x 250	1.5

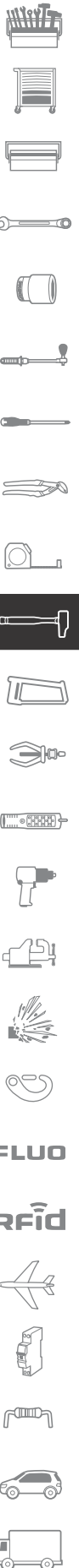

IMPACT TOOLS MODULES

Impact tools module



- Comprising:
 - 205C.50: composite hammer 500 g.
 - 208A.32CBA: steel mallet 32 mm.
 - 248. 4-5-6 mm: long drift punches.
 - 263.18: chisel.
 - 256.6: punch.



	H [mm]	L [mm]	Contents	Qty	$\Delta\Delta$ [kg]
MOD.MI7	40	418	Tray PL.333	7	1.7

Impact tools foam module



- Comprising:
 - 200C.40: composite riveting hammer 40 mm.
 - 208A.32CBA: steel mallet 32 mm.
 - 256.6: punch accuracy 6 mm.
 - 263.G19: sheathed chisel 190 mm.
 - 249.G 4 - 5 - 6 mm: sheathed drift punches.



	H [mm]	L [mm]	Contents	Qty	$\Delta\Delta$ [kg]
MODM.MI6	45	418	Tray PM.MODMI6	7	2.2

Impact tools 205C long drift punches foam module



- Comprising:
 - 205C.50: DIN composite hammer 500 g.
 - 208A.32CBA: steel mallet 32 mm.
 - 256.6: punch accuracy 6 mm.
 - 263.18: chisel.
 - 248. 4 - 5 - 6 mm: long drift punches.



	H [mm]	L [mm]	Contents	Qty	$\Delta\Delta$ [kg]
MODM.MI7	45	418	Tray PM.MODMI7	7	1.7

Impact tools 205C long sheathed drift punches foam module



- Comprising:
 - 205C.50: DIN composite hammer 500 g.
 - 208A.32CB: steel mallet 32 mm.
 - 263.G19: sheathed chisel 190 mm.
 - 256.6: punch accuracy 6 mm.
 - 249.G 4 - 5 - 6 mm: 3 long-reach sheathed drift punches.



	H [mm]	L [mm]	Contents	Qty	$\Delta\Delta$ [kg]
MODM.MI5	45	418	Tray PM.MODMI5	7	1.8

Impact tools 200 H module



- Comprising:
 - 200H.32: hickory riveting hammer 32 mm.
 - 208A.32CBA: steel mallet 32 mm.
 - 263.20: chisel.
 - 256.6: punch.
 - 248. 4 - 5 - 6 mm: long drift punches.

	H [mm]	L [mm]	Contents	Qty	ΔΔ [kg]
MOD.MI1	40	418	Tray PL.333	7	1.8

Impact tools 200H foam module



- Comprising:
 - 200H.40: hickory riveting hammer 40 mm.
 - 208A.32CBA: Steel mallet 32mm.
 - 263.20: chisel.
 - 256.6: punch accuracy 6 mm.
 - 248. 4 - 5 - 6 mm: 3 long drift punches.

	H [mm]	L [mm]	Contents	Qty	ΔΔ [kg]
MODM.MI1	45	418	Tray PM.MODMI1	7	1.8

Impact tools 205H module



- Comprising:
 - 205H.50: DIN 500 g hickory hammer.
 - 208A.32CBA: steel mallet 32 mm.
 - 263.18: chisel.
 - 256.6: punch.
 - 248. 4 - 5 - 6 mm: 3 long drift punches.

	H [mm]	L [mm]	Contents	Qty	ΔΔ [kg]
MOD.MI3	40	418	Tray PL.333	7	1.7

Impact tools 205H foam module



- Comprising:
 - 205H.100: DIN 1 kg hickory hammer.
 - 208A.32CBA: steel mallet 32mm.
 - 263.20: chisel.
 - 256.6: punch accuracy 6 mm.
 - 248. 4 - 5 - 6 mm: 3 long drift punches.

	H [mm]	L [mm]	Contents	Qty	ΔΔ [kg]
MODM.MI3	45	418	Tray PM.MODMI3	7	1.8

Impact tools 202H module



- Comprising:
 - 202H.1/2: hickory American hammer.
 - 208A.32CBA: steel mallet 32 mm.
 - 263.18: chisel.
 - 256.6: punch.
 - 248. 4 - 5 - 6 mm: 3 long drift punches.

	H [mm]	L [mm]	Contents	Qty	ΔΔ [kg]
MOD.MI4	40	418	Tray PL.333	7	1.5

Impact tools 202H foam module



- Comprising:
 - 202H.1: 1LB/454g: hickory American hammer.
 - 208A.32CB: steel mallet 32 mm.
 - 263.20: chisel.
 - 256.6: punch accuracy 6 mm.
 - 248. 4 - 5 - 6 mm: 3 long drift punches.

	H [mm]	L [mm]	Contents	Qty	ΔΔ [kg]
MODM.MI4	45	418	Tray PM.MODMI4	7	1.8





SAWING - DRILLING - CUTTING



SAWING

584

Hacksaw frame 584
Hacksaw blades 587



FILES

588

File sets 589
Engineers files 591
Wood rasps 597
Precision files 597



WORKSHOP DRILL BITS, TAPS AND DIES

598

Taps 598
Dies 599
Threading and tapping tool sets 600
Tools for taps and dies 601
Workshop drill bits 602



HOLESAWS

605

Variable pitch holesaws 605

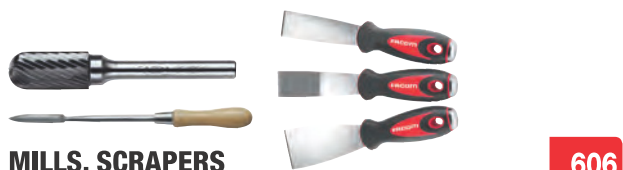

MILLS, SCRAPERS

606

Mills 606
Scrapers 606



METAL SHEARS

608

Metal shears 608



BOLT CROPPERS

610

Bolt croppers 610



CABLE CUTTERS

612

Copper and aluminium cable cutters 612
Steel cable cutters 613



UTILITY KNIVES

615

Utility knives 615



SCISSORS - KNIVES

619

Scissors - knives 619
Knives 620

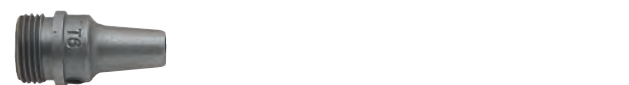

PUNCH KIT

623

Punch kit 623



FLUO

Rfid



HACKSAW FRAME

HIGH PERFORMANCE HACKSAW FRAME 603F

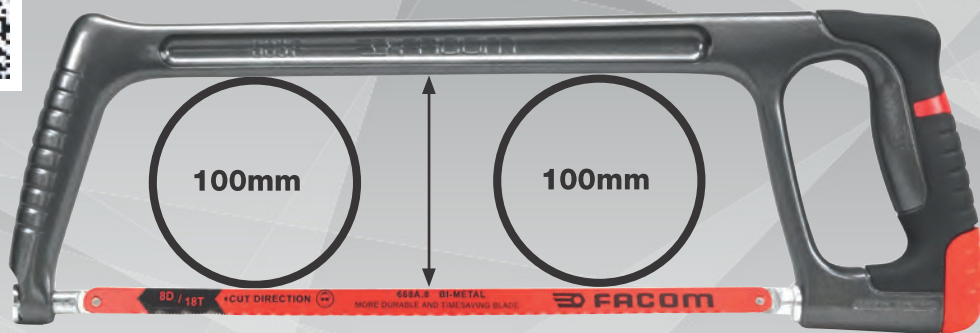
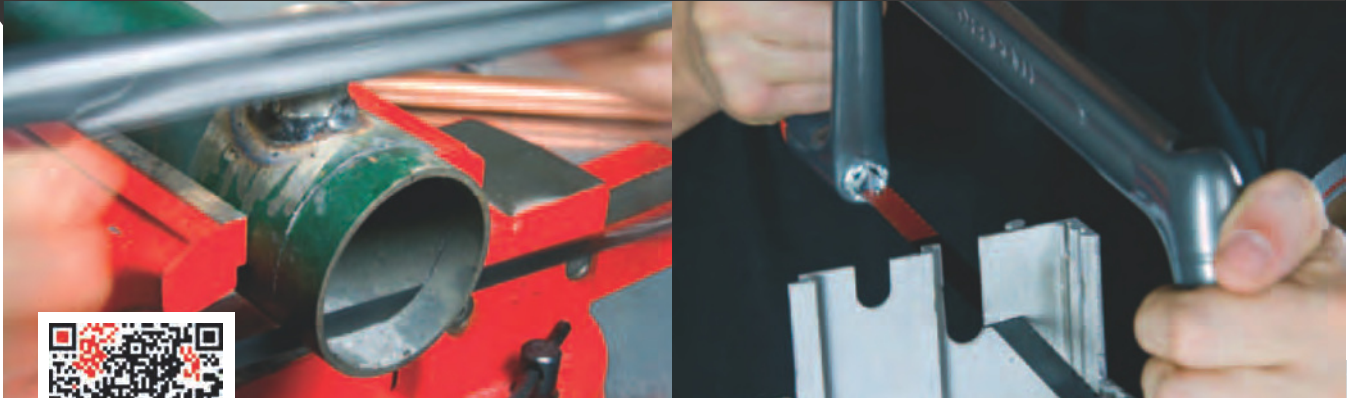

OPTIMUM AND DURABLE CUT

- Constant blade tension: 110 kg controlled automatically.
- Rigid aluminium bow.
- Bi-material ergonomic handle to reduce vibrations.

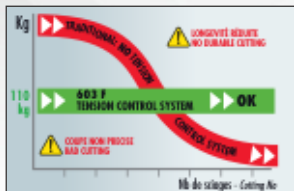

SAVE TIME

- Cutting capacity 100 mm over the full bow length.
- Ultra-fast blade changing.
- 8 cutting positions (every 45°).

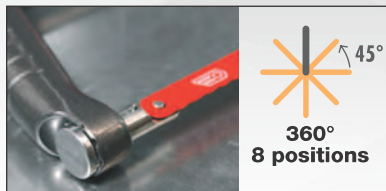

EXACT CUTTING

- For a perfect tension control (110 kg), turn the button till **CLICK**.



■ "High performance" hacksaw frame



NF E 73-073, DIN 6473

- Optimum and durable automatic blade tension control at 110 kg.
- Aluminium bow for maximum stiffness.
- Ergonomic handle for maximum cutting comfort.
- 8 blade positions.
- Ultra-fast blade changing.
- Takes 300 mm blade.
- Dimensions (L. x W.): 440 x 145 mm.
- Supplied with one blade.
- Spare blades: 668A.



	L [mm]	ΔΔ [g]
603F	440	830

HACKSAW FRAME

"TRAVELLING" HACKSAW FRAME 601

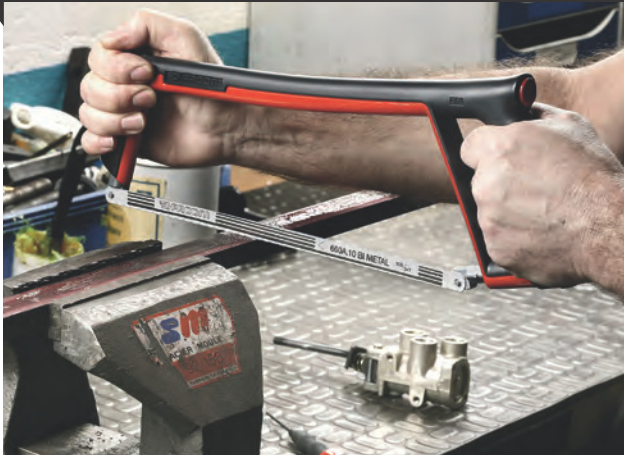

Practical and compact

Compact: stored in a 5-compartment box and in roller-cabinet modules.

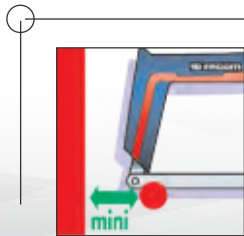

- Minimum clearance to start cutting.

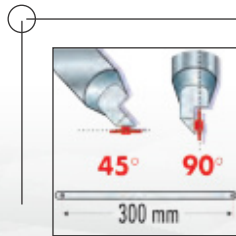

- 2 blade positions on machined and shouldered pins.

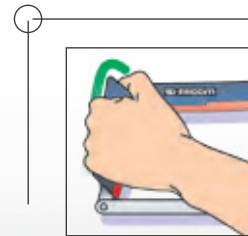

- Left-hand rest.

Compact hacksaw frame

NF E 73-073, DIN 6473

- Impact-resistant steel/resin construction compact and lightweight.
- Blade tension 80 kg.
- 2 blade positions: 45° and 90°.
- Takes 300 mm blade.
- Dimensions (L x W): 385 x 145 mm.
- Supplied with one blade.
- Spare blades: 668A.



Icon	L [mm]	ΔΔ [g]
601	385	590

Flat bow frame - adjuster fitting

NF E 73-073, DIN 6473

- Wood handle.
- Takes 300 mm blade.
- Spare blades: 668A.

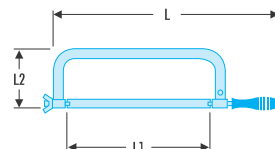

Icon	L [mm]	L1 [mm]	L2 [mm]	ΔΔ [g]
599	520	300	130	600



HACKSAW FRAME

■ Straight frame with blade backing



- Blade can be set to protrude beyond the backing to allow insertion into narrow gaps.
- Takes 300 mm blade.
- Spare blades: 668A.

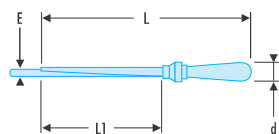

🔪	d [mm]	E [mm]	L [mm]	L1 [mm]	ΔΔ [g]
606A	33	16	350	190	410

■ Revolver frame with sliding blade-guide



- Sliding guide steadies blade throughout cutting stroke.
- A thumbscrew can lock the guide to keep blade end clear.
- Takes 300 mm blade.
- Spare blades: 668A.

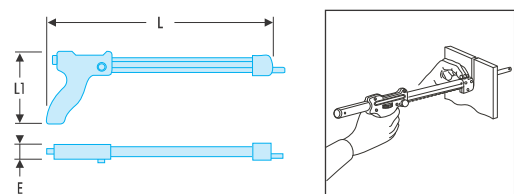

🔪	E [mm]	L [mm]	L1 [mm]	ΔΔ [g]
605.B	30	370	130	780

■ Foam tray saw, tape measure and files



- Comprising:
 - 234.S: Scriber.
 - 603F: Alu hacksaw.
 - 893B.319: Tape measure.
 - CAR.MD200EMA: Flat second-cut file 200 mm with grip.
 - DRD.MD250EMA: Half-round second-cut file 200 mm with grip.
 - PAM.B250EMA: Flat bastard file 200 mm with grip.
 - TRI.MD200EMA: Triangle-shaped second-cut file 200 mm with grip.
 - Foam tray PM.MOD603F.



🔪	H [mm]	Width I [mm]	L [mm]	ΔΔ [kg]
MODM.603F	45	325	418	2.3

FILE SELECTION GUIDE



FACOM technical specifications

- Made from high carbon-content steels.
- Optimum heat treatment for each application.
 - 64 to 66 HRc for engineers files.
 - 53 to 56 HRc for rasps.
 - 65 to 67 HRc for sharpening files.

File selection guide

Four criteria apply :

1. Shape or cross-section.
2. Pattern according to material.
3. Grade according to operation.
 - Standard files: - B: Bastard cut for rough filing.
 - MD: Second cut for general purpose.
- Precision files: - TOA: Bastard cut for rough filing.
- T2A: for normal smooth filing.

Pattern selection according to material		Steel	Cast Iron	Brass	Hard plastics, wood etc.	Aluminium and soft materials
Double cut for steel and metals.		●	●	●	●	
Single cut for good surface finish, sharpening saws, lathe filling and fitters' requirements.		●				
Dreadnaught, for soft materials, sheet metal, etc. Leaves a smooth finish.		●		●	●	●
Rasp for soft materials and wood. Produces a rough surface.					●	●

FLAT PAM		
HALF-ROUND 	DRD ROUND RD 	THREE-
SQUARE TRI 		SQUARE CAR

4. File length.
• Lengths quoted are always without tang.
Main shapes

SELECTION GUIDE: WOOD HANDLES FOR FILES AND RASPS



Files	100 mm	125 mm	150 mm	200 mm	250 mm	300 mm
PAM: Flat hand	MAN.3	-	MAN.3	MAN.2	MAN.1	MAN.0
DRD: Half-round	MAN.3	-	MAN.3	MAN.2	MAN.1	MAN.0
TRI: Three-square	MAN.4	MAN.3	MAN.3	MAN.2	MAN.1	MAN.1
RD: Round	MAN.4	MAN.4	MAN.4	MAN.3	MAN.2	MAN.0
CAR: Square	MAN.4	MAN.4	MAN.4	MAN.3	MAN.2	MAN.1
CT: Knife	MAN.3	MAN.3	MAN.2	MAN.2	MAN.1	MAN.1
PIL: Pillar	MAN.3	-	MAN.2	MAN.2	MAN.1	-
PDE: Fat warding	MAN.3	MAN.3	MAN.2	MAN.2	MAN.1	MAN.1
BAR: Barette	MAN.3	-	MAN.2	MAN.2	MAN.1	-
FRC / FRO: Tapered	-	-	-	-	-	MAN.0
TRO: Round for chainsaws	-	-	MAN.4	MAN.4	-	-
Type of rasps	100 mm	125 mm	150 mm	200 mm	250 mm	300 mm
RAB.DRD: Half-round	-	-	-	-	MAN.1	MAN.0
RAB.P: Flat	-	-	-	-	MAN.1	MAN.0
RAB.RD: Round	-	-	-	-	MAN.1	MAN.0

FILE SETS

MAN - Wood handles for files and rasps

- Varnished wood handles with nickel-plated steel ferrule.
- Supplied singly.



File	d [mm]	L [mm]	ΔΔ [g]
MAN.0	34	132	55
MAN.1	32	124	45
MAN.2	28	110	40
MAN.3	25	102	30
MAN.4	22	98	25

SELECTION GUIDE: PLASTIC HANDLES FOR FILES AND RASPS



Files	100 mm	125 mm	150 mm	200 mm	250 mm	300 mm
PAM: Flat hand	MP.4	-	MP.3	MP.2	MP.1	MP.0
DRD: Half-round	MP.4	-	MP.3	MP.2	MP.1	MP.0
TRI: Three-square	-	-	MP.3	MP.1	MP.0	MP.0
RD: Round	MP.4	MP.4	MP.4	MP.3	MP.1	MP.0
CAR: Square	-	-	MP.4	MP.3	MP.1	MP.0
CT: Knife	MP.4	-	MP.3	MP.2	MP.1	-
PIL: Pillar	MP.4	-	MP.3	MP.2	MP.1	-
PDE: Fat warding	MP.4	-	MP.3	MP.2	MP.1	-
BAR: Barette	MP.4	-	MP.3	MP.2	MP.1	-
FRC / FRO: Tapered	-	-	-	-	-	MP.0
TRO: Round for chainsaws	-	-	MP.4	MP.4	-	-
Type of rasps	100 mm	125 mm	150 mm	200 mm	250 mm	300 mm
RAB.DRD: Half-round	-	-	-	-	MP.1	MP.0
RAB.P: Flat	-	-	-	-	MP.1	MP.0
RAB.RD: Round	-	-	-	-	MP.1	-

MP - Plastic handles for files and rasps

- Ergonomic handle in plastic resistant to workshop solvents.
- Supplied singly.



File	d [mm]	L [mm]	ΔΔ [g]
MP.0	30	120	40
MP.1	30	120	45
MP.2	28	120	40
MP.3	28	105	35
MP.4	25	100	20



FLUO

Rfid

FILE SETS

Set of 5 files



- Set of 5 files with varnished wood handles, for general engineering and automotive applications.
- Comprising:
 - PAM.B250A: Flat bastard file.
 - DRD.MD250A: Half-round second-cut file.
 - CAR.MD200EMA: Square second-cut file.
 - TRI.MD200EMA: Triangle second-cut file.
 - RD.MD200A: Round second-cut file.
- Supplied in grey hammer-finish wall-rack CKS.35A.

	$\Delta\Delta$ [kg]
STG	1.265

Set of 9 files



- Set of 9 files and rasps for engineering and industrial maintenance.
- Comprising:
 - PAM.B250A: Flat bastard file.
 - PAM.MD200A: Flat second-cut file.
 - DRD.B250A: Half-round second cut bastard file.
 - DRD.MD200A: Half-round second-cut file.
 - RD.B250A: Round bastard file.
 - RD.MD200A: Round second-cut file.
 - CAR.MD200A: Square second-cut file.
 - TRI.MD150A: Triangle second-cut file.
 - RAB.DRDMD250A: Half-round second-cut rasp.
- Supplied in grey hammer-finish wall-rack CKS.34A.

	$\Delta\Delta$ [kg]
STU	2.150

Set of 6 locksmiths files - length 100 mm



- NFE 75-001, NFE 75-002**
- Geneva pattern with wooden handle.
 - Available in 3 different cuts.
 - CLE.BAM100A: Bastard cut files.
 - CLE.MDAM100A: Second cut files.
 - CLE.DAM100A: Smooth cut files.
 - In plastic wallet dimensions (L. x D. x H.): 200 x 105 x 11 mm.

	H [mm]	L [mm]	$\Delta\Delta$ [g]
CLE.BAM100A	11	200	210
CLE.MDAM100A	11	200	210
CLE.DAM100A	11	200	210

Module of 5 files 200 mm long with handle



- Comprising:
 - PAM.B200EMA: Flat bastard file.
 - DRD.MD200EMA: Half-round second-cut file.
 - CAR.MD200EMA: Square second-cut file.
 - TRI.MD200EMA: Triangle second-cut file.
 - RD.MD200EMA: Round second-cut file.
- Finish: ergonomic handle in plastic resistant to workshop solvents.

	H [mm]	L [mm]	$\Delta\Delta$ [g]
MOD.LIM	40	418	950

FILE SETS

Set of 5 second-cut files 200 mm long



NFE 75-001, NFE 75-002

- Comprising:
 - PAM.MD200EMA: Flat second-cut file.
 - DRD.MD200EMA: Half-round second-cut file.
 - CAR.MD200EMA: Square second-cut file.
 - RD.MD200EMA: Round second-cut file.
 - TRI.MD200EMA: Triangle second-cut file.
- Finish: ergonomic handle in plastic resistant to workshop solvents.

Icon	ΔΔ [g]
LIM200EM.J5	820

Set of 5 second-cut files 250 mm long



NFE 75-001, NFE 75-002

- Comprising:
 - PAM.MD250EMA: Flat second-cut file.
 - DRD.MD250EMA: Half-round second-cut file.
 - CAR.MD250EMA: Square second-cut file.
 - RD.MD250EMA: Round second-cut file.
 - TRI.MD250EMA: Triangle second-cut file.
- Finish: ergonomic handle in plastic resistant to workshop solvents.

Icon	ΔΔ [g]
LIM250EM.J5	1350

PAM.MDA - Half-round flat files



NFE 75-001, NFE 75-002

- Flat files with handle.
- 2 double cut squares.
- 1 single cut square.
- 1 smooth cut.
- Designed for steel, cast iron, brass, and hard plastics.

Icon	E x E1 [mm]	L [mm]	ΔΔ [g]
PAM.MD150A	4 x 15	150	75
PAM.MD200A	5 x 20	200	145
PAM.MD250A	6 x 25	250	270

PAM.MDEMA - Flat half-cut files with handle



NFE 75-001, NFE 75-002

- Flat files with handle.
- 2 double cut squares.
- 1 single cut square.
- 1 smooth cut.
- Finish: ergonomic handle in plastic resistant to workshop solvents.
- Designed for steel, cast iron, brass, and hard plastics.

Icon	E x E1 [mm]	L [mm]	ΔΔ [g]
PAM.MD150EMA	4 x 15	150	140
PAM.MD200EMA	5 x 20	200	200
PAM.MD250EMA	6 x 25	250	340

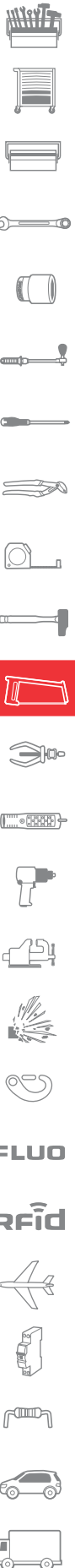

ENGINEERS FILES

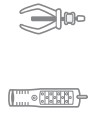

FLUO

Rfid



ENGINEERS FILES

PAM.BA - Flat bastard files



NFE 75-001, NFE 75-002

- Flat files with handle.
- 2 double cut squares.
- 1 single cut square.
- 1 smooth cut.
- Designed for roughing steel, cast iron, brass, and hard plastics.

🔗	E x E1 [mm]	L [mm]	ΔΔ [g]
PAM.B150A	4 x 15	150	60
PAM.B200A	5 x 20	200	145
PAM.B250A	6 x 25	250	270

PAM.BEMA - Flat bastard files with handle



NFE 75-001, NFE 75-002

- Flat files with handle.
- 2 double cut squares.
- 1 single cut square.
- 1 smooth cut.
- Finish: ergonomic handle in plastic resistant to workshop solvents.
- Designed for roughing steel, cast iron, brass, and hard plastics.

🔗	E x E1 [mm]	L [mm]	ΔΔ [g]
PAM.B150EMA	4 x 15	150	140
PAM.B200EMA	5 x 20	200	200
PAM.B250EMA	6 x 25	250	340

DRD.MDA - Half-round second-cut files

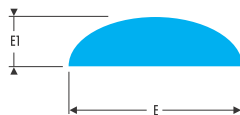

NFE 75-001, NFE 75-002

- Second-cut files with handle.
- Double second-cut squares.
- Double cut square.
- Designed for steel, cast iron, brass, and hard plastics.

🔗	E x E1 [mm]	L [mm]	ΔΔ [g]
DRD.MD150A	4,5 x 16,0	150	60
DRD.MD200A	6 x 21	200	115
DRD.MD250A	7 x 25	250	220

DRD.MDEMA - Half-round second-cut files with handle

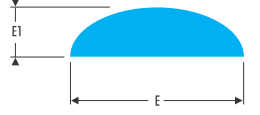

NFE 75-001, NFE 75-002

- Second-cut files with handle.
- Double second-cut squares.
- Double cut square.
- Finish: ergonomic handle in plastic resistant to workshop solvents.
- Designed for steel, cast iron, brass, and hard plastics.

🔗	E x E1 [mm]	L [mm]	ΔΔ [g]
DRD.MD150EMA	4,5 x 16,0	150	100
DRD.MD200EMA	6 x 21	200	160
DRD.MD250EMA	7 x 25	250	280

ENGINEERS FILES

DRD.BA - Half-round bastard files

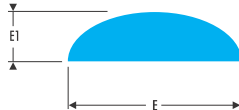

NFE 75-001, NFE 75-002

- Second-cut files with handle.
- Double second-cut squares.
- Double cut square.
- Designed for roughing steel, cast iron, brass, and hard plastics.

🔪	E x E1 [mm]	L [mm]	ΔΔ [g]
DRD.B150A	4,5 x 16,0	150	60
DRD.B200A	6 x 21	200	115
DRD.B250A	7 x 25	250	220

RD.MDA - Second-cut round files

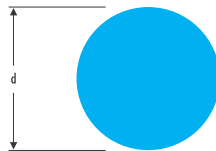

NFE 75-001, NFE 75-002

- Round files with handle.
- Double square.
- Designed for steel, cast iron, brass, and hard plastics.

🔪	d [mm]	L [mm]	ΔΔ [g]
RD.MD150A	6	150	50
RD.MD200A	8	200	75
RD.MD250A	10	250	135

DRD.BEMA - Half-round bastard files with handle

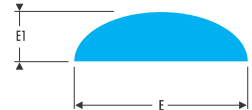

NFE 75-001, NFE 75-002

- Second-cut files with handle.
- Double second-cut squares.
- Double cut square.
- Ergonomic handle in plastic resistant to workshop solvents.
- Designed for roughing steel, cast iron, brass, and hard plastics.

🔪	E x E1 [mm]	L [mm]	ΔΔ [g]
DRD.B150EMA	4,5 x 16,0	150	100
DRD.B200EMA	6 x 21	200	160
DRD.B250EMA	7 x 25	250	280

RD.MDEMA - Second-cut round files with handle

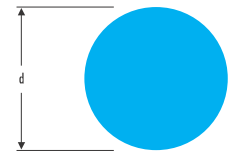

NFE 75-001, NFE 75-002

- Round files with handle.
- Double square.
- Finish: ergonomic handle in plastic resistant to workshop solvents.
- Designed for steel, cast iron, brass, and hard plastics.

🔪	d [mm]	L [mm]	ΔΔ [g]
RD.MD150EMA	6	150	100
RD.MD200EMA	8	200	140
RD.MD250EMA	10	250	208



ENGINEERS FILES

RD.BA - Round bastard files

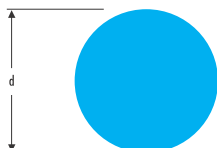

NFE 75-001, NFE 75-002

- Round files with handle.
- Double square.
- Designed for roughing steel, cast iron, brass, and hard plastics.

	d [mm]	L [mm]	$\Delta\Delta$ [g]
RD.B150A	6	150	50
RD.B200A	8	200	75
RD.B250A	10	250	135

RD.BEMA - Round bastard files with handle

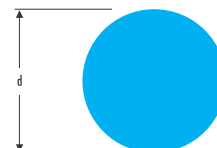

NFE 75-001, NFE 75-002

- Round files with handle.
- Double square.
- Finish: ergonomic handle in plastic resistant to workshop solvents.
- Designed for roughing steel, cast iron, brass, and hard plastics.

	d [mm]	L [mm]	$\Delta\Delta$ [g]
RD.B150EMA	6	150	100
RD.B200EMA	8	200	140
RD.B250EMA	10	250	200

CAR.MDA - Second-cut square files

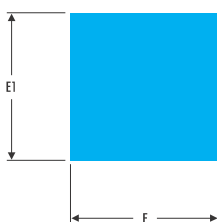

NFE 75-001, NFE 75-002

- Square files with handle.
- Double square on 4 cuts.
- Designed for steel, cast iron, brass, and hard plastics.

	E x E1 [mm]	L [mm]	$\Delta\Delta$ [g]
CAR.MD150A	6 x 6	150	60
CAR.MD200A	8 x 8	200	80
CAR.MD250A	10 x 10	250	140

CAR.MDEMA - Second-cut square files with handle

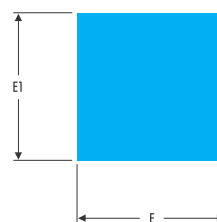

NFE 75-001, NFE 75-002

- Square files with handle.
- Double square on 4 cuts.
- Finish: ergonomic handle in plastic resistant to workshop solvents.
- Designed for steel, cast iron, brass, and hard plastics.

	E x E1 [mm]	L [mm]	$\Delta\Delta$ [g]
CAR.MD150EMA	6 x 6	150	100
CAR.MD200EMA	8 x 8	200	120
CAR.MD250EMA	10 x 10	250	190

ENGINEERS FILES

CAR.BEMA - Square bastard files with handle

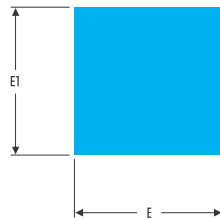

NFE 75-001, NFE 75-002

- Square files with handle.
- Double square on 4 cuts.
- Finish: ergonomic handle in plastic resistant to workshop solvents.
- Designed for roughing steel, cast iron, brass, and hard plastics.

🔪	E x E1 [mm]	L [mm]	ΔΔ [g]
CAR.B150EMA	6 x 6	150	100
CAR.B200EMA	8 x 8	200	120
CAR.B250EMA	10 x 10	250	190

TRI.MDEMA - Second-cut triangle files with handle

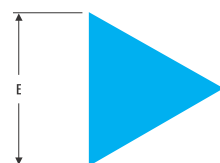

NFE 75-001, NFE 75-002

- Triangle files with handle.
- Double square on 3 cuts.
- Finish: ergonomic handle in plastic resistant to workshop solvents.
- Designed for steel, cast iron, brass, and hard plastics.

🔪	E [mm]	L [mm]	ΔΔ [g]
TRI.MD150EMA	11	150	130
TRI.MD200EMA	15	200	210
TRI.MD250EMA	19	250	330

TRI.MDA - Second-cut triangle files

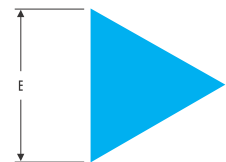

NFE 75-001, NFE 75-002

- Triangle files with handle.
- Double square on 3 cuts.
- Designed for steel, cast iron, brass, and hard plastics.

🔪	E [mm]	L [mm]	ΔΔ [g]
TRI.MD150A	11	150	90
TRI.MD200A	15	200	170
TRI.MD250A	19	250	270

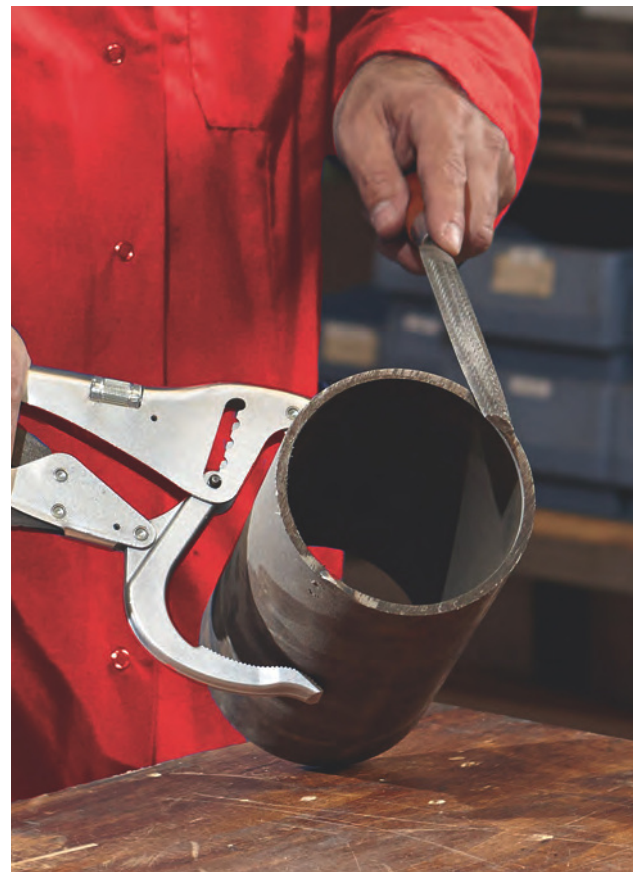

FLUO

RFid



ENGINEERS FILES

■ TRI.BEMA - Triangle bastard files with handle

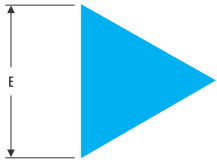

NFE 75-001, NFE 75-002

- Triangle files with handle.
- Double square on 3 cuts.
- Ergonomic handle in plastic resistant to workshop solvents.
- Designed for roughing steel, cast iron, brass, and hard plastics.



🔗	E [mm]	L [mm]	ΔΔ [g]
TR1.B150EMA	11	150	130
TR1.B200EMA	15	200	210
TR1.B250EMA	19	250	330

WOOD RASPS

■ RAB.DRDMDA - Half-round second-cut rasps medium cut

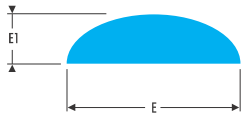

NFE 75-001, NFE 75-002

- Second-cut rasps with handle.
- RAB.DRDB250EMA - RAB.DRDMD300EMA: Rasp with handle.
- Finish: ergonomic handle in plastic resistant to workshop solvents.
- Designed for soft materials, aluminium, lead, plastic or wood.



🔗	E x E1 [mm]	L [mm]	ΔΔ [g]
RAB.DRDMD250A	25 x 7	250	260
RAB.DRDMD300A	30,0 x 8,5	300	420
RAB.DRDMD250EMA	25 x 7	250	300
RAB.DRDMD300EMA	30,0 x 8,5	300	380

■ RAB.DRDBA - Half-round bastard rasps large cut

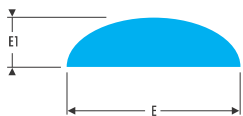

NFE 75-001, NFE 75-002

- Second-cut rasps with handle.
- RAB.DRDB300EMA: Rasp with handle.
- Finish: ergonomic handle in plastic resistant to workshop solvents.
- Designed for roughing work, soft materials, aluminium, lead, plastic or wood.



🔗	E x E1 [mm]	L [mm]	ΔΔ [g]
RAB.DRDB250A	25 x 7	250	260
RAB.DRDB300EMA	30,0 x 8,5	300	480

WOOD RASPS

■ RAB.RDA - Round second-cut rasps medium cut

NFE 75-001, NFE 75-002

- Round rasps with handle.
- RAB.RD250EMA: Rasp with handle.
- Finish: ergonomic handle in plastic resistant to workshop solvents.
- Designed for soft materials, aluminium, lead, plastic or wood.



🔗	d [mm]	L [mm]	ΔΔ [g]
RAB.RD250A	10	250	140
RAB.RD250EMA	10	250	180

■ RAB.P - Flat rasps medium cut

- Flat rasps with handle.
- Bastard finish: recommended for roughing work.
- Second cut finish recommended for current work.
- Designed for current work, for soft materials, aluminium, lead, plastic or wood.



🔗	E x E1 [mm]	L [mm]	ΔΔ [g]
RAB.PB250A	25 x 6	250	320
RAB.PMD250A	25 x 6	250	320



PRECISION FILES

■ AS - Selections of 6 and 12 needle files

- AS.6L: Selection of 6 needle files: round (RD), half-round (DRD), flat entry (DPE), square (CAR), triangular (TRI), tile (PAM).
- AS.12L: Selection of 12 needle files: round (RD), half-round (DRD), flat entry (PDE), crossing file (FS), knife (CT), square (CAR), triangular (TRI), file (PAM), strip (BAR), BR tile (PAMBR), hook (CRO), oval (OV).
- T0 for rough filing.
- T2 for precise filing.

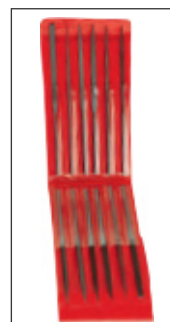
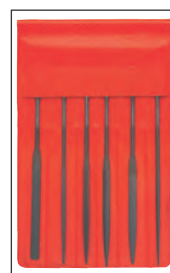

🔗	L [mm]	Content set	Contents	Files	ΔΔ [g]
AS.6L140T0A	140	6	Plastic wallet	T0	115
AS.6L140T2A	140	6	Plastic wallet	T2	115
AS.6L160T0A	160	6	Plastic wallet	T0	140
AS.6L160T2A	160	6	Plastic wallet	T2	140
AS.12LBC100T0A	100	12	Cardboard box	T0	55
AS.12LBC100T2A	100	12	Cardboard box	T2	55
AS.12LBP140T0A	140	12	Plastic box	T0	115
AS.12LBP140T2A	140	12	Plastic box	T2	115
AS.12LBP160T0A	160	12	Plastic box	T0	140
AS.12LBP160T2A	160	12	Plastic box	T2	140
AS.12LTP180T0A	180	12	Plastic wallet	T0	175
AS.12LTP180T2A	180	12	Plastic wallet	T2	175

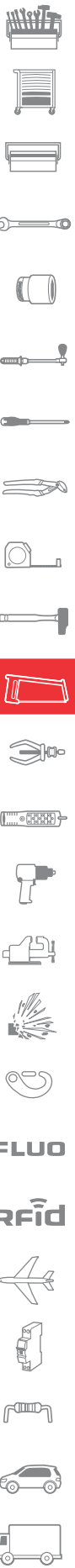

TAPS

TAP SELECTION GUIDE



- Ground-thread backed-off taps.
- ISO metric RH thread.6H machining.
- Set of 2 (ref. T2) for soft metals:
1 taper tap, 1 bottoming tap.
- Set of 3 (ref. T3) for hard metals:
1 taper tap, 1 second tap, 1 bottoming tap.

- Max. hardness: 70 daN/mm²:
- for taps 227 and 80 daN/mm²
- for taps 227.S.

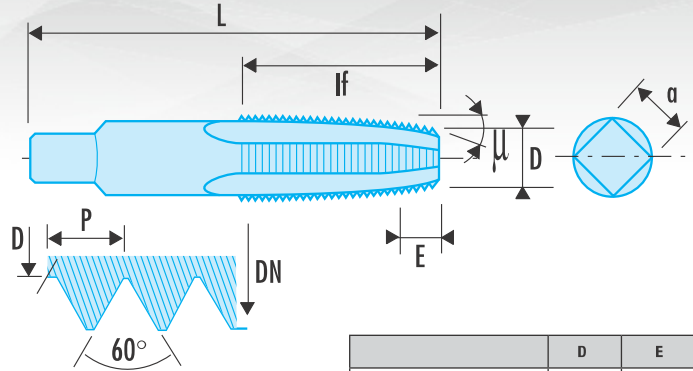

	D	E
Second	= 6 P	6°
Bottoming DN - 1.2p.	= 3.5 P	9°
Bottoming 18°	= 2 P	18°

227 - Standard taps



NF ISO 529, NFEN 22857, ISO 529, ISO 2857

- HSS steel.
- 227.T3: Set of 3 taps (taper, second and bottoming).
- 227.T2: Set of 2 taps (taper and bottoming).

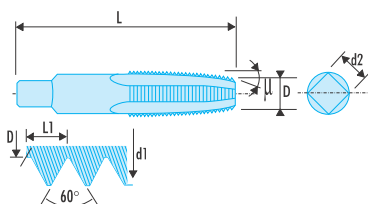

Ref	d1 [mm]	d2 [mm]	L [mm]	L1 [mm]	Content set	ΔΔ [g]
227.3X50T3	3	2,50	48	0,50	x 3	20
227.4X70T3	4	3,15	53	0,70	x 3	25
227.5X80T3	5	4,00	58	0,80	x 3	40
227.6X100T3	6	5,00	66	1,00	x 3	50
227.7X100T3	7	5,60	66	1,00	x 3	60
227.8X125T3	8	6,30	72	1,25	x 3	85
227.9X125T3	9	7,10	72	1,25	x 3	100
227.10X150T3	10	8,00	80	1,50	x 3	140
227.12X175T3	12	7,10	89	1,75	x 3	150
227.14X200T3	14	9,00	95	2,00	x 3	240
227.16X200T3	16	10,00	102	2,00	x 3	305
227.18X250T3	18	11,20	112	2,50	x 3	460
227.20X250T3	20	11,20	112	2,50	x 3	490
227.3X50T2	3	2,50	48	0,50	x 2	10
227.4X70T2	4	3,15	53	0,70	x 2	10
227.5X80T2	5	4,00	58	0,80	x 2	15
227.6X100T2	6	5,00	66	1,00	x 2	25
227.7X100T2	7	5,60	66	1,00	x 2	45
227.8X125T2	8	6,30	72	1,25	x 2	60
227.10X150T2	10	8,00	80	1,50	x 2	70
227.12X175T2	12	7,10	89	1,75	x 2	80

TAPS

227.S - "High performance" cobalt taps

NF ISO 529, NFEN 22857, ISO 529, ISO 2857

- Molybdenum and cobalt steel.
- The hardness of cobalt increases torque resistance and wear compared with standard taps.
- 227.ST3: Set of 3 taps (taper, second and bottoming).
- 227.ST2: Set of 2 taps (taper and bottoming).



Item	d1 [mm]	d2 [mm]	L [mm]	L1 [mm]	Content set	ΔΔ [g]
227.S3X50T3	3	2,50	48	0,50	x 3	15
227.S4X70T3	4	3,15	53	0,70	x 3	25
227.S5X80T3	5	4,00	58	0,80	x 3	40
227.S6X100T3	6	5,00	66	1,00	x 3	50
227.S8X125T3	8	6,30	72	1,25	x 3	85
227.S10X150T3	10	7,10	80	1,50	x 3	140
227.S12X175T3	12	8,00	89	1,75	x 3	150
227.S3X50T2	3	2,50	48	0,50	x 2	5
227.S4X70T2	4	3,15	53	0,70	x 2	10
227.S5X80T2	5	4,00	58	0,80	x 2	15
227.S6X100T2	6	5,00	66	1,00	x 2	25
227.S7X100T2	7	5,60	66	1,00	x 2	45
227.S8X125T2	8	6,30	72	1,25	x 2	50
227.S9X125T2	9	7,10	72	1,25	x 2	50
227.S10X150T2	10	8,00	80	1,50	x 2	70
227.S12X175T2	12	7,10	89	1,75	x 2	80
227.S14X200T2	14	9,00	95	2,00	x 2	160
227.S16X200T2	16	10,00	102	2,00	x 2	200
227.S18X250T2	18	11,20	112	2,50	x 2	290



DIES

221 - Split dies

NF ISO 261, ISO 261, DIN ISO 261

- ISO metric RH thread.
- Chrome-vanadium HSS hardened to 62/64 HRC (234 daN/mm²).
- Tapered adjusting screw.



Item	d [mm]	d1 [mm]	d2 [mm]	E [mm]	E1 [mm]	ΔΔ [g]
221.3X50	25,4	3	0,50	8	3,5	25
221.4X70	25,4	4	0,70	8	3,5	25
221.5X80	25,4	5	0,80	8	3,5	30
221.6X100	25,4	6	1,00	9	3,5	30
221.7X100	25,4	7	1,00	9	3,5	30
221.8X125	25,4	8	1,25	9	3,5	30
221.9X125	25,4	9	1,25	9	3,5	30
221.10X150	38,1	10	1,50	13	6,0	80
221.12X175	38,1	12	1,75	13	6,0	90
221.14X200	38,1	14	2,00	13	6,0	80
221.16X200	38,1	16	2,00	13	6,0	75
221.18X250	38,1	18	2,50	15	8,0	75



THREADING AND TAPPING TOOL SETS

221 - Tap and die sets



NFE 75-001, NFE 75-002

- Each selection includes sets of two taps per dimension: taper and bottoming.
- Selections Ref 227.SJ1 and 227.SJ2 include cobalt taps (Ref 227.S).
- Tray PL.47 and box BT.109G: for selection Ref 224.227J1 and 221.227SJ1.
- Tray PL.46 and box BT.105: for selection Ref 224.227J2 and 221.227SJ2.

Ref	d [mm]	H [mm]	L [mm]	P [mm]	ΔΔ [kg]
221.227J1	M3 - M4 - M5 - M6 - M7 - M8 - M9 - M10 - M12	53	470	195	3.1
221.227SJ1	M3 - M4 - M5 - M6 - M7 - M8 - M9 - M10 - M12	53	470	195	3.1
221.227J2	M3 - M4 - M5 - M6 - M7 - M8 - M9 - M10 - M12 - M14 - M16 - M18	58	540	284	5.7
221.227SJ2	M3 - M4 - M5 - M6 - M7 - M8 - M9 - M10 - M12 - M14 - M16 - M18	58	540	284	5.7

227.A - Tap and drill-bit sets



NFE 75-001, NFE 75-002

- Each selection includes sets of 3 taps per dimension: taper, second and bottoming.
- Selection Ref 227.SJ2A includes cobalt taps (Ref 227.S).
- Supplied in metal box BT.228J2.

Ref	d [mm]	H [mm]	L [mm]	P [mm]	Drill Bits	ΔΔ [kg]
227.J2A	M3 - M4 - M5 - M6 - M8 - M10 - M12	57	105	172	2,5 - 3,3 - 4,2 - 5,0 - 6,8 - 8,5 - 10,2 mm	1.1
227.SJ2A	M3 - M4 - M5 - M6 - M8 - M10 - M12	57	105	172	2,5 - 3,3 - 4,2 - 5,0 - 6,8 - 8,5 - 10,2 mm	1.1

227 - Tap set



NFE 75-001, NFE 75-002

- Each selection includes sets of 3 taps per dimension: taper, second and bottoming.
- Selection Ref 227.SJ1 includes cobalt taps (Ref 227.S).
- Supplied in metal box BT.228J1.

Ref	d [mm]	H [mm]	L [mm]	P [mm]	Qty	ΔΔ [g]
227.J1	M3 - M4 - M5 - M6 - M8 - M10 - M12	31	118	118	21 taps	720
227.SJ1	M3 - M4 - M5 - M6 - M8 - M10 - M12	31	118	118	21 cobalt taps	720

THREAD RESTORING TOOLS

237 - Thread restoring tool

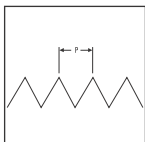

- To restore male and female screw threads.

Ref	L [mm]	P [mm]	Thread	ΔΔ [g]
237.A	230	75 - 100 - 125 - 150 - 175 - 200 - 250 - 300	SI	120
237.B	230	80 - 100 - 125 - 150 - 175 - 200 - 250 - 300	ISO	125
237.C	230	10F - 11F - 12F - 14F - 16F - 18F - 20F - 24F	WHITWORTH	125

TOOLS FOR TAPS AND DIES

830A.L - Long ratcheting tap wrenches

- Ideal for cutting threads in tight recesses.
- Two-way ratchet.
- Ratchet lock.
- Finish: polished chromed.



	d [mm]	L [mm]	Open Position maxi [mm]	For Tapp	ΔΔ [g]
830A.5L	20,5	250	5	M6	230
830A.10L	25,5	300	8	M12	415

830A - Short ratcheting tap wrenches

- Two-way ratchet.
- Ratchet lock.
- Finish: polished chromed.



	d [mm]	L [mm]	Open Position maxi [mm]	Open Position mini [mm]	For Tapp	Tapping	ΔΔ [g]
830A.5	20,5	85	5	5	M6	M6	165
830A.10	25,5	105	8	8	M12	M12	312

830A.RN - Repair kits

- Comprising chuck and spring.
- 830A.5RN, for 830A.5 and 830A.5L.
- 830A.10RN, for 830A.10 and 830A.10L.



	ΔΔ [g]
830A.5RN	15
830A.10RN	15

831 - Adjustable tap wrenches

- NF E 66-130
- Pressure-cast Zamak body. Machined and hardened clamp.
- Finish: grey hammered finish.



	L [mm]	Open Position maxi [mm]	Open Position mini [mm]	Tapping	ΔΔ [g]
831.1	180	2-8	2-8	M3->M7	100
831.2	300	4-11	4-11	M5->M12	300
831.3	385	5-16	5-16	M6->M12	705

832 - Die stocks

- Pressure-cast Zamak body for accurate centring of the die.
- Finish: grey hammered finish.



	d ["]	d [mm]	L [mm]	Organizer for	ΔΔ [g]
832.1'	1	25,4	220	221.3x50 --> 221.9x125	115
832.1'1/2	1'-1/2	38,1	325	221.10x150 --> 221.18x250	410

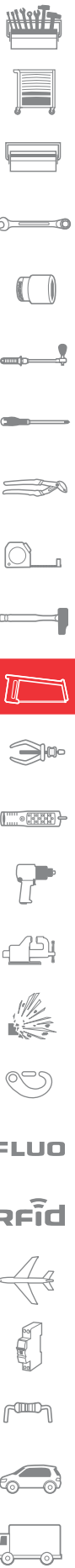

WORKSHOP DRILL BITS

222A.T - Ground twist drills



- For steel up to 800 MPA, stainless steel, grey cast-iron and aluminium alloy.



Ø	d [mm]	L [mm]	ΔΔ [g]
222A.T1	1,0	35	5
222A.T1,5	1,5	40	5
222A.T2	2,0	50	5
222A.T2,5	2,5	57	5
222A.T3	3,0	62	5
222A.T3,3	3,3	65	5
222A.T3,5	3,5	70	5
222A.T4	4,0	75	10
222A.T4,2	4,2	75	10
222A.T4,5	4,5	80	10
222A.T5	5,0	85	10
222A.T5,5	5,5	92	15
222A.T6	6,0	92	15
222A.T6,5	6,5	102	20
222A.T6,8	6,8	105	25

Ø	d [mm]	L [mm]	ΔΔ [g]
222A.T7	7,0	107	25
222A.T7,5	7,5	110	30
222A.T8	8,0	117	35
222A.T8,5	8,5	117	40
222A.T9	9,0	127	50
222A.T9,5	9,5	127	55
222A.T10	10,0	132	60
222A.T10,2	10,2	132	65
222A.T10,5	10,5	132	70
222A.T11	11,0	142	80
222A.T11,5	11,5	142	90
222A.T12	12,0	152	100
222A.T12,5	12,5	152	110
222A.T13	13,0	152	115

222A.TJ - Sets of ground twist drills



NF ISO 235, ISO 235, DIN 338

- For steel up to 800 MPA, stainless steel, grey cast-iron and aluminium alloy.
- Sets 222A.TJ19 and 222A.TJ25: Bits with 5/10 mm increments.
- Sets 222A.TJ50 and 222A.TJ81: Bits with 1/10 mm increments.



Ø	d maxi [mm]	Content set	Dimension [mm]	ΔΔ [g]
222A.TJ19	1 - 10	19	165 x 110 x 35	730
222A.TJ25	1 - 13	25	190 x 110 x 54	1390
222A.TJ50	1 - 5,9	50	135 x 120 x 35	750
222A.TJ81	2 - 10	81	235 x 210 x 145	760

WORKSHOP DRILL BITS

Set of 32 ground twist drills

NF ISO 235, ISO 235, DIN 338

- For steel up to 800 MPA, stainless steel, grey cast-iron and aluminium alloy.
- 20 drill bits Ref 222A.T, diam.: 1 --> 10.5 mm (in 5/10 increments).
- 12 drill bits for riveting and tapping dimension diam.: 1.9 - 2.1 - 2.6 - 2.9 - 3.2 - 3.3 - 3.8 - 4.2 - 5.1 - 6.8 - 7.9 - 10.2 mm.
- Dimensions (L x W x H.): 170 x 110 x 50 mm.



Ref	H [mm]	L [mm]	ΔΔ [kg]
222A.TJ32	50	170	1.2

229A - Boring bits

- For drilling, deburring, boring thin materials: press sheet, non ferrous metals.
- HSS steel.
- Max. thickness recommended: 4 mm.
- Does not require a tapping hole.

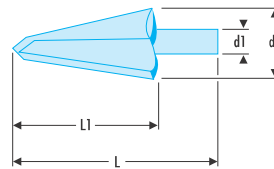

Ref	d1 [mm]	d2 [mm]	L [mm]	L1 [mm]	ΔΔ [g]
229A.1	6	3 - 14	59	37	25
229A.2	8	5 - 20	71	41	45
229A.3	9	16,0 - 30,5	76	48	130

Stepped bits

- For precision-drilling straight bores in all materials.
- No pilot hole required.
- Cross-sharpening: self-centering.
- More aggressive cut for easier drilling and no burrs.
- Better shaving removal.
- Less vibration, quieter operation.
- Parallel shank with 3 flats for positive rotation.
- Laser-engraved diameter marking in a groove.
- 678006: Special ISO gland.
- 678014: PG size step drill.



Ref	d mini - maxi [mm]	d1 [mm]	L [mm]	ΔΔ [g]
229A.ST0	4 - 5 - 6 - 7 - 8 - 9 - 10 - 11 - 12	6	65	25
229A.ST1	4 - 6 - 8 - 10 - 12 - 14 - 16 - 18 - 20	8	75	65
229A.ST2	4 - 6 - 9 - 12 - 15 - 18 - 21 - 24 - 27 - 30 - 33 - 36 - 39	10	107	315
229A.ST3	6 - 9 - 13 - 16 - 19 - 21 - 23 - 26 - 29 - 32 - 35 - 38	10	100	320
678006	6,5 - 8,5 - 10,5 - 12,5 - 16,5 - 20,5 - 25,5 - 29,0 - 32,5 - 36,5 - 40,5	10	96	310
678014	6,0 - 9,0 - 12,5 - 15,2 - 18,6 - 20,4 - 22,5 - 26,0 - 28,3 - 30,5 - 34,0 - 37,0	10	100	300

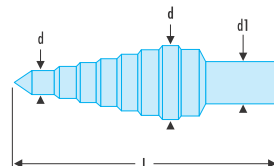

WORKSHOP DRILL BITS

Set of 3 tapered bits



- Capacity: 3 to 30.5 mm.
- Supplied with a bottle of lubricant.
- Supplied in a pressed sheet box, dim. (L. x W. x H.): 120 x 100 x 38 mm.



	H [mm]	L [mm]	$\Delta\Delta$ [g]
229A.J3	38	120	555

BITS FOR IMPACT MACHINERY

Set of 7 short drill bits for straight chucks



- Sharpened carbide tip inserts.
- Ground from stock with L-groove.
- Diameters: 4 - 5 - 6 - 7 - 8 - 10 - 12 mm.
- In a steel case, dim. (L. x W. x H.): 155 x 100 x 30 mm.



	H [mm]	L [mm]	$\Delta\Delta$ [g]
223.SJ7	30	155	355

VARIABLE PITCH HOLESAWS

BIMETAL HSS HOLESAW

For cutting holes through standard materials and metals used in mechanical engineering, sheet-metalworking and plumbing.

- High-speed steel teeth, hardness > 63 HRC.
- Holesaw back in thick sheet steel to minimise vibration.
- Side slots and holes for chip removal.

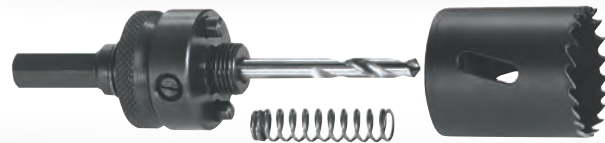

Quick assembly :
chuck, pilot drill, spring, blade.

■ **609A - Variable pitch holesaws**

- Variable pitch holesaws 4 to 6 mm.
- Softer cut and reduced vibration.
- Cutting depth 34 mm.
- Chuck and drill for holesaws 19 to 29 mm 609A.M1.
- Chuck and drill for holesaws 35 to 68 mm 609A.M2.
- Set of 2 spare bits + chuck screws: 609.M-ACC.

609A.29



609A.67



609A	d [mm]	L [mm]	ΔΔ [g]
609A.19	19	51	30
609A.22	22	51	45
609A.29	29	51	80
609A.35	35	51	100
609A.38	38	51	110
609A.40	40	45	140
609A.44	44	45	145

609A	d [mm]	L [mm]	ΔΔ [g]
609A.51	51	45	150
609A.57	57	45	165
609A.64	64	45	185
609A.65	65	45	200
609A.67	67	45	230
609A.68	68	45	285

HOLESAW SETS

■ **609A.J - Set of variable-pitch holesaws with chucks**

- Comprising:
 - 609A.M1: 1 chuck and drill for holesaws 19 to 29 mm.
 - 609A.M2: 1 chuck for holesaws 35 to 64 mm.
 - 609A.M-ACC: Set of 2 spare bits + chuck screws.
- Supplied in a plastic case, dim. (L. x W. x H.): 245 x 185 x 75 mm.



609A	d [mm]	H [mm]	L [mm]	ΔΔ [kg]
609A.J1	22 - 29 - 35 - 44 - 51 - 64	75	245	1.8
609A.J3	19 - 22 - 29 - 35 - 38 - 44 - 51 - 57 - 64	75	245	2.1

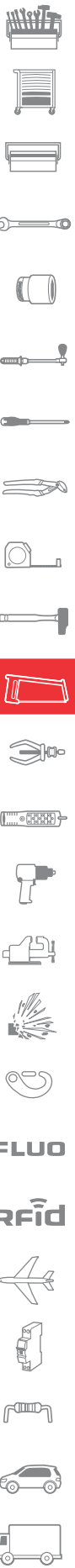

MILLS

VFA - Cutters

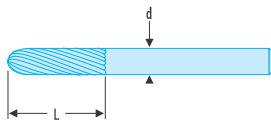

- Tungsten carbide.
- Right-hand spiral.
- Cutter shank diameter 6 mm.



Ref	d [mm]	L [mm]	No.	tr/min	ΔΔ [g]
VFA.600	6	18	1	50000	25
VFA.602	6	18	2	50000	25
VFA.604	6	18	3	50000	25
VFA.606	6	18	4	50000	20
VFA.608	6	18	5	50000	20
VFA.610	6	15	6	50000	20
VFA.1200	12	25	1	20000	55
VFA.1202	12	25	2	20000	55
VFA.1204	12	25	3	20000	50
VFA.1206	12	25	4	20000	30
VFA.1208	12	25	5	20000	35
VFA.1210	12	20	6	20000	40

229.TT - 90° cone bits

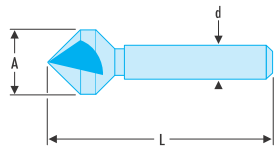

- 3 HSS cutting edges for countersunk screw holes.
- Requires a pilot hole with a cylindrical bit ref 222A.T.



Ref	A [mm]	d [mm]	L [mm]	ΔΔ [g]
229.TT2	10,4	6	50	10
229.TT3	16,5	10	60	30
229.TT4	20,5	10	63	50
229.TT5	25,0	10	67	70

90° cone bits



- Comprising:
- 4 bits: 229.TT2 --> 229.TT5 (and lubricant).
- In a steel case, dim. (L. x W. x H.): 120 x 100 x 38 mm.



Ref	H [mm]	L [mm]	ΔΔ [g]
229.TTJ4	38	120	450

SCRAPERS

Three-square scraper



- Finish: high quality steel blade, polished chrome finish and varnished wood handle.
- Shank length: 200 mm.



Ref	L [mm]	ΔΔ [g]
231	200	180

■ Half-round curved scraper

- Finish: high quality steel blade, polished chrome finish and varnished wood handle.
- Shank length: 200 mm.



🔪	L [mm]	ΔΔ [g]
232	200	180

■ Flat scraper

- Finish: high quality steel blade, polished chrome finish and varnished wood handle.
- Shank length: 200 mm.



🔪	L [mm]	ΔΔ [g]
329	200	185

■ Set of 3 stainless steel scrapers

- Stainless steel blade, thickness: 0.8 mm.
- Reinforced striking zone.
- 3 shapes:
 - Straight, width: 32 mm.
 - Straight, width: 50 mm.
 - Angled, width: 32 mm.



🔪	L [mm]	ΔΔ [g]
235.J1	215	427

■ Set of 3 flexible spatulas

- Stainless steel blade, thickness: 0.5 mm.
- 3 shapes:
 - Straight, width: 32 mm.
 - Straight, width: 50 mm.
 - Angled, width: 32 mm.
- Width: 32 - 50 - 75 mm.



🔪	L [mm]	ΔΔ [g]
237.J1	215	273



FLUO

Rfid



METAL SHEARS

883 - Scroll shears

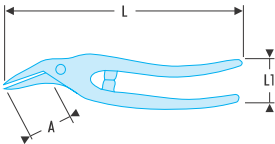

- Specially-shaped nose for accurately following detailed patterns.
- Steel end stops.
- Left-cut scroll shears: 883B.G.
- Right-cut scroll shears: 883B.
- Right cut large-capacity scroll shears: 883.32.
- Finish: Epoxy paint.



883	A [mm]	L [mm]	L1 [mm]	Capacity Semi-hard steel [mm]	Capacity Stainless [80 kg/mm ²]	ΔΔ [g]
883B.G	46	260	43 - 170	1,0	0,8	535
883B	50	260	43 - 170	1,0	0,8	530
883.32	73	320	47 - 170	1,2	0,9	765

884 - Panel shears

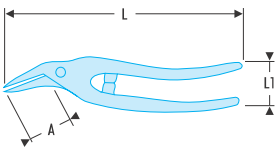

- The bottom-blade clearance makes these shears ideal for continuous straight cuts in large panels, leaving clean edges.
- Steel end stop.
- Right-hand panel shears: 884B.
- Right-hand high capacity panel shears: 884.30.
- Finish: Epoxy paint.



884	A [mm]	L [mm]	L1 [mm]	Capacity Semi-hard steel [mm]	Capacity Stainless [80 kg/mm ²]	ΔΔ [g]
884B	40	260	43 - 130	1,0	0,8	670
884.30	52	300	45 - 150	1,2	0,9	840

General-purpose shears

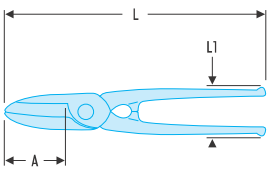

- 2 wide blades.
- Capacity:
 - Stainless 80 kg/mm²: 0.5 mm.
 - Semi-hard steel: 0.8 mm.
- Forged steel end stop.
- Finish: Epoxy paint.



880	A [mm]	L [mm]	L1 [mm]	ΔΔ [g]
880	55	260	45 --> 130	520

882A-884A - Two-hand shears

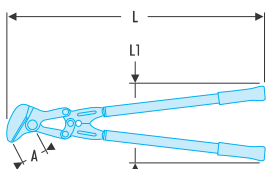

- Very high demultiplication.
- Forged steel end stop.
- Cutting capacity for blued sheet 120 kg/mm²: 2.0 mm (882A.65) and 2.5 mm (884A.65).
- Finish: Zinc-coated blades, tubular handles with neoprene grips.
- Spare blades:
 - 882A.L65 for 882A.65.
 - 884A.L65 for 884A.65.



882A	A [mm]	L [mm]	L1 [mm]	ΔΔ [kg]
882A.65	50	665	210 --> 820	2.1
884A.65	48	660	200 --> 790	2.4

METAL SHEARS

Right-cut universal scroll shears

ASME B107.500

- Demultiplication reducing efforts.
- Forged, hardened and burnished blades.
- Red sheathed grips with guard.
- Inset opening spring.
- Lock-closed catch.
- Cutting capacity.
 - Stainless 80 kg/mm²: 0.8 mm.
 - Semi-hard steel: 0.8 mm.

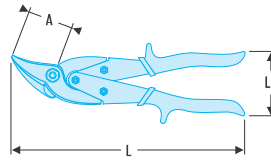
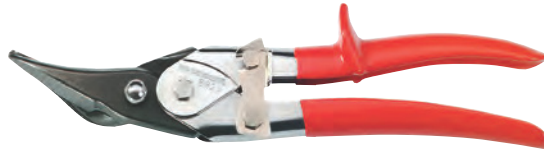

🔪	A [mm]	L [mm]	L1 [mm]	ΔΔ [g]
882A	32	250	45 - 130	475

982 - Compound scroll shears

ASME B107.500

- Panel-type shears with slightly serrated cutting edges to prevent workpiece slip.
- Good demultiplication and inset opening spring.
- Forged chrome molybdenum blades.
- Ergonomic non-slip bi-material grips.
- Colour-coded according to direction of cut.
 - Red: left cut (Ref 982.G).
 - Green: right cut (Ref 982).
- Jaw lock catch.
- Cutting capacity.
 - Stainless 80 kg/mm²: 0.8 mm.
 - Semi-hard steel: 1.2 mm.

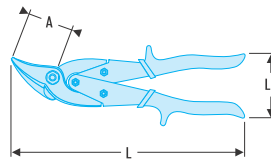

🔪	A [mm]	L [mm]	L1 [mm]	ΔΔ [g]
982	45	245	65 - 190	380
982.G	45	245	65 - 190	380

985 - "Aircraft" shears

ASME B107.500

- High demultiplication allows long runs without effort.
- Good demultiplication and inset opening spring.
- Slightly serrated cutting edges prevent workpiece slip.
- Forged chrome molybdenum blades.
- Ergonomic non-slip bi-material grips.
- Colour-coded according to direction of cut.
 - Red: left cut (Ref 985.LE).
 - Green: right cut (Ref 985.RI).
 - Yellow: straight cut (Ref 985.ST).
- Jaw lock catch.
- Cutting capacity:
 - Stainless 80 kg/mm²: 0.8 mm.
 - Semi-hard steel: 1.2 mm.

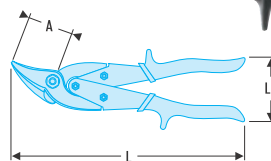

🔪	A [mm]	L [mm]	L1 [mm]	ΔΔ [g]
985.LE	55	255	60 - 150	400
985.RI	55	255	60 - 150	400
985.ST	55	255	65 - 165	390



METAL SHEARS

Nibblers

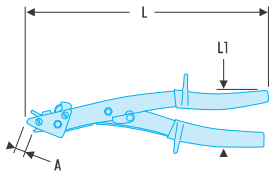
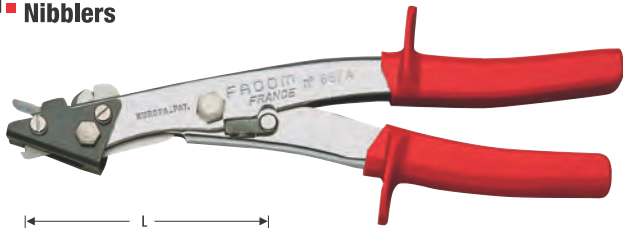

- Inset opening spring and high demultiplication allow effortless cutting along intricate patterns, removing a strip 2,8 mm wide.
- Die and blade system severs the strip at end of run.
- Top blades cut wire up to 2 mm in semi-hard steel and 2.5 mm in mild steel.
- Lock-closed catch.
- Cutting capacity.
 - Stainless 80 kg/mm²: 0,8 mm.
 - Semi-hard steel: 1 mm.
- Spare blade: 887A.L1.

	A [mm]	L [mm]	L1 [mm]	ΔΔ [g]
887A	7	260	45 - 110	520

990.B BOLT CROPPERS



Powerful

- Increased steel-cutting capacity up to 160 kg/mm².
- Available with forged arms.

Durable

- Harder blades for a more durable cut.
- Body specially treated to reduce play to a minimum.
- High performance chrome blades.
- Eccentric screw adjustment of play between blades.

Efficient

- Minimum cutting effort.
- Handgrip with guard for greater comfort

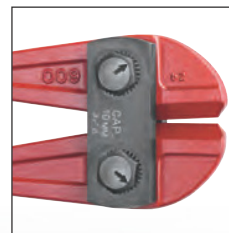
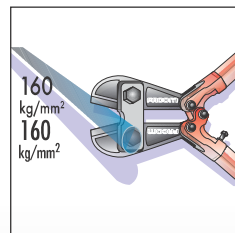

BOLT CROPPERS

BOLT CROPPERS

990.BF - Axial cut bolt croppers



- Forged arms = less cutting flexion.
- High performance chrome blades.
- Harder blades for a more durable cut.
- Eccentric screw adjustment of play between blades.
- Hand grip with guard for greater comfort.

	Ø [mm]: 60 - 140 - 160 kg/mm ²	Blade	L ["]	L [mm]	ΔΔ [kg]
990.BF0	7,0 - 6,0 - 5,5	990.LB0	18	450	1,7
990.BF1	10 - 8 - 7	990.LB1	24	600	2,8
990.BF2	13 - 9 - 8	990.LB2	30	750	4,2
990.BF3	16 - 10 - 9	990.LB3	35	900	6,4
990.BF4	18 - 11 - 10	990.LB4	41	1050	8,6

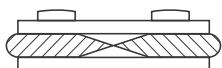

BOLT CROPPERS

■ **990.BF - Axial cut tubular arm bolt croppers**

- High performance chrome steel blades.
- Harder blades for a more durable cut.
- Eccentric screw adjustment of play between blades.
- Hand grip with guard for greater comfort.



Ø [mm]: 60 - 140 - 160 kg/mm ²	Blade	L ["]	L [mm]	ΔΔ [kg]	
990.B0	7,0 - 6,0 - 5,5	990.LB0	18	450	1,7
990.B1	10 - 8 - 7	990.LB1	24	600	2,8
990.B2	13 - 9 - 8	990.LB2	30	750	4,2
990.B3	16 - 10 - 9	990.LB3	35	900	6,4
990.B4	18 - 11 - 10	990.LB4	41	1050	8,6

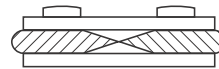

■ **990.RB0 - Flush-cut bolt croppers**

- Specific blades for high performance chrome steel flush cutting.
- Harder blades for a more durable cut.
- Eccentric screw adjustment of play between blades.
- Hand grip with guard for greater comfort.
- 990.BRF0: Forged arms.
- 990.R00 - 990.R0: Tubular arms.



Ø [mm]: 60 - 140 - 160 kg/mm ²	Blade	L ["]	L [mm]	ΔΔ [kg]	
990.RB00	6 - 5 - 5	990.LRB00	12	350	1,0
990.RB0	7,0 - 6,0 - 5,5	990.LRB00	18	450	1,7
990.BRF0	7,0 - 6,0 - 5,5	990.LRB0	18	450	1,7

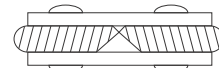

■ **990.LB - Replacement blades for series 990.B (with screws)**

- Bolt-cropper blades are consumables and subject to normal wear. Facom guarantees their conformity to dimensional standards and suitability for recommended applications.
- Actual service life is dependent on conditions of use.
- Supplied with fasteners.



For	ΔΔ [kg]	
990.LB0	990.BF0 - 990.B0	0,650
990.LB1	990.BF1 - 990.B1	1,050
990.LB2	990.BF2 - 990.B2	1,650
990.LB3	990.BF3 - 990.B3	2,400
990.LB4	990.BF4 - 990.B4	3,400
990.LRB00	990.RB00	0,450
990.LRB0	990.BRF0 - 990.RB0	0,650

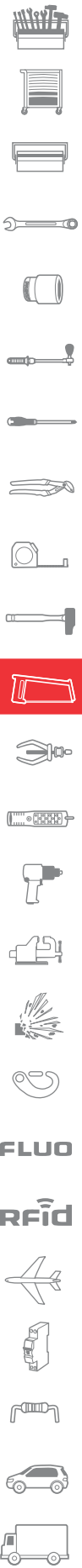

BOLT CROPPERS

Mini croppers

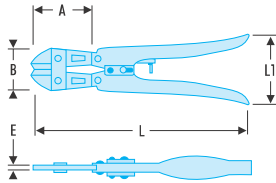

- Compact, lightweight tool with demultiplication system designed to cut hard and semi-hard wire: piano wire, bolts, rivets, pins and nails, etc.
- Forged, hardened blades.
- Cutting capacity:
 - Piano wire: max. diameter 2 mm to 200 kg/mm².
 - Soft wire: max. diameter 4 mm to 60 kg/mm².
- Ergonomic hardened pressed-steel handles with adjustable, shock-absorbing end stop.
- Spring-assisted opening.
- Blades lock in closed position.
- Finish: bronzed blades, painted grips.



🔗	A [mm]	B [mm]	E [mm]	L [mm]	L1 [mm]	ΔΔ [g]
997A.20	54,5	40	4,5	210	57	275

CABLE CUTTERS

COPPER AND ALUMINIUM CABLE CUTTERS

412 - Cable cutters

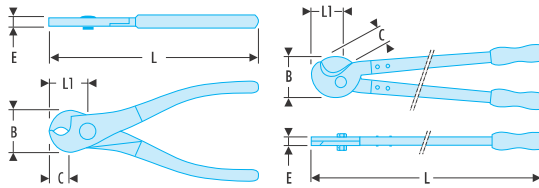

- 412B.10 "Compact" cable cutters:
 - Capacity: diameter 10 mm.
 - Integral opening spring.
 - Lock closed catch.
 - Cross proof design.
- 412.16 "Standard" cable cutters:
 - Capacity: diameter 16 mm.
 - Heavy-duty head, cross proof design.
 - Safety stop.
- 412.30 - 412.42 "Heavy-duty" cable cutters:
 - Capacity: 32 mm (Ref. 412.30) and 42 mm (Ref. 412.42).
- Powerful action, cuts without crushing electric cables.
- Safety stop.
- Set of blades for 412.30: 412.L30.
- Set of blades for 412.42: 412.L42.



🔗	B [mm]	C [mm]	d [mm]	d mini - maxi [mm]	E [mm]	L [mm]	L1 [mm]	ΔΔ [kg]
412B.10	28	21	10	53 - 190	10	170	40	0.225
412.16	54	28	16	80 - 370	14	290	45	0.670
412.30	70	40	32	155 - 1000	16	600	60	2.5
412.42	115	70	42	200 - 1300	16	800	90	3.7

413 - Ratchet cable cutters

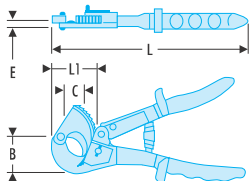

- Ratchet-blade system for easy cut through thick gauge cables.
- Particularly useful in confined spaces.
- Non-slip grips with guards.
- Capacities: 32 - 52 mm.
- Spare blade for 413A.32: 413A.L32.



🔗	B [mm]	C [mm]	d maxi [mm]	E [mm]	L [mm]	L1 [mm]	ΔΔ [g]
413A.32	58	34	32	7,8	255	65	385
413.52	80	53	52	8,0	275	75	800

COPPER AND ALUMINIUM CABLE CUTTERS

Manual 10 mm diameter copper/aluminium cable cutters

- Notched end for stripping wires.
- For single and multi-strand cables.
- Capacity:
 - Multi-strand cable: diameter 10 mm.
 - Single strand copper: diameter 8 mm.
 - Almelec: diameter 6 mm.



Image	L [mm]	ΔΔ [g]
	165	225
985912		

Manual 18 mm diameter copper/aluminium cable cutters

- Notched end for stripping wires.
- For single and multi-strand cables.
- Capacity:
 - Multi-strand cable: diameter 18 mm.
 - Single strand copper: diameter 15 mm.
 - Almelec: diameter 10 mm.

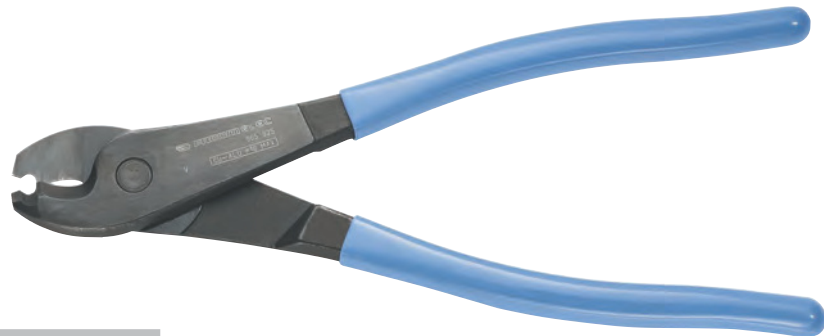

Image	L [mm]	ΔΔ [g]
	231	350
985925		

STEEL CABLE CUTTERS

"Compact" steel cable cutters

NFE 75-001, NFE 75-002

- Lightweight tool with blades and cutting angle designed for cutting solid materials and multi-strand cables.
- Push catch to lock closed, simply squeeze handles to release.
- Blades hardened to 60-62 HRC.
- Capacity:
 - 5 mm for 60 - 100 kg/mm² soft steel cable.
 - 4 mm for 130 - 160 kg/mm² hard steel cable.
 - 3 mm for 60 kg/mm² round cable.

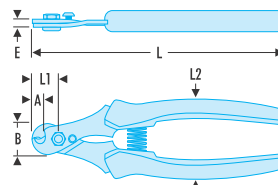

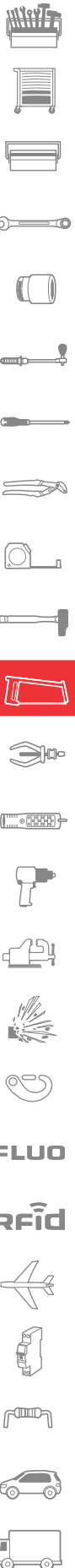
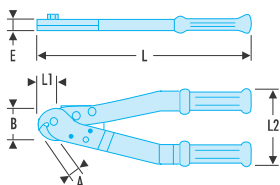

Image	A [mm]	B [mm]	E [mm]	L [mm]	L1 [mm]	L2 [mm]	ΔΔ [g]
	7	21	8	165	12	50 - 125	165
996.5							



STEEL CABLE CUTTERS

■ "Standard" steel cable cutters



NFE 75-001, NFE 75-002

- Blade inserts in high-performance steel.
- Compact and powerful with ergonomic grips.
- Capacity:
 - 8 mm for 60 - 100 kg/mm² soft steel cable.
 - 7 mm for 130 - 160 kg/mm² hard steel cable.
 - 6 mm for 60 kg/mm² round cable.
- Spare blades: 996.L8.



	A [mm]	B [mm]	E [mm]	L [mm]	L1 [mm]	L2 [mm]	ΔΔ [g]
996.8	12	42	16	340	21	115 - 470	890

■ Steel cable cutters

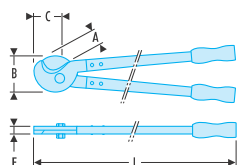

NFE 75-001, NFE 75-002

- Compact and powerful model.
- Blade inserts in high-performance steel.
- Cross proof design.
- Capacity:
 - 12 mm for 60 - 100 kg/mm² soft steel cable.
 - 10 mm for 120 - 150 kg/mm² hard steel cable.
 - 8 mm for 60 - 80 kg/mm² round cable.
- Spare blades: 996.L12.



	A [mm]	B [mm]	E [mm]	L [mm]	L1 [mm]	ΔΔ [kg]
996A.12	20	73	16	600	50	2.7

■ "Power" steel cable cutters

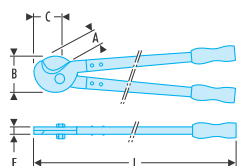

NFE 75-001, NFE 75-002

- Maximum power model.
- Forged blades in high-performance steel.
- Cross proof design.
- Ergonomic handles.
- Capacity:
 - 16 mm for 60 - 100 kg/mm² soft steel cable.
 - 13 mm for 120 - 150 kg/mm² hard steel cable.
 - 10 mm for 60 - 80 kg/mm² round cable.
- Spare blades: 996.L16.



	A [mm]	B [mm]	E [mm]	L [mm]	L1 [mm]	ΔΔ [kg]
996.16	28	115	16	800	55	5.0

UTILITY KNIVES

Retractable utility knife with interchangeable blades



- Choice of 3 blade settings.
- Moulded handle housing 5 blades.
- Zamak body.
- Zinc alloy slide-button.



Code	Weight [g]
844.R	190

18 mm automatically reloading utility knife



- Productivity, accessibility, safety.
- Automatically reloading snap-off blades.
- Ergonomic soft ABS handle.
- Stainless steel blade guide.
- Blade lock knob.
- 6-blade cartridge.
- Integral blade snapper.



Code	E [mm]	H [mm]	L [mm]	Weight [g]
844.S18	24	47	172	160

Cutter with 18 mm snap-off blades



- Cutter with snap-off blades.
- Ergonomic soft ABS handle.
- Stainless steel blade guide.
- Automatic blade lock.
- 2-blade cartridge.
- Integral blade snapper.



Code	E [mm]	H [mm]	L [mm]	Weight [g]
844.SE18	24	43	172	90

Cutter with 9 mm snap-off blades



- Cutter with snap-off blades.
- Ergonomic soft ABS handle.
- Stainless steel blade guide.
- Automatic blade lock.
- 2-blade cartridge.
- Integral blade snapper.



Code	E [mm]	H [mm]	L [mm]	Weight [g]
844.S9	17	30	149	47

BLADE SELECTION GUIDE

Our cutting tool experience at the service of professionals

A perfectly cut blade guarantees your safety

- A neat, clean cut.
- Does not damage the material to be cut.
- Effortless cutting without the risk of blade slippage or pull-out.
- Saves time.



A choice of packaging

- 10 blade dispenser always handy.

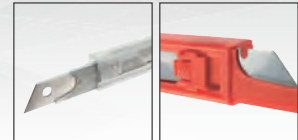

A blade is a compromise between :

- Hardness : For a strong cutting section and good stress resistance.
- Flexibility : For stress resistance as well as allowing the blade to twist without deforming for a neat cut.
- Cutting angle : to guarantee an optimum cut according to the material.

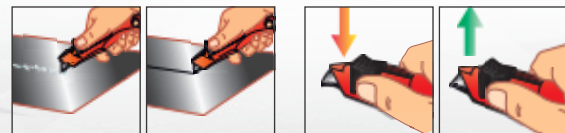

Choosing the right blade

- What material is being cut ? Material, thickness.
- On what backing surface will cutting be performed ? (Does it need protecting ?)
- Is there a risk of slipping ? (uneven surface)
- What is the work environment ?
- What is the frequency of use ?
- What is the desired durability ?

High strength perforated trapezoidal blade

- High strength trapezoidal blade.
- Designed to produce a perfect cut in intensive applications.
- Ideal for cutting: thick cardboard, hose, plastic, resilient foam, heat-shrinkable tubing, nylon strip, plastic tubes, seals.
- Supplied in a 10 blade dispenser.



	E [mm]	H [mm]	L [mm]	ΔΔ [g]
844.TTL10	0,65	19	60	50

High performance safety trapezoidal blade

- High performance trapezoidal blade.
- Rounded corner to avoid risk of accidental cutting.
- Designed to produce a perfect cut in intensive applications.
- Ideal for cutting: thick cardboard, hoses, plastic, resilient foam, heat-shrinkable tubing, nylon strip, plastic tubes, seals.
- Supplied in a 10 blade dispenser.

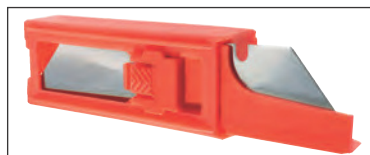

	E [mm]	H [mm]	L [mm]	ΔΔ [g]
844.TRL10	0,65	19	60	50

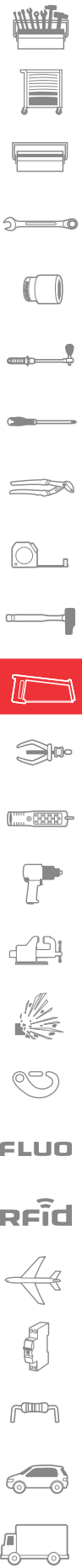

UTILITY KNIVES

■ High strength hook blade



- High strength hook blade.
- Specially designed to protect the backing during cutting.
- Ideal for cutting:
 - Floor finishes, e.g. carpet, lino, PVC or other laid material.
 - Straps and thick fabric.
- Supplied in a 10 blade dispenser.



	E [mm]	H [mm]	L [mm]	ΔΔ [g]
844.TCL10	0,65	19	50	50

■ 18 mm snap-off blades

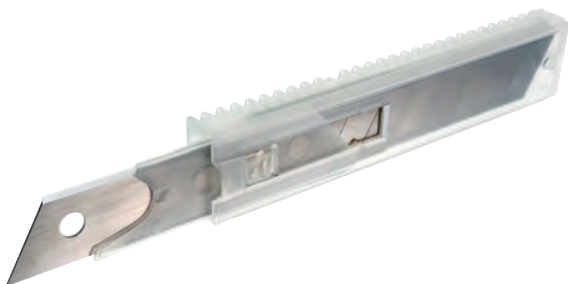

- 7-segment 18 mm snap-off blade.
- Ideal for all everyday cutting applications:
 - Thick cardboard.
 - Hose.
 - Plastic.
 - Resilient foam.
 - Heat-shrinkable tubing.
 - Nylon strip.
 - Plastic tubes.
 - Seals.
- Warning, snap-off blades are not designed to withstand excessive torsion forces.
- Supplied in a 10 blade dispenser.



	E [mm]	H [mm]	L [mm]	ΔΔ [g]
844.S18L10	0,53	18	110	90

■ 9 mm snap-off blades



- 7-segment 18 mm snap-off blade.
- Ideal for all everyday cutting applications:
 - Thick cardboard.
 - Hose.
 - Plastic.
 - Resilient foam.
 - Heat-shrinkable tubing.
 - Nylon strip.
 - Plastic tubes.
 - Seals.
- Warning, snap-off blades are not designed to withstand excessive torsion forces.
- Supplied in a 10 blade dispenser.



	E [mm]	H [mm]	L [mm]	ΔΔ [g]
844.S9L10	0,43	9,5	84	30

UTILITY KNIVES

"CUT ALL" GENERAL-PURPOSE SHEARS

An effortless clean cut every time



Aluminium sheet (up to 1 mm thick), hard metal sheet (up to 0.5 mm), PVC, cardboard, rubber, floor coverings up to 5 mm thick, hoses, plastic ties, small diameter pipes, electric cables (up to d 2.5 mm), insulating foam, wrapping paper... and many other applications.

1-Precise: serrated blades, no risk of slipping.

2-Smart: 2 opening positions, adapts to your hand. (26 mm / 36 mm).

3-Safe: Locks in closed position.

4-Comfortable: Non-slip bi-material grips.

980 - Straight serrated shears
980C - Angled serrated shears

- Ideal for cutting long lengths.
- Keeps the hand away from the cutting operation.

Multi purpose shears

- 980: straight blade version.
- 980C: angled blade version.
- Blade opening 29 to 36 mm.
- Handle opening 77 to 102 mm.
- Comfortable: non-slip bi-material grips.
- Safe: locks in closed position.
- Accurate: slightly serrated blade prevents any risk of slippage.
- Ideal for all everyday cutting applications:
 - Cardboard, rubber, PVC, leather 5 mm thick.
 - Thin sheet steel 0.5 mm thick, aluminium sheet up to 1 mm thick.
 - Electric cables up to 2.5 mm diameter.
 - Hoses, tubes, insulating foam, etc.



ED	B [mm]	C [mm]	L [mm]	ΔΔ [g]
980	67	49	205	200
980C	67	49	205	200

SCISSORS - KNIVES

Sheathed electricians scissors

- Ergonomic plastic moulded sheathing, left/right hand.
- Long blades, with wire cutter.
- Finish: bi-material grips, burnished blades.



ED	L [mm]	Blade	ΔΔ [g]
841A.4	143	45 mm	80



FLUO

Rfid



SCISSORS - KNIVES

■ Electricians scissors



- 100% metal handles, left/right hand.
- Short reinforced blades, with wire cutter.
- Finish: polished chromed.



	L [mm]	Blade	ΔΔ [g]
841	150	33 mm	95

■ Heavy Duty Scissors



- Complete structure in steel (blades + handles).
- Crimping part.
- Cabel Cutter Ø 50 mm on both blades.
- Slot for stripping cable (1,5mm - 2,5mm - 4 mm).
- Stainless Steel blade.
- Holder with belt hooking clip.
- Anti-slip ridges on rings for handhold.
- Big and small eye for large or small fingers.



	L [mm]	Blade	ΔΔ [g]
841A.3	160	40 mm	150

■ Multi-purpose scissors



- Multiple use, highly versatile and maximum comfort.
- Exclusive FACOM ergonomic grip for right-handers for better comfort.
- Ideal for cutting thick cardboard, aluminium (thickness 0.2 mm), rubber (thickness 3mm), leather (thickness: 5 mm), rope, etc.
- Stainless steel blades: precision and better durability of the cutting edge.
- Finish: bi-material grips, burnished blades.



	L [mm]	Blade	ΔΔ [g]
841A.9	255	107 mm	210

KNIVES

■ Lock-back knife with bi-material handle



- Blade in polished stainless steel. Blade partially smooth for accurate cutting and another serrated for powerful cutting.
- Quick one-handed opening.
- Knife at the tip of the knife: window breaker function.
- Safe: lock-back.
- Universal hanging hook.
- Clip at the back of the knife for direct hanging to the belt.
- Blade length 77 mm; closed length: 115 mm.
- Total length: 186 mm.
- Supplied in vertical nylon case which fastens to the belt.



	L [mm]	ΔΔ [g]
840.F	115	170

KNIVES

840 THE 100% STAINLESS STEEL KNIFE

The knife designed as a tool

Stainless steel 12C27 stainless steel blade.

Comfortable
Safe one-handed thumbwheel blade opening (left or right hand).

Universal hanging hook.

Safe blade release
Blade is closed by releasing the "liner-lock" safety catch in two stages.

Ergonomic
One-piece brushed stainless steel handle for a better grip.

• Comes with horizontal leather case for complete freedom of movement and compliance with the safety regulations.

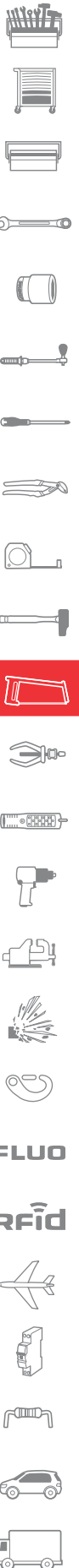

KNIVES

Thumbwheel knife

- 12C27 stainless steel construction: very high corrosion resistance. Ideal in marine environments.
- Quick one-handed opening.
- Right/left hand.
- Safe: Liner lock safety catch and 2 stage release.
- Universal hanging hook.
- Blade length 73.5 mm; closed length: 115.5 mm.
- Total length: 189 mm.
- Comes with horizontal leather case.



	L [mm]	ΔΔ [g]
840LE	115.5	250

Lock-back knife

- Polished stainless blade.
- Safe: lock-back.
- Rosewood handle and nickel silver bolster.
- Blade length 78 mm; closed length: 105 mm.
- Total length: 183 mm.



	L [mm]	ΔΔ [g]
840.4A	105	160

Twin-blade electricians knife with plastic handle

- Electricians knife with blades suitable for cable work:
 - 1 straight hollow ground general-purpose blade (length: 65 mm).
 - 1 short curved blade, specially designed for cable work (length: 35 mm).
- Safe: lock-back for each blade.
- Length closed: 104 mm.
- Total length: 131/169 mm.



	L [mm]	ΔΔ [g]
640180	104	100

KNIVES

Electricians knife with wire stripper



- Blade in polished stainless steel.
- Billhook blade.
- Wood handle.
- Blade length 60 mm; closed length: 100 mm.
- Total length: 160 mm.

	L [mm]	ΔΔ [g]
840B	100	85

Twin-blade electricians knife with wood handle



- Blades in polished stainless steel.
- Billhook blade, length 65 mm.
- Straight blade, length: 80 mm.
- Wood handle.
- Length closed: 100 mm.
- Total length: 165/180 mm.

	L [mm]	ΔΔ [g]
843	100	115

Electricians knife with wire stripper with wood handle



- Blade in polished stainless steel.
- Blade with 2 notches:
 - 1 half-moon notch for stripping.
 - 1 vee for cutting.
- Rosewood handle.
- Blade length 77 mm; closed length: 103 mm.
- Total length: 180 mm.

	L [mm]	ΔΔ [g]
840.1	180	75

PUNCH KIT

The solution to easily produce all your gaskets

- These kits are used to cut out clean and accurate circular gaskets in a variety of materials including cardboard, leather, rubber and fabric.
- To cut holes Ø 3 to 50 mm, use a punch 245A.T with a shank 245A. M.
- To cut holes Ø 44 to 420 mm, use calipers with centre-point and cutter.
- All components are available either separately or in kits.

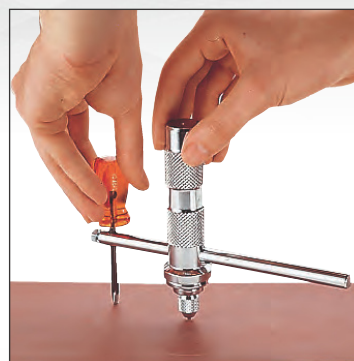

245A.T - Punches

Ø	d [mm]	Capacity Ø maxi [mm]	For	ΔΔ [g]
245A.T3	3	M13 x 100	245.J1 - 245.J2	10
245A.T4	4	M13 x 100	245.J1 - 245.J2	10
245A.T6	6	M13 x 100	245.J1 - 245.J2	15
245A.T8	8	M13 x 100	245.J1 - 245.J2	15
245A.T10	10	M13 x 100	245.J1 - 245.J2	15
245A.T12	12	21	245.J1 - 245.J2	20
245A.T14	14	28	245.J1 - 245.J2	20
245A.T16	16	21	245.J1 - 245.J2	20
245A.T18	18	21	245.J1 - 245.J2	25
245A.T20	20	21	245.J1 - 245.J2	25
245A.T22	22	31	245.J1 - 245.J2	40
245A.T24	24	31	245.J1 - 245.J2	40
245A.T26	26	31	245.J1 - 245.J2	45
245A.T28	28	31	245.J1 - 245.J2	50
245A.T30	30	31	245.J1 - 245.J2	60
245A.T32	32	41	245.J2	75
245A.T34	34	41	245.J2	80
245A.T36	36	41	245.J2	80
245A.T38	38	41	245.J2	75
245A.T40	40	41	245.J2	75
245A.T42	42	52	245.J2	100
245A.T44	44	52	245.J2	105
245A.T46	46	52	245.J2	105
245A.T48	48	52	245.J2	100
245A.T50	50	52	245.J2	100



245A.T6



245A.T22

245A.T12

Accessories for punches and calipers

Ø	No.	For	ΔΔ [g]
245A.M1	1	245.J1	450
245A.M2	2	245.J1	530
245A.M3	3	245.J1	310
245A.M4	4	245.J1 - 245.J2	150
245A.P1	5	245.J1 - 245.J2 - 245.AC	40



FLUO

Rfid





PULLERS



MECHANICAL 3-LEG PULLERS

629

Universal reversible
3-leg pullers
Slim-profile 3-leg pullers
High capacity 3-leg pullers

629
632
633



HYDRAULIC 3-LEG PULLERS

636

Pullers - hg
Hydraulic jacks and pumps

636
639



MECHANICAL 2-LEG PULLERS

641

Reversible universal 2-leg pullers
Slim-profile 2-leg pullers
Wide 2-leg pullers
U-bolt 2-leg pullers

641
643
645
646



SPECIAL GRIP BEARING PULLERS

647

Tip-type pullers, cage grip
Tip-type pullers, inside grip
Spreader-type pullers, inside grip

647
648
650



SLIDE HAMMERS

652

Slide hammers

652

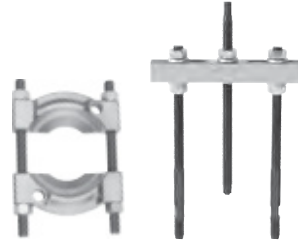

SEPARATORS AND BEAM PULLERS

653

Puller kits
Separators
Potences
Beam pullers

653
654
655
656

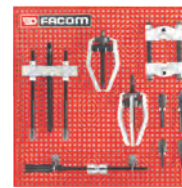

WORKSHOP EQUIPMENT KITS

657

Workshop boards
Case kits

657
658



STUD PULLERS - NUT SPLITTER

659

Stud pullers
Stud pulling
Nut splitter

659
661
662



SPARE PARTS

663



FLUO

Rfid



SELECTION GUIDE

A choice of 90 pullers for all types of components up to 800 mm.

The right questions to ask when choosing a puller

- What type of component is to be removed ? = bearing, pulley, studs or nuts.
- What is the diameter of the component to be removed ? = choice of spread.
- How is the component to be gripped ? = choice of type of grip: outside grip, inside grip, special grip.
- How is the component to be pulled ? = choice of bearing point: on the central axis, on the outside of the component, no available bearing point (= need to use puller accessories).



Icon	Spread (mm)	Reach (mm)	Force T kN	Characteristics	Page
Bearings	Pulleys	Studs	Outside grip	Inside grip	
Outside grip - adjustable 2 or 3 leg pullers					
U.306A140	7 140	147	3 30	System U.306 - 2 or 3 legs - Inside or outside grip - Self gripping - self centring	630
U.306-180	10 180	200	4 40		630
U.306-260	20 260	250	4 40		630
U.310-170	15 170	170	10 100		630
U.310-250	15 250	250	10 100		631
Outside grip - 3 leg pullers					
U.302	17 80	90	1,5 15	Compact series slim legs	632
U.302-150	25 150	150	1,5 15		632
U.302-200	25 200	200	2,4 24		632
U.20	25 170	160	7 70	Force	633
U.20B	25 260	220	7 70		633
U.27AS3	30 800	720	6 60	Heavy duty	634
U.320	100 360	400	20 200		635
U.330	100 530	550	30 300		635
U.312H	45 270	260	10 100	Heavy duty hydraulic	636
U.320H	100 360	265	20 200		638
U.330H	100 530	395	30 300		638

Inside or outside grip - 2 leg pullers						
U.32T2-8	20 80 90 140	105	2 20	Lockable reversible 2-leg puller	641	
U.32T2-12	20 120 90 180	105	2 20		641	
U.32T6-16	20 160 130 250	150	6 60		641	
U.32T6-20	20 200 130 290	150	6 60		641	
U.32T15-25	25 250 180 380	170	15 150		641	
U.32T15-35	25 350 180 480	270	15 150		641	
U.32T15-50	25 470 180 530	270	15 150		641	
U.232-65	30 60 65 90	65	1,5 15		Reversible 2-leg puller	643
U.232-90	60 81 86 95	100	3 30			643
U.232-130	60 122 86 136	100	3 30			643
U.232-160	86 153 127 171	145	4 40	643		
U.232-210	86 203 127 222	145	4 40	643		
U.232-270	100 255 148 276	190	5 50	643		
U.232-340	100 325 148 346	190	5 50	643		

SELECTION GUIDE

⇒	Spread (mm)	Reach (mm)	Force T kN	Characteristics	Page
Outside grip - 2 leg pullers					
U.14A	10 35	40	- -	Compact series slim legs	643
U.14L	10 45	60	- -		643
U.301	10 80	90	0,9 9		643
U.301-150	15 150	150	0,9 9		643
U.301-200	15 200	200	1,3 13		643
U.301P	15 50	70	0,9 10	Compact series wide legs	645
U.301M	15 100	100	0,9 11		645
U.301L	15 110	130	1,3 17		645
U.35P	10 55	75	1 10	Wide legs	645
U.35	15 75	90	4 40		645
U.35L	15 75	130	3 30		645
U.34	40 180	245	7 70		645
U.42	10 85	120	1,5 15	Slim legs with yoke	646
U.42B	10 85	180	1,5 15		646
U.52	10 150	160	6 60		646
Pulley pulling					
DM.17A	40 65	30	- -	Special for grooved pulleys: pitch=3.56 mm	23
DM.50	45 175	15	- -		
Inside grip - adaptable 2 or 3 leg pullers					
U.306A130N	23 130	140	3 30	System U.306	630
U.306-170N	50 170	190	4 40		630
U.310-230N	50 230	190	4 40		632
Special inside grip					
U.51B	32 70	-	- -		648
U.28	70 160	-	- -		649
U.49P1 → U.49P9	6 60	-	- -		650
U.23D5 → U.23D32	25 190	240	- -		647
					647
Stud extractors					
285	3 50	-	- -	Flush broken studs, right-hand	660
885	6 14	-	- -	Flush broken studs, right and left-hand thread	661
286A	5 20	-	- -	Multi-diameter tool for removing/refitting or pulling studs	661
286A.PL	15 27				
287B	6 16	-	- -	Single-diameter tool for removing/refitting or pulling studs	661
Separators - Beams - Threaded adaptors					
U.53T	5 250	-	- -	Separators	654
U.23K	25 95	150	- -	Beams	655
U.53K	40 400	350	- -		
U.53E	Ø M4-M14	-	- -	Threaded adaptors	656

Slide hammers

⇒	Compatible pullers		 Kg	Page
U.49L	U.49P1 → U.49P4	M8	0,2	652
U.49AM	U.49P5 → U.49P9	Tr1/2	1,0	652
U.306M	U.49P5 → U.49P9/U.35/U.35L/U.42/U.42L/U.32T2-8/U.32T2-12	M16	2	652
U.2/U.2A	U.20/U.20B/U.310-170/U.310-250/U.310-230N/U.32T6-16/U.32T6-20	M22	7/9,8	652

INFORMATION

The quoted pulling powers are the actual powers obtained in the laboratory under normal working conditions. All our pullers are designed to provide maximum safety and reliability.

SAFETY



As soon as access allows, use a 3-leg rather than 2-leg configuration. Check that the puller is properly aligned with the axis before applying the pulling force.

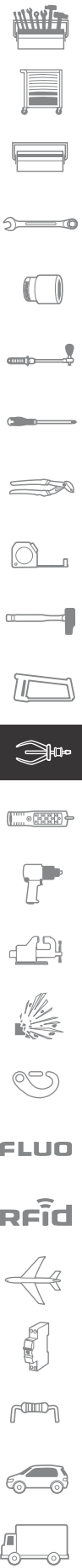

FACOM YOUR PULLER SPECIALIST

Designer and manufacturer.

A comprehensive range



Your safety: our priority.

- The design, choice of materials and optimisation of Facom's pullers ensure guaranteed safety and reliability.
- FACOM has developed a "force limiting" safety system consisting of a shear pin that fails when the maximum allowable torque is reached (series U.306/310 and U.20).



Pullers: it pays to be ready.

- Saves time: having the right puller readily to hand allows a speedy response in the event of a breakdown, and a quick resumption of production.
- A sound investment: when a machine breaks down, each second of lost production represents a great deal of money. A puller often pays for itself after just one use.

PULLERS: SAFETY FIRST

Facom's 10 tips

Pulling components can involve very high forces. The operation can therefore be very hazardous, which is why pullers require professional handling.

- 1 Wear eye protection and gloves (see section 15, p528).
- 2 Always ensure that a puller is in good condition and that the screw is evenly lubricated.
- 3 Never modify a puller. Do not grind or weld the legs. Modifications can be very dangerous for the user and invalidates the guarantee.
- 4 Wherever possible, select a 3-leg puller for optimum load distribution.
- 5 Position the legs carefully, making sure that the puller is straight in relation to the line of traction.
- 6 Where possible, use a net (or sheet) to cover both the puller and the part being removed, in case the assembly springs apart suddenly.
- 7 Before applying pressure, check that the component is free to move, i.e. that all brackets, pins and nuts have been removed.
- 8 Never stand behind a puller - stay to one side.
- 9 Ask any bystanders to keep their distance.
- 10 Apply pressure to the puller screw progressively. Do not use impact wrenches.

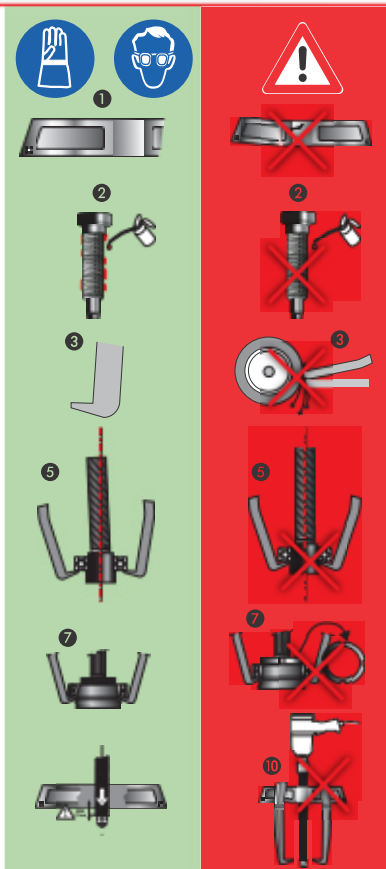

U.306/310 COVERS 80% OF COMMON APPLICATIONS



Practical, efficient, versatile

Exclusive Facom body.
Easier, safer.

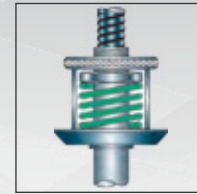

VERSATILE

- Based on a single body, the U.306/U.310 system can be configured to perform all routine mechanical engineering pulling operations.
- Puller accessories provide a full range of pulling solutions.



Inside or outside configuration for 2 or 3-leg pullers, with or without accessories.

EASY TO USE

- Self-gripping.
- Self-centering.

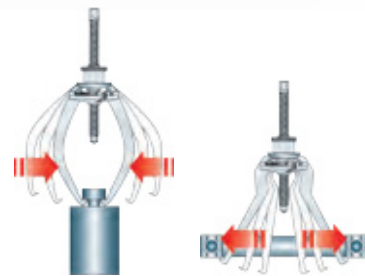

EASY LEG CHANGE

- Compress the spring.
- Remove the leg in place and place the new desired leg.

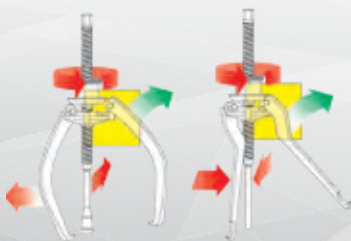

SAFETY



Locknut

- Tightening the locknut securely locks the legs in place.

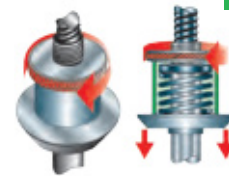

Shear pin

- The pin shears if torque limit is exceeded.



FLUO

Rfid



UNIVERSAL REVERSIBLE 3-LEG PULLERS

U.306 - Outside pullers



- Versatile: takes 2 or 3 legs. Converts into inside puller with the legs U.306G2 + screw U.306-4 or legs U.306G20 + screw U.306-2.
- Comfort: self-gripping legs by return spring. The puller stays in rolling position even when not in tension.
- Safety: legs locked in position on the bearing using a knob. No risk for the puller to escape from the bearing.
- Shear pin: the pin shears if torque limit is exceeded. Supplied with 2 spare pins.
- Set of 3 spare pins. Refer to spares table according to puller power.
- Adaptable puller accessories: slide hammer U.306M (direct attachment) and beam U.40 (attached using ring and nut U.306A1 to be ordered separately).
- The U.306-260 puller is supplied with the U.306-3 screw fitted with its extension.

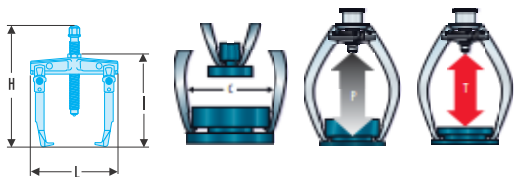

Model	C mini - maxi [mm]	H [mm]	I [mm]	L [mm]	P maxi [mm]	Legs	Tonnes [t]	T [kN]	Screw Size	Screw Size[mm]	$\Delta\Delta$ [kg]
U.306A140	7 - 140	262	225	130	147	U.306G1	3	30	U.306-4	18	1.6
U.306-180	50 - 170	320	185	135	200	U.306G10	4	40	U.306-2	18	2.2
U.306-260	20 - 260	385	350	145	250	U.306G15	4	40	U.306-3	18	3.1

U.306N - Inside pullers



- Versatile: takes 2 or 3 legs. Converts into outside puller with the legs U.306G1 + screw U.306-4 or legs U.306G10 + screw U.306-2 or legs U.306G15 + screw U.306-3 (supplied fitted with its extension).
- Comfort: self-gripping legs by return spring. The puller stays in rolling position even when not in tension.
- Safety: legs locked in position on the bearing using a knob. No risk for the puller to escape from the bearing.
- Shear pin: the pin shears if torque limit is exceeded. Supplied with 2 spare pins.
- Set of 3 spare pins. Refer to spares table according to puller power.
- Adaptable puller accessories: slide hammer U.306M (direct attachment) and beam U.40 (attached using ring and nut U.306A1 to be ordered separately).

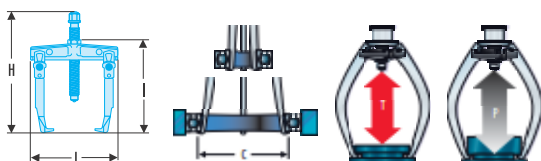

Model	C mini - maxi [mm]	H [mm]	I [mm]	L [mm]	P maxi [mm]	Legs	Tonnes [t]	T [kN]	Screw Size	Screw Size[mm]	$\Delta\Delta$ [kg]
U.306A130N	23 - 130	250	225	130	140	U.306G2	3	30	U.306-4	18	1.3
U.306-170N	50 - 170	320	285	135	190	U.306G20	4	40	U.306-2	18	1.8

Inside/outside puller kit

- Comprising:
 - 1 puller U.306A140.
 - 3 inside legs U.306G2.
 - 2 puller accessories: slide hammer U.306M and beam U.40 (attached using ring and nut U.306A1, supplied with the kit).
- Spread:
 - Outside: Ø 7 to Ø 140 mm.
 - Inside: Ø 23 to Ø 130 mm.
- Reach: 140 mm.
- Supplied in a steel case BT.102 with tray PL.209.



	$\Delta\Delta$ [kg]
U.306J1	11.3

Inside/outside puller kit

- Comprising:
 - 1 puller U.306A140.
 - 3 inside legs U.306G2.
 - 3 long-reach outside legs U.306G10.
 - Spread: outside Ø 7 to 140 mm or Ø 10 to 180 mm, inside 23 to 130 mm.
- 1 compact puller U.14L.
- Spread Ø 10 to 45 mm.
- Tray PL.354.



	H [mm]	I [mm]	L [mm]	$\Delta\Delta$ [kg]
MOD.U306	40	350	435	4.4

U.310 - Outside pullers

- Versatile: takes 2 or 3 legs. Converts into inside puller with the legs U.306G3 + screw U.20B1.
- Comfort: self-gripping legs by return spring. The puller stays in rolling position even when not in tension.
- Safety: legs locked in position on the bearing using a knob. No risk for the puller to escape from the bearing.
- Adaptable puller accessories: hydraulic screw U.3 and slide hammer U.2.

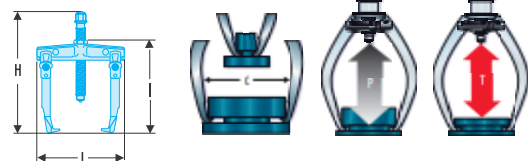

	C mini - maxi [mm]	H [mm]	I [mm]	L [mm]	P maxi [mm]	Legs	Tonnes [t]	T [kN]	Screw Size	Screw Size[mm]	$\Delta\Delta$ [kg]
U.310-170	15 - 170	365	300	143	170	U.310G1	10	100	U.20B1	24	4.6
U.310-250	15 - 250	420	380	163	250	U.310G2	10	100	U.310-250-10	24	5.6

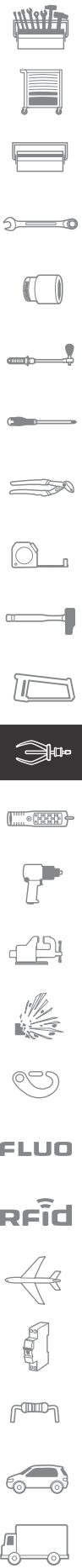

UNIVERSAL REVERSIBLE 3-LEG PULLERS

Inside puller



- Versatile: takes 2 or 3 legs. Converts into outside puller with the legs U.306G1 + screw U.20B1 or legs U.310G2 + screw U.310-250-10.
- Comfort: self-gripping legs by return spring. The puller stays in rolling position even when not in tension.
- Safety: legs locked in position on the bearing using a knob. No risk for the puller to escape from the bearing.
- Adaptable puller accessories: hydraulic screw U.3 and slide hammer U.2.

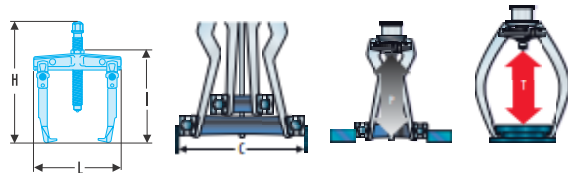

Model	C mini - maxi [mm]	H [mm]	I [mm]	L [mm]	P maxi [mm]	Legs	Tonnes [t]	T [kN]	Screw Size	Screw Size[mm]	ΔΔ [kg]
U.310-230N	50 - 230	400	360	180	200	U.310G3	10	100	U.20B1	24	4.1

SLIM-PROFILE 3-LEG PULLERS

U.302 - Self-gripping outside pullers with slim legs



- Comfort: self-gripping legs by return spring. The puller stays in rolling position even when not in tension.
- Adaptable puller accessories: slide hammer U.49AM.
 - Per tip U.301E1 (U.302 and U.302-150).
 - Per tip U.301E2 (U.302-200).

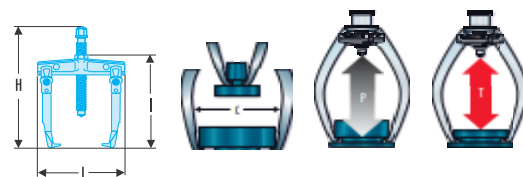

Model	C mini - maxi [mm]	H [mm]	I [mm]	L [mm]	P maxi [mm]	Legs	Tonnes [t]	T [kN]	Screw Size	Screw Size[mm]	ΔΔ [kg]
U.302	17 - 80	153	130	77	90	U.301G	1,5	15	U.301-04	10	0.6
U.302-150	25 - 150	222	206	90	150	-	1,5	15	U.301-04-150	10	0.9
U.302-200	25 - 200	300	270	105	200	-	2,4	24	U.301-04-200	13	1.6

HIGH CAPACITY 3-LEG PULLERS

Reversible universal 2-leg pullers

- Safety: legs locked in position on the bearing using the central nut. No risk for the puller to escape from the bearing.
- Shear pin: the pin shears if torque limit is exceeded. Supplied with 2 spare pins.
- Set of 3 spare pins. U.306-24J3.
- Fitted with the anti-rotation bush U.20-12. The button protects the screw when a bar is used to block puller rotation.
- Adaptable puller accessory: slide hammer U.2.

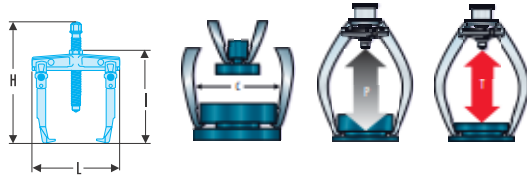

Model	C mini - maxi [mm]	H [mm]	I [mm]	L [mm]	P maxi [mm]	Legs	Tonnes [t]	T [kN]	Screw Size	Screw Size[mm]	ΔΔ [kg]
U.20	25 - 170	305	265	120	160	U.20SE4	7	70	U.20-1S	24	3.5

Long-reach leg outside puller

- Safety: legs locked in position on the bearing using the central nut. No risk for the puller to escape from the bearing.
- Shear pin: the pin shears if torque limit is exceeded. Supplied with 2 spare pins.
- Set of 3 spare pins. U.306-24J3.
- Fitted with the anti-rotation bush U.20-12. The button protects the screw when a bar is used to block puller rotation.
- Adaptable puller accessory: slide hammer U.2.

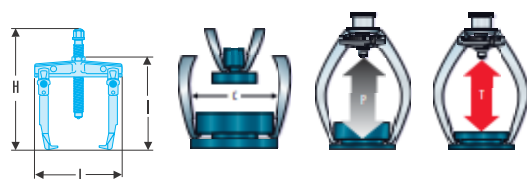

Model	C mini - maxi [mm]	H [mm]	I [mm]	L [mm]	P maxi [mm]	Legs	Tonnes [t]	T [kN]	Screw Size	Screw Size[mm]	ΔΔ [kg]
U.20B	25 - 260	370	325	125	220	U.20BSE4	7	70	U.20-B1S	24	4.3

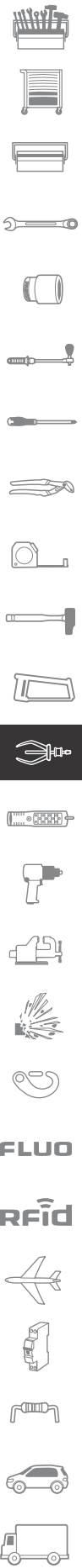

HIGH CAPACITY 3-LEG PULLERS

U.27AS3 ATTACHMENT OPTIONS

Long legs and links for increased versatility

U.27AS3

Fitted with standard legs and links.

- Spread: 30 to 460 mm.
- Max. reach: 360 mm.

3 x U.27D:

Fitted with long legs

- Spread: 40 to 460 mm.
- Max reach: 480 mm.

3 x U.27B:

Fitted with long links

- Spread: 50 to 800 mm.
- Max reach: 600 mm

3 x U.27D

+ 3 x U.27B:

Fitted with long legs and links.

- Spread: 50 to 800 mm.
- Max reach: 720 mm.



Wide spread grip puller - 2 or 3 leg pullers

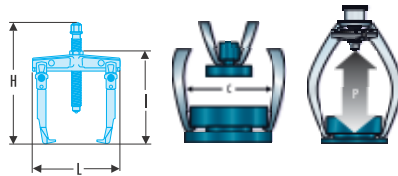

- Versatile: takes 2 or 3 legs.
- Can be fitted with long legs U.27D (order by sets of 3) and linkage system U.27B (order by sets of 3).



	C mini - maxi [mm]	H [mm]	L [mm]	L [mm]	P [mm]	P maxi [mm]	Spare Links	Legs	Tonnes [t]	T [kN]	Screw Size	Screw Size [mm]	ΔΔ [kg]
U.27AS3	30 - 460	555	450	280	360	360	U.27BS	U.27S	6	60	U.27-6	35	16.5

1 long leg for U.27AS3



- Long links designed to increase spread of puller U.27AS3 from 360 to 480 mm (order by set of 3).
- Supplied without shaft.
- Set of pins to order separately: U.27SE2.



	C mini - maxi [mm]	P maxi [mm]	ΔΔ [kg]
U.27D	40 - 460	480	1.5

1 long leg for U.27AS3

- Long links designed to increase spread of puller U.27AS3 from 460 to 800 mm (order by set of 3).
- Supplied without shaft.
- Set of pins to order separately: U.27SE2.



U.27B	C mini - maxi [mm]	P maxi [mm]	ΔΔ [kg]
	50 - 800	600	3.2

High-capacity 20T outside puller

- Versatile: takes 2 or 3 legs.
- Comfort: self-gripping legs by return spring. The puller stays in rolling position even when not in tension.
- Safety: legs locked in position on the bearing using a knob. No risk for the puller to escape from the bearing.
- The screw is supplied with an extension: U.320-14.
- Adaptable puller accessory: hydraulic jack UWG.320. Using the jack requires the screw UWG.320-H01 and hydraulic pump UWP.10M. Mounting with 3 legs only with the hydraulic jack.



U.320	C mini - maxi [mm]	H [mm]	I [mm]	L [mm]	P maxi [mm]	Legs	Tonnes [t]	T [kN]	Screw Size	Screw Size [mm]	ΔΔ [kg]
	100 - 360	740	700	250	400	U.320-13A	20	200	U.320-01	36	27.4

High-capacity 30T outside puller

- Versatile: takes 2 or 3 legs.
- Comfort: self-gripping legs by return spring. The puller stays in rolling position even when not in tension.
- Safety: legs locked in position on the bearing using a knob. No risk for the puller to escape from the bearing.
- The screw is supplied with an extension: U.330-14.
- Adaptable puller accessory: hydraulic jack UWG.330. Using the jack requires the screw UWG.330-H01 and hydraulic pump UWP.10M. Mounting with 3 legs only with the hydraulic jack.

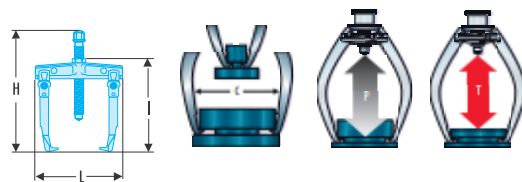

U.330	C mini - maxi [mm]	H [mm]	I [mm]	L [mm]	P maxi [mm]	Legs	Tonnes [t]	T [kN]	Screw Size	Screw Size [mm]	ΔΔ [kg]
	100 - 530	950	900	300	550	U.330-08	30	300	U.330-02	41	32.4

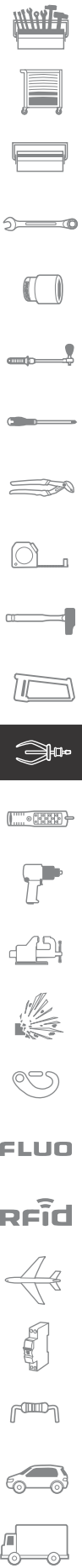

PULLERS - HG

U.312H MEDIUM-DUTY HYDRAULIC PULLER



10 tonnes of effortless pulling force readily to hand

VERSATILE

Based on a single body that can be fitted with 4 different sizes of legs for bearings Ø 45 to 270 mm. 2 or 3-leg configurations. For light to heavy engineering applications.

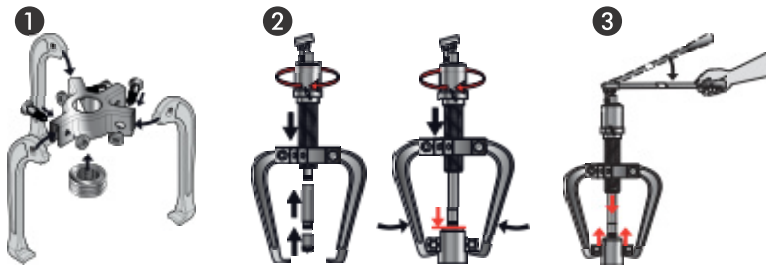

- 1 Assemble the body and the correct legs for the bearing.
- 2 Position the jack and the puller. Pump the jack. The bearing will be removed safely and effortlessly.
- 3



PRACTICAL

The carry case (field servicing) dismantles for easy storage in the drawers of your FACOM JET XL, JET+ roller cabinets (workshop servicing).



SAFETY FIRST



- A safety valve hydraulically limits the jack to 10 tonnes.
- The other mechanical components can withstand much higher forces.



Hydraulic puller 10 T for outside puller - 3 sets of legs

- Versatile: takes 2 or 3 legs.
- Safety: power is limited hydraulically to 10 tonnes. No risk of breakage.
- Comprising:
 - A 10-tonne hydraulic jack (100 kN) U.312-01 + and guide tip U.312-02 + set of 2 extensions U.312-03.
 - A body with 2 or 3 legs U.312-04 + centering screw U.312-04-01 + set of 3 screws/nuts U.312-04-02.
 - 3 sets of legs: U.312G160, U.312G210 and U.312G260.
- Supplied in plastic case U.312VAL.



	H [mm]	I [mm]	L [mm]	ΔΔ [kg]
U.312HJ3	105	412	565	13.2

U.312HJ3 - Mounting with legs

	A [mm]	C mini - maxi [mm]	H [mm]	I [mm]	L [mm]	P maxi [mm]	Tonnes [t]	T [kN]	ΔΔ [kg]
U.312G160	7	80 - 170	400	220	218	160	10	100	0.6
U.312G210	7	90 - 210	450	270	275	210	10	100	0.7
U.312G260	7	110 - 270	492	312	330	260	10	100	1.0

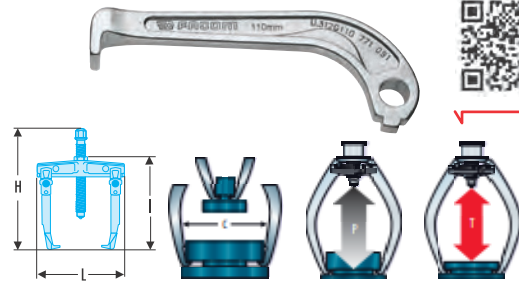

Hydraulic puller 10 T for outside puller - 4 sets of legs

- Versatile: takes 2 or 3 legs.
- Safety: power is limited hydraulically to 10 tonnes. No risk of breakage.
- Comprising:
 - A 10-tonne hydraulic jack (100 kN) U.312-01 + and guide tip U.312-02 + set of 2 extensions U.312-03.
 - A body with 2 or 3 legs U.312-04 + centering screw U.312-04-01 + set of 3 screws/nuts U.312-04-02.
 - 4 sets of legs: U.312G110, U.312G160, U.312G210 and U.312G260.
- Supplied in plastic case U.312VAL.



	H [mm]	I [mm]	L [mm]	ΔΔ [kg]
U.312HJ4	105	412	565	14.4

U.312HJ4 - Mounting with legs

	A [mm]	C mini - maxi [mm]	H [mm]	I [mm]	L [mm]	P maxi [mm]	Tonnes [t]	T [kN]	ΔΔ [kg]
U.312G110	7	45 - 85	355	175	155	110	10	100	0.4
U.312G160	7	80 - 170	400	220	218	160	10	100	0.6
U.312G210	7	90 - 210	450	270	275	210	10	100	0.7
U.312G260	7	110 - 270	492	312	330	260	10	100	1.0

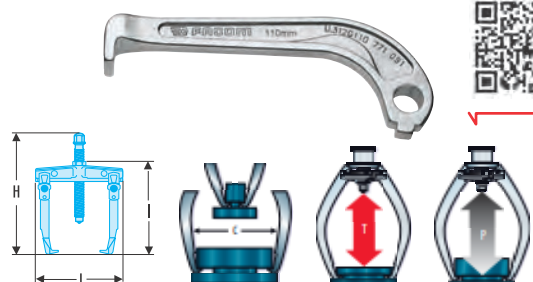

HYDRAULIC PULLERS

U.320H/U.330H HIGH CAPACITY HYDRAULIC PULLERS

Up to 30 tonnes in complete safety

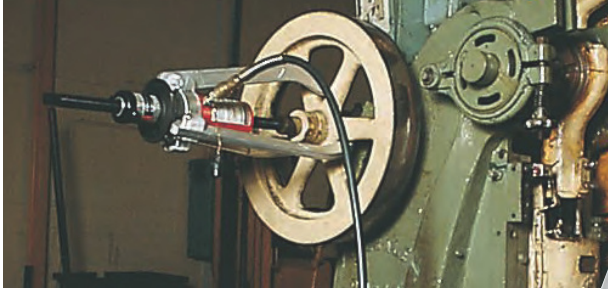

Hydraulic models incorporate a hydraulic jack fitted with a standard male coupling. The jack is designed for pressures up to 700 bar and is supplied from a manual or powered pump. Details of these accessories can be found under "Pumps and jacks".



Powerful
Fluid power ensures effortless and fast removal, while the puller remains steady even when applied to rotating components. Hydraulic models are used only with 3 legs.



Safe
• Legs are secured with a locknut.

Automatic
• Self-centring.
• Self-gripping.

20 T hydraulic outside puller



- Comfort: self-gripping legs by return spring. The puller stays in position on the bearing even when not in tension.
- Safety: power is limited hydraulically by the pump. No risk of breakage.
- 1 hollow jack UWG.320 fitted with the screw UWG.320H01.
- Use with 700-bar pump UWP.10MA.
- Mounting with 3 legs only with the hydraulic jack.



	C mini - maxi [mm]	H [mm]	I [mm]	L [mm]	P maxi [mm]	Legs	Tonnes [t]	T [kN]	Jack	Screw Size	Screw Size [mm]	$\Delta\Delta$ [kg]
U.320H	100 - 360	740	700	250	265	U.320-13A	20	200	UWG.320	UWG.320H01	21	48.5

30 T hydraulic outside puller



- Comfort: self-gripping legs by return spring. The puller stays in position on the bearing even when not in tension.
- Safety: power is limited hydraulically by the pump. No risk of breakage.
- 1 hollow jack UWG.320 fitted with the screw UWG.330H01.
- Use with 700-bar pump UWP.10MA.
- Mounting with 3 legs only with the hydraulic jack.



	C mini - maxi [mm]	H [mm]	I [mm]	L [mm]	P maxi [mm]	Legs	Tonnes [t]	T [kN]	Jack	Screw Size	Screw Size [mm]	$\Delta\Delta$ [kg]
U.330H	100 - 530	950	900	300	395	U.330-08A	30	300	UWG.330	UWG.330H01	24	55.6

HYDRAULIC JACKS AND PUMPS

10T hydraulic jack for U.312H

- Hydraulic jack: power 10 tonnes (100 kN).
- Beam travel: 80 mm.
- Use with hydraulic puller U.312H in kits U.312HJ3 and U.312HJ4.
- Supplied with guide bit U.312-02.

	d1 [mm]	d2 [mm]	L [mm]	L1 [mm]	L2 [mm]	ΔΔ [kg]
U.312-01	61	42	325	83	80	2,3

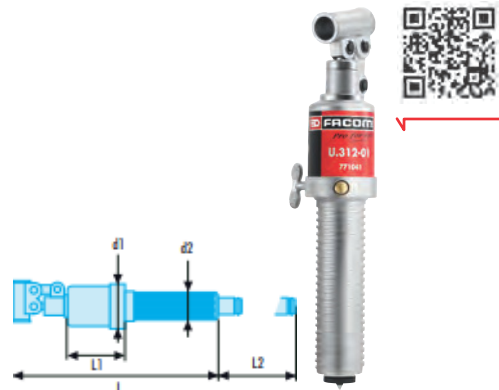

UWG - 20T and 30T hollow jacks for U.320H, U.330H

- These jacks are intended for hydraulic pullers U.320H and U.330H in replacement or option on manual pullers U.320 and U.330 using special screws UWG.320H01 and UWG.330H01.
- They are fitted with through taps receiving a central screw to work in pushing or traction.
- Jacks activated with 700-bar pump UWP.10MA.
- The use in jack function is possible.

	d [mm]	d1 [mm]	H [mm]	Oil Capacity [cm³]	Travel [N.m]	Rating [kN]	Tonnes [t]	T [kN]	Screw Size	Screw Size [mm]	ΔΔ [kg]
UWG.320	100	23,8	160	141,5	50	200	20	200	UWG.320H01	21	8,0
UWG.330	115	29,0	177	257,4	60	300	30	300	UWG.330H01	24	10,0

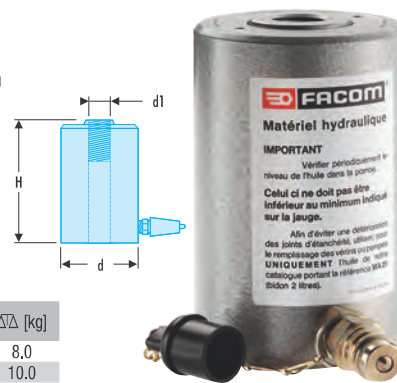

Screws for UWG jack

	d [mm]	L [mm]	Jack	Screw Size [mm]	ΔΔ [kg]
UWG.320H01	M27 x 3,0	590	UWG.320	21	2,3
UWG.330H01	M33 x 3,5	780	UWG.330	24	4,5



10 T hydraulic screw

- Power: 10 tonnes (100 kN).
- Length of the threaded screw: 300 mm.
- Travel of the pusher bit: 14 mm.
- M22 x 2.0 thread compatible with puller U.310.

	d [mm]	d1 [mm]	d2 [mm]	L [mm]	L1 [mm]	L2 [mm]	L3 [mm]	ΔΔ [kg]
U.3	14	70	M22 x 2,0	555	300	230	7 --> 21	4,5

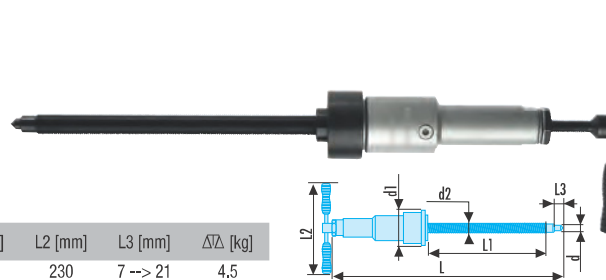

2-speed hydraulic hand pump

- Manual pump with pressure gauge and relief valve, giving 2 flow rates:
 - 1st stage: high flow, max pressure: 50 bar.
 - 2nd stage: low flow, max pressure: 700 bar.
- Use with pullers U.320H, U.330H and hollow cylinders UWG.320, UWG.330.
- Oil capacity: 1500 to 2500 cm³.
- Supplied with a 1.80 m hose with a female quick coupler WA.1166F.
- Size: 450 x 170 x 160 mm.

	l [mm]	L [mm]	ΔΔ [kg]
UWP.10MA	170	450	12,5

