



























**SPECIAL TOOLS FOR
PASSENGER CARS
&
LIGHT COMMERCIAL VEHICLES**

1		BODYWORK AND INTERIOR
2		ENGINE - ENGINE COOLING SYSTEM
3		ENGINE - HOSE CLAMP PLIERS
4		ENGINE - FUEL SYSTEM
5		ENGINE - CYLINDER HEAD / ENGINE BLOCK
6		ENGINE - TURBOCHARGER
7		ENGINE - FUEL INJECTION SYSTEM
8		ENGINE - SPARK PLUGS
9		ENGINE - GLOW PLUGS
10		ENGINE - AUXILIARY DRIVE BELT / ALTERNATOR
11		ENGINE TIMING TOOLS
12		EXHAUST SYSTEM / CATALYSERS
13		AIR CONDITIONING
14		BATTERY SERVICE
15		ELECTRICAL / ELECTRONIC TOOLS
16		HYBRID / HIGH-VOLTAGE TOOLS
17		GEARBOX
18		CLUTCH
19		SPRINGS / SHOCK ABSORBERS
20		STEERING AND STEERING GEOMETRY
21		AXLE
22		AUTO GLASS
23		BRAKE SERVICE
24		OIL SERVICE
25		WHEEL / TYRE FITTING
26		GENERAL WORKSHOP REQUIREMENTS
I		INDEX



Innovation is
our mission!

PRECISELY TAILORED REPAIR SOLUTIONS IDEALLY DESIGNED FOR THE NEEDS OF THE PROFESSIONAL

We thank the long-term loyalty and satisfaction of our global customers for our fast-paced success story. For 23 years KS Tools, as a modern special tool supplier, has been providing up-to-date solutions to problems and intelligent, time-saving tools for the constantly growing demands of our highly technical workshop routine thereby accelerating your working procedures and with it contributing to your economic success.

The countless users of our tools appreciate that as early as the development phase we set the greatest store in innovation, ergonomics, the highest level of resilience, longevity, safety and daily reliability – premium quality at a special price /performance ratio – for mature products which simplify your work in the repair shop thereby creating the basis for time and cost effective vehicle repairs.

With our logistics centre we guarantee the most reliable delivery capability with a global quick service. This means our customers gain time and receive additional benefits. More than 230 employees work in our central administration building on 2000 m² of the most modern office space and our high rack logistics centre with more than 9000 m² warehouse space and ensure every day that our customers are supplied with over 32,000 products from a single source. Currently we employ more than 350 people globally.

The signs of growth continue, more and more specialised trade partners could be gained and now enjoy the benefits of our comprehensive programme. In the process the range of services is redefined almost every day. We're precisely where you need us – today we export to more than 110 countries. The global market for professional mechanics of the automotive and commercial vehicle industry and after sales market is served through retailers with premium quality tools and workshop solutions. Together with specialised trade we delight discerning customers worldwide. Lasting partnership-based relationships are therefore of special importance to us.

Our "infomobile" fleet which we also like to use as a mobile exhibition and the experienced, qualified technicians we see, together with our specialist distributors, as a reliable interface between problems with vehicle repair and a fast and ideal solution. The technicians manning the "infomobile" fleet are experts and know your everyday problems. They are your direct line to solving the problem. Even after purchase, our qualified technicians will be there for you in word and deed.

Through our ongoing customer retention we experience more about customer requests and the desired trends of tomorrow today. In order to continue to follow our development we have significantly increased the variety of our programme and optimised it in a user-oriented way. Using modern visuals, we present you with the K15 Special Tool Catalogue for car and van on over 750 pages and covering over 10,000 chosen special tools from our entire product range of more than 32,000 products from our world of premium tools for the car and utility vehicle trades with a large spectrum of classic, modern and innovative hand tools and special tools of all kinds. Our customers can always rely on the highest level of service and delivery quality from our "One stop shop".

Our refined article categorisation, now in 26 chapters and 489 product groups will guide your fingers even more quickly to the tool group and special tool for which you are searching. We have set enormous store on the abundance of areas of application and description. In this way you will also always find the optimum tool matching your specialist application even in the case of unusual requirements. Also, with the help of the comprehensive subject index in the annex you will find the desired quality tool quickly..

Whilst we are pleased at the rapid development, we do not forget who we need to thank for this success. You, our customers and partners, have encouraged us and our employees to continue to expand our range with your confidence and your willingness to cooperate as a partner.

We would also like to continue to live up to this confidence – as according to our motto

KS — competence and service at its best.



CENTRAL ADMINISTRATION AND LOGISTICS CENTRE



*Innovation is
our mission!*



three administration buildings with **2000m²** office area





9000m²
warehouse and logistics
centre



230 highly qualified employees



22 apprentices in different occupations



Werkzeuge-Maschinen GmbH
Seligenstädter Grund 10 - 12
D- 63150 Heusenstamm



DEUTSCHLAND

Tel.: +49 6104 4974-0
Fax: +49 6104 4974-11
e-mail: kstools@kstools.de
URL: www.kstools.de

HISTORY / DEVELOPMENT



Innovation is our mission!

1992

KS Tools was founded by Mr. Peter Kühne and Mr. Stephan Schott in Offenbach as a commercial enterprise for quality tools.

1996

KS Tools moves premises to in Obertshausen with 20 employees.

1998

Premises extended with now 38 employees.

2001

New office and central warehouse with 62 employees in Heusenstamm.

2006

Following the growth of the business, KS Tools expands to 110 employees, with warehouse space of 5000 m² and office space of 1800 m².

2008 / 2009

Extension of our warehouse about 4000 m².
Building of a new training center and extension of the office space.

2009

Commissioning of the training centre.

2013

KS Tools is now expanding to 205 employees.

2014

Expansion of the goods range to 32,000 articles.

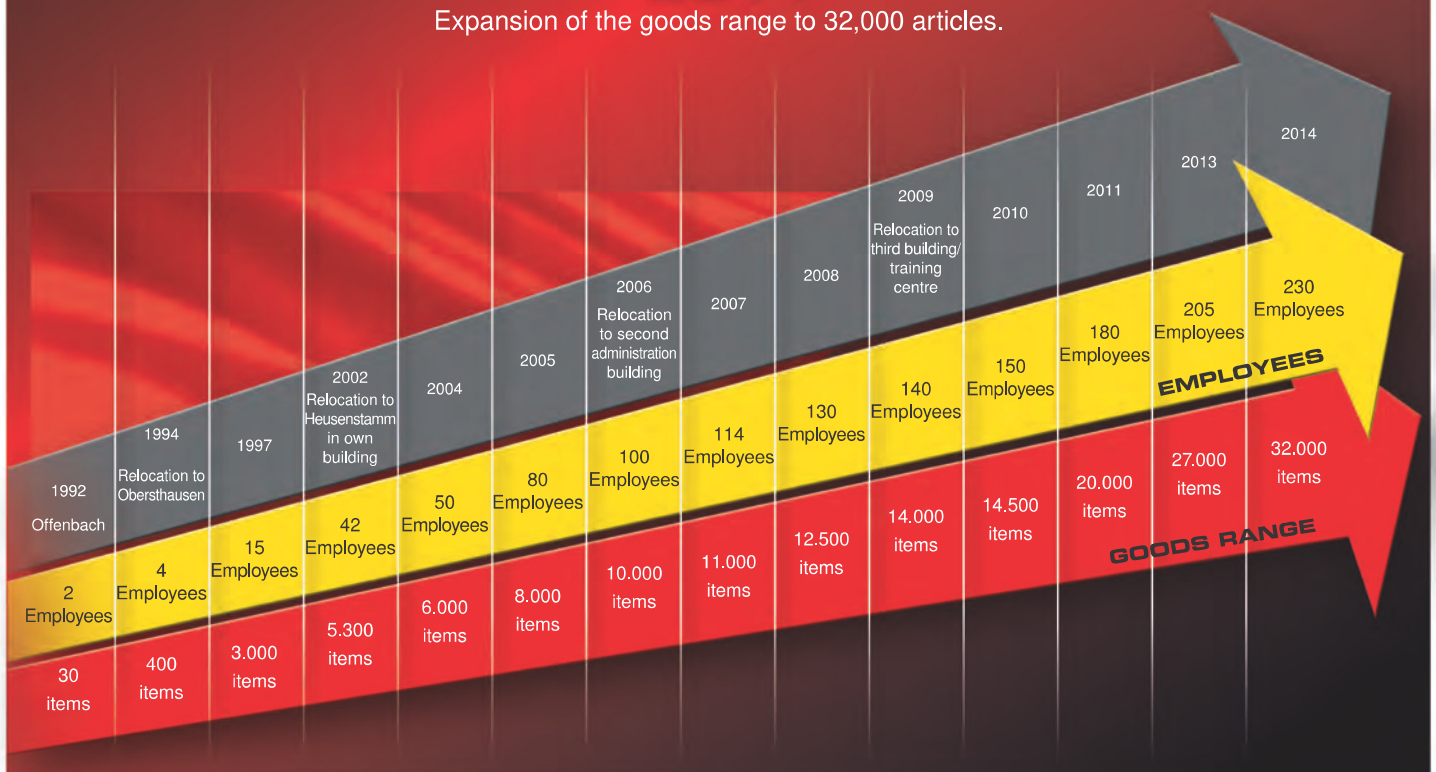

DESIGN AND BRAND PATENTS



Innovation is our mission!



is known and renowned worldwide for its innovative strength. Over the past few years this has led to numerous protective rights, on a national and a global level.



**WE ARE THERE FOR YOU —
IF YOU NEED US**



*Innovation is
our mission!*



LIGHTNING LOGISTICS — GLOBAL QUICK SERVICE

Gain time and additional benefits from our reliable shipping logistics.

Warehouse floor area



Working hours:



Euro-pallets storage:



Small parts storage:



Monthly pick position:



Monthly shipping capacity:



SALES AND DISTRIBUTION WORLDWIDE



*Innovation is
our mission!*



PREMIUM QUALITY TOOLS

Available in more than 110 countries worldwide.



EXHIBITIONS & FAIRS



KS Tools is present at more than 40 national and international fairs / exhibitions throughout the year. Use the opportunity to visit us and see first hand the quality and service which KS Tools has to offer.





Innovation is our mission!



We will be in your area soon and look forward to seeing you

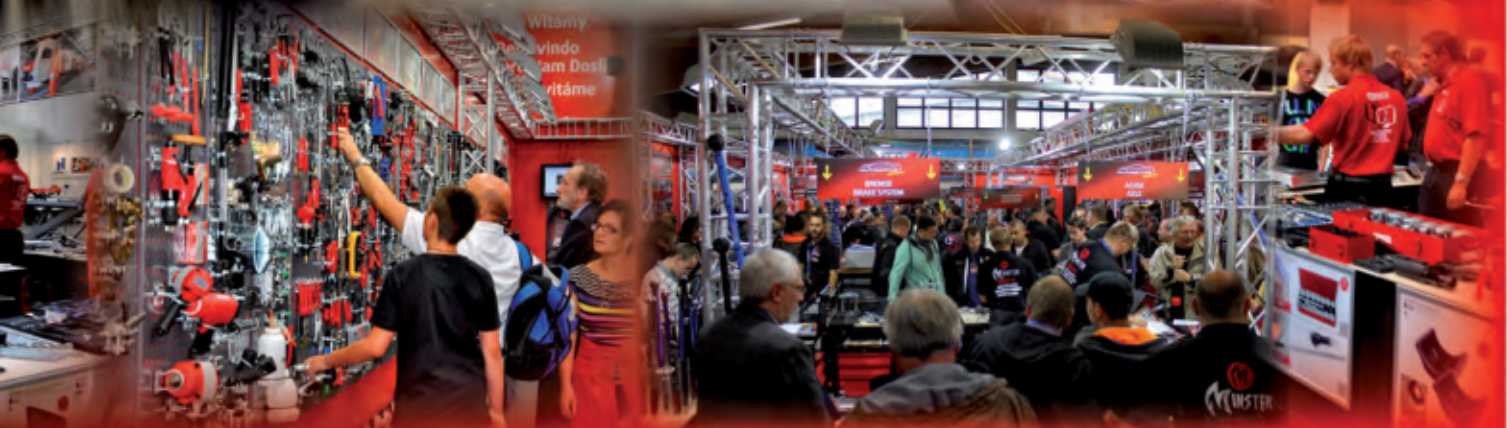

TechnicalTimes



Innovation is
our mission!



Twice a year we have our special promotion for the motor industry on at least 32 pages with a very large range of classic, modern and innovative hand tools and special tools of outstanding quality at a very good price/performance ratio.

Highly topical, problem solving solutions, and valuable usage tips - that is the TechnicalTimes!



www.toolchannel.com



Moving pictures say more than words ...

Innovation is our mission!

TOOL CHANNEL



YouTube



www.kstools.com

Herzlich Willkommen

Welcome

Bienvenido! 欢迎!

Witamy

Welkom! ようこそ!

bem vindos!

Benvenuti!

Velkommen

välkommen!

Bine ați venit

وسهل آ اول آ

Καλώς ήρθατε!

Bi xêr hatî

Tervetuloa!

добро пошли

ک مپان ای

HOŞGELDİNİZ!

Bienvenue

Vitáme vás!

bem vindos!



TRAINING CENTRE



Modern, intelligent tool systems require a high technical knowledge in order to communicate the advantages and the problem solving potential of these products to the user.
At the end of August 2009 our new

TECHNICAL TRAINING CENTRE

was handed over to his task.

On over approx. 600 square metres of presentation everything can be found for our customers, distribution partners and colleagues, as we say „all from one hand“



Core areas are

10 product islands.

The special tools are available at the same time as the relevant working areas for example chassis, brakes, engine or also the Video-scope program. These give the visitors an overview of all solutions offered by us as well as concepts.



Impressive and practical the use of the KS special tools can be demonstrated on **work station areas** or even can be used by customers.

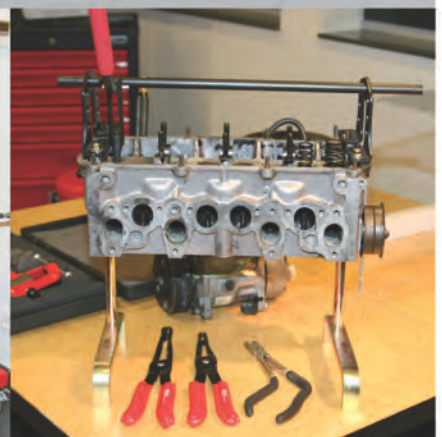

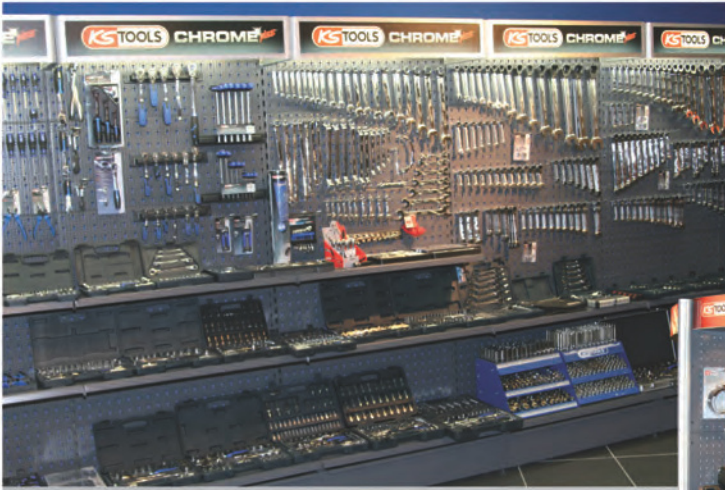

On **30 m display wall**
all essential product areas are found such as standard tools and special tools, e.g. the torque tool and puller program.



We are especially proud of our modern **conference room**

with modern multimedia technology. It has so much to offer as a place for interesting training and conferences.

Every workstation is equipped with a terminal computer, which enables interactive training and multimedia demonstrations.

Taken into account the permanently changing challenges in our marketplace the training and education of our employees is one of our major duties. In our own KS-academy many workshops such as for professional business administration, the latest computer applications take place regularly. The program within the academy has also included two foreign language courses with external instructors which enriches this offer of advanced education.

For our customers and trade partners there are regularly monthly product trainings for all product lines and novelties as well. We look forward to welcome you in our premises.

Simply ask about our training plan.

For larger groups or single firm, we are able to offer tailor made and

individually designed product trainings combined with the use of our meeting facilities.



SERVICE VAN



We optimize your KS Tools - shop presentation! Our very own team will arrange an appointment to visit our trade partners to set up and decorate display boards, show cases etc. on the spot. On board of the fully equipped service mobile we carry all accessories and items to attractively present KS Tools products.

We have a large catalogue with our presentation systems, whether on small or large area we offer tailor made solution to you in order to increase the attraction of the presentation of our range of tools and machines. Your local area manager will be able to provide more details on the available possibilities.



Twelve highly qualified technicians are selected to visit **together with our excellent trade partners**

automotive repair shops. By this way we can not only clarify particular special applications and needs of our customers, but we can also carry out technical training on the various tools available at the same time.

Our mobile information fleet represents a selective cross section over all product lines with a main focus on the automotive sector, since these products require an intensive amount of explanation and demonstration and most of all: the users can try out the products themselves.

In case you are interested in a product demonstration, talk to us! Our regional representatives will more than welcome your request and will assist you.

Needless to mention that this service and opportunity is for free. Arrange an appointment with your regional representative and discover the world of tools and get convinced of this opportunity and the benefits.



THE FLEET OF INFORMATION VANS



Innovation is our mission!

12 demo vehicles and demo trucks come along our fleet. We are proud to present three 12.5 t event vehicles!

Equipped with 10 fully configured tool trolleys, we present on more than 54 m² display space the complete program of special tools for the mechanic. These trucks are extremely desired and supporting as our "Show of Tools" on wheels - unique in Europe.



KS TOOLS RACING

Innovation is
our mission!



Official
tool supplier to the
2012 + 2013 +

KS TOOLS PREMI

RELIABLE UNDER EXTREME



PARTNERSHIPS



Innovation is our mission!

KS Tools tools and repair systems can be introduced well in the world of rally sport. Numerous teams use our tools and equipment at events such as the "U.A.E. Desert Challenge" in Dubai or the world famous, legendary "DAKAR" rally. In the hardest motorsport in the world not only the speed of the vehicle and the crew counts to the criteria decisive for success, but above all the reliability of the material and the service equipment. We pose ourselves this challenge with pride. The "2drive Racing" team and the "X-Raid" team only use tools and equipment from KS Tools.

The ultimate endurance test!

exclusive
Dakar rally winners
+ 2014 + 2015

UM TOOLS

OPERATING CONDITIONS!



SERVICE CENTRE



*Innovation is
our mission!*

The KS SERVICE CENTRE is your direct contact and co-ordinator for all kind of service related to all our products.

We guarantee short reaction times and economical repairs in our specially established SERVICE CENTRE.

The KS Service Centre offers the following benefits

- Repair, adjustment, calibration and certification of KS Tools torque wrenches
- Monitoring service for testing tools for torque wrenches
- Our economical calibration service and torque testing laboratory provides certificates in accordance to all existing norms and standards as per DIN EN ISO 9000.



PREMIUM SERVICE

When it comes to maintenance or replacement part procurement or even repairs we are always available with advice and support. Our service employees are also available after purchase with our all-round premium service.



Further more we offer examination and economical repairs for our entire catalogue range.

QUALITY / GUARANTEE



Management System
ISO 9001:2008

www.tuv.com
ID 9105033220

Quality guaranteed through systematic quality assurance in accordance to DIN EN ISO 9001:2008

Our company is certified in accordance to ISO 9001:2008 and is subject to permanent monitoring by TÜV Rheinland GmbH. Our constant drive for innovative products and the increased quality awareness of our customers demand for continuous improvement of the product quality and productivity.

All employees of our company are committed to exercise the maximum possible diligence and permanent controls and checks at all levels in order to ensure the highest level of quality.

This means for our customers:

Guaranteed quality and controlled safety at the highest stage!

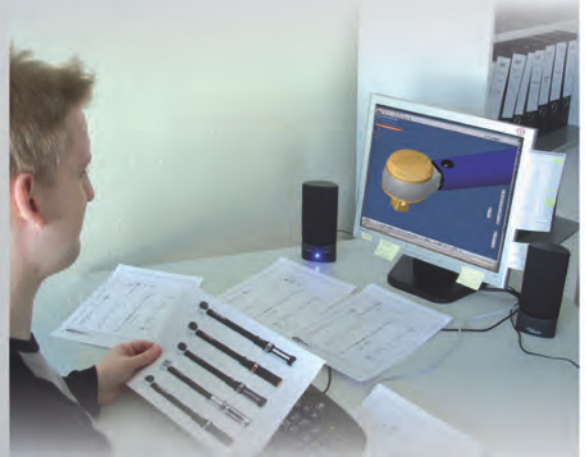

KS Tools equipment is manufactured to the highest quality standards and from the very best material.

However if any of our products show a lack of quality due to material failure or manufacturing fault we guarantee free replacement.

That we guarantee!

KS TOOLS ONLINE



CLIP FINDER.COM

1:1

www.clipfinder.com

ALFA ROMEO | BMW | CHRYSLER | FIAT | FORD | HYUNDAI | JAGUAR | LANCIA | LAND ROVER | MAZDA | MERCEDES-BENZ
 MITSUBISHI | PEUGEOT | ROVER | CITROËN | RENAULT | SAAB | VAUXHALL | OPEL | VOLKSWAGEN AUDI GROUP | VOLVO

Toolfinder

www.motoreinstellwerkzeuge.de

www.outilsdecalagemoteur.fr

ENGINE TIMING TOOLS
 MOTOR EINSTELLWERKZEUGE
 OUTILS DE CALAGE MOTEUR

www.timingtools.de

TOOL CHANNEL

www.toolchannel.com

KS TOOLS APP

kstools.com

www.ks-portal.com

Offizieller Exklusiv-Werkzeugausrüster des Dakar-Siegers 2012/2013/2014

KS TOOLS

Official exclusive tool supplier to the winner of the Dakar Rally 2012/2013/2014

www.kstools.com

Loyalty to specialised trade

Expert advice

Sales support

CATALOGUE LAYOUT



Significant product photographs



Coloured index for quick navigation



Clear specification of the set contents



Extensive description of the product specifications

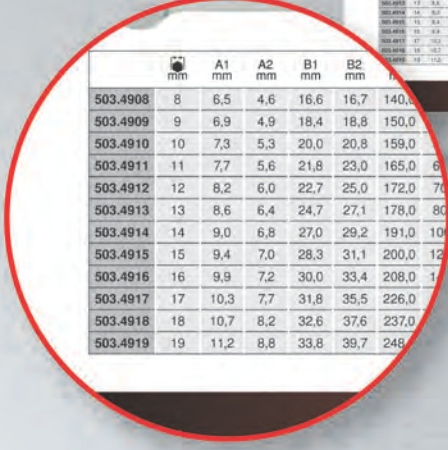

Tabular clear view of the technical features



Technical drawing with all measurement dimensions

THE HAND TOOLS CATALOGUE



*Innovation is
our mission!*



**22 SECTIONS
500 PRODUCT GROUPS
650 PAGES
12,000 ARTICLES**



www.kstools.com

1. Bodywork and interior		Page
1.1	Vehicle lighting and bumpers	36
1.2	Plastic repair	36 - 37
1.3	Parking sensor tools	37 - 38
1.4	Trim	38
1.5	Door hinges and handles	38 - 39
1.6	Door opener	39 - 40
1.7	Exterior mirror	40
1.8	Lever and separating tools	40 - 43
1.9	Body boring tools	43 - 45
1.10	Coolant	45
1.11	Spot weld drills	45 - 46
1.12	Bending and pulling tools	47 - 51
1.13	Hammering tools	51 - 59
1.14	Wing brake pipe flaring	59
1.15	Bodywork files	60
1.16	Hole, setting, and seam pliers	60 - 61
1.17	Sheet metal nibbler and snips	61 - 64
1.18	Panel saws	64
1.19	Locking pliers	64 - 69
1.20	Blind rivet tools	69 - 71
1.21	Welding	72 - 74
1.22	Surface treatment	74 - 79
1.23	Internal cleaning	80
1.24	Wire brushes	80 - 82
1.25	Steering wheel and fitting	82 - 83
1.26	Airbag	83 - 85
1.27	Locking cylinder	85
1.28	Radio and navigation system	86 - 88
1.29	Clip, rivet and extraction tools	88 - 90
1.30	Fastening clips for Alfa Romeo	91
1.31	Fastening clips for Audi	91 - 94
1.32	Fastening clips for Bmw	94 - 96
1.33	Fastening clips for Chrysler	96 - 99
1.34	Fastening clips for Citroën / Peugeot	99 - 101
1.35	Fastening clips for Fiat	101 - 102
1.36	Fastening clips for Ford	102 - 106
1.37	Fastening clips for Honda	106 - 109
1.38	Fastening clips for Isuzu	109
1.39	Fastening clips for Kia	109
1.40	Fastening clips for Mazda	110 - 112
1.41	Fastening clips for Mercedes	112 - 114
1.42	Fastening clips for Mitsubishi	114 - 115
1.43	Fastening clips for Nissan	116 - 118
1.44	Fastening clips for Opel	119 - 122
1.45	Fastening clips for Renault	122 - 123
1.46	Fastening clips for Seat	123 - 124
1.47	Fastening clips for Škoda	124
1.48	Fastening clips for Subaru	124
1.49	Fastening clips for Toyota / Lexus	124 - 128
1.50	Fastening clips for Volkswagen	128 - 132
1.51	Fastening clips for Volvo	132 - 133
1.52	Fastening clips - Cable harnesses	133 - 135

1.53	Fastening clips - Plastic rivets	135 - 136
1.54	Fastening clips - Quick-release fastener	136 - 137
1.55	Fastening clips - Push-in rivets	137 - 138
1.56	Fastening clips - Plastic nuts	139 - 140
1.57	Fastening clips - Screw-in rivets	140 - 142
1.58	Fastening clip sets	142 - 147
1.59	Interior trim and liner	148 - 153
1.60	Storage compartments	153 - 155
1.61	General tools	155 - 157
2. Engine - Engine cooling system		Page
2.1	Water pump test	160
2.2	Water pump tool	160
2.3	Cooling system vacuum filling device	160 - 161
2.4	Cooling system cone test adapter	161
2.5	Pressure test pumps	161
2.6	Cooler adapter	162 - 164
2.7	Cooling system diagnosis system set	164
2.8	Cylinder head leak tester	165
2.9	Thermal switch socket	165
2.10	Locking screw turner	165
2.11	Counter hold tool	166 - 167
2.12	Frost protection and coolant water tester	167 - 168
2.13	Temperature measuring device	168
2.14	Hose clamp tool	168 - 172
2.15	Hose clamp tools	172 - 173
2.16	Drip pans	173
2.17	Measuring beaker, jug and funnel	174
2.18	Transfer pumps	174 - 175
3. Engine - Hose clamp pliers		Page
3.1	Screw hose clamps	178
3.2	Spring strip hose clamps	178 - 181
3.3	Click and cobra hose clamps	181 - 182
3.4	Earless hose clamps	182
3.5	One ear hose clamps	182
3.6	Tension bands	182 - 183
3.7	Spring wire hose clamps	183
3.8	Fuel pipe clamp pliers	183
3.9	Hose clamp pliers sets	183 - 184
3.10	Hose assembly and removal tools	184
4. Engine - Fuel system		Page
4.1	Hose clamp tool	188 - 192
4.2	Hose pinch tool	192 - 193
4.3	Fuel pipe clamp pliers	193 - 194
4.4	Pipe coupling unlocking tool	194 - 195
4.5	Pipe wrench	195 - 196
4.6	Injector nozzle tool	196 - 199
4.7	Fuel filler tool	199 - 200
4.8	Tank sender wrench	200 - 201
4.9	Test device	201 - 203
4.10	Transfer pumps	203 - 204
4.11	Filling device and air vent device	204
5. Engine - Cylinder head / engine block		Page
5.1	Tools for engine block screws	208 - 209

5.2	Tools for cylinder block screws	209 - 212
5.3	Vibration damper tools	213
5.4	Service stands and parts stations	213
5.5	Slide rail bolts extraction tools	213
5.6	Guide sleeves internal extractor	213
5.7	Extraction tool and spiral profile sockets	213 - 216
5.8	Nut splitter	216 - 217
5.9	Thread boring tool and bore jigs	217
5.10	Crank shaft facing tools	218
5.11	Valve gauges	218
5.12	Valve pneumatic adapter	218
5.13	Valve retainer and valve spring tensioner	218 - 220
5.14	Valve shaft sealing tools	220 - 221
5.15	Gasket scraper	221 - 222
5.16	Sealing ring tools	222 - 223
5.17	Valve seat cutter	224
5.18	Valve cutter	224
5.19	Valve wedge assembly	224
5.20	Valve adjustment tools	224 - 225
5.21	Piston ring tools	225
5.22	Cylinder liner tools	225
5.23	Cylinder hon devices	226
5.24	Test and measuring tools	226 - 228
6. Engine - Turbocharger		Page
6.1	Hose clamp tool	232 - 235
6.2	Gasket scraper	235
6.3	Sealing ring hook tools	235 - 236
6.4	Special spanner and adapter	236
6.5	Vacuum testing tools	236
6.6	Pressure testing tools	237 - 238
6.7	Testing accessories	238
7. Engine - Fuel injection system		Page
7.1	Fuel injector rail wrench	242 - 245
7.2	Pre-combustion chamber socket wrench	245 - 246
7.3	Inspection and test tools	246 - 247
7.4	Pneumatic adapter for glow plug bores	247
7.5	Injector removal tools	248 - 249
7.6	Injector sealing ring extractor	249
7.7	Injector and injector seat cleaning	250 - 251
7.8	Injector shaft cleaning	251 - 252
7.9	Injector pump wrench	252
7.10	Pump wheel extractor	252
7.11	Lockring driver and adjustment tools	252 - 253
7.12	Injector pump adjusting tools	253 - 254
8. Engine - Spark plugs		Page
8.1	Spark plug connector puller	258
8.2	Ignition coil puller	258 - 259
8.3	Spark plug connector pliers	259 - 260
8.4	Standard nut sockets for spark plugs	260 - 262
8.5	Spark plug screwing aid	262
8.6	Torque tools	262
8.7	Reamer for cleaning	263
8.8	Spark plug thread repair	263

8.9	Spark plug thread cutting tools	263 - 264
8.10	Contact cleaning	264
8.11	Sensor and thread gauges	265
8.12	Test device	265
9. Engine - Glow plugs		Page
9.1	Glow plug connector pliers	268
9.2	Standard nut sockets for glow plugs	268 - 269
9.3	Glow plug screwing aid	269
9.4	Torque tools	270
9.5	Ratchet ring spanner	270
9.6	Electrode head extraction tool	270
9.7	Glow plug extractor tools	270 - 271
9.8	Reamer for cleaning	271 - 272
9.9	Glow plug drill out tools	272 - 273
9.10	Glow plug thread cutting tool	273 - 274
9.11	Glow plug thread repair	274 - 276
9.12	Thread gauges	276
9.13	Test device	276
10. Engine - Auxiliary drive belt / alternator		Page
10.1	Tension pulley wrench v/v ribbed belts	280 - 281
10.2	Elastic belt tool	281
10.3	Counter hold tool	281 - 282
10.4	Visco fan tool	283 - 284
10.5	Slogging spanner	284
10.6	Alternator wrench	284
10.7	Free-running belt disc tool	284 - 286
10.8	Belt tension checker	286
10.9	Pulling tool	286 - 287
10.10	Stethoscope	287
11. Engine timing tools		Page
11.1	Alfa Romeo	291 - 293
11.2	Audi	293 - 302
11.3	BMW	303 - 307
11.4	Chrysler	307
11.5	Citroën	308 - 310
11.6	Fiat	311 - 315
11.7	Ford	316 - 320
11.8	GM	320 - 321
11.9	Honda	321
11.10	Hyundai	321
11.11	Isuzu	321 - 322
11.12	Iveco	322 - 323
11.13	Jaguar	323 - 324
11.14	Kia	324
11.15	Lancia	324 - 325
11.16	Land Rover	325 - 327
11.17	Mazda	327 - 328
11.18	Mercedes	328
11.19	MINI	328 - 329
11.20	Mitsubishi	329
11.21	Nissan	330 - 331
11.22	Opel	331 - 336
11.23	Peugeot	336 - 339

11.24	PSA	339 - 342
11.25	Renault	343 - 346
11.26	Rover	346 - 347
11.27	Saab	347 - 349
11.28	Seat & Škoda	350 - 354
11.29	Volkswagen	355 - 363
11.30	Volvo	364 - 365
11.31	Universal	365 - 369
11.32	Belt tension checker	369
12. Exhaust system / catalysers		Page
12.1	Tools for exhaust sensors	372 - 373
12.2	Thread repair	373 - 374
12.3	Pliers for exhaust systems	374
12.4	Exhaust pipe separating and cutting tools	375 - 377
12.5	Exhaust pipe hook tools	377
12.6	Special tool EGR / pressure sensor	377
12.7	Exhaust pressure detector	377
13. Air conditioning		Page
13.1	Wire connector unlocking device	380
13.2	Thermometer	381
13.3	UV leak detection lamps	381
13.4	Leak detection devices	382
13.5	Air conditioning system tools	382 - 383
13.6	Sealing rings	383
13.7	Sealing ring hook tools	383 - 384
13.8	Cleaning devices	384
14. Battery service		Page
14.1	Pole terminal extractor	388
14.2	Pole terminal cleaning	388
14.3	Battery plug tools	389
14.4	Battery cell filling	389 - 390
14.5	Battery carrying handles	390
14.6	Vehicle power supply voltage retainer	390
14.7	Battery tester	390 - 393
14.8	Surge protection	393
14.9	Battery chargers	393 - 394
14.10	Jump leads	394
14.11	Booster	395
14.12	Accessories for rechargeable-booster packs	395
15. Electrical / electronic tools		Page
15.1	Relay tester	398
15.2	Key tester	398
15.3	Voltage testers	398 - 399
15.4	Digital ampere meter	399 - 400
15.5	Circuit breakers	400
15.6	Trailer socket tester	400
15.7	Cigarette lighter socket tester	400
15.8	Multimeter	401
15.9	Multimeter accessories	402 - 404
15.10	Disassembly and assembly tools	404
15.11	Cleaning tools	404
15.12	Housing types	405 - 408
15.13	Release principle	409 - 411

15.14	Universal unlocking tools	412
15.15	Unlocking tools for receptacles/fl t plugs	412 - 416
15.16	Unlocking tools for circular socket/round plugs	416 - 419
15.17	Unlocking tools for housing	419
15.18	Unlocking tool sets	419 - 420
15.19	Stripping tools	421 - 422
15.20	Cutting tools	422 - 423
15.21	Crimping pliers	423 - 425
15.22	Din and standard parts	425 - 426
15.23	Electrical insulating tape	426
15.24	Soldering tools	427
16. Hybrid / high-voltage tools		Page
16.1	Industrial safety	430 - 431
16.2	1/4" Program	432
16.3	3/8" Program	433 - 435
16.4	1/2" Program	435 - 437
16.5	Spanners	437 - 438
16.6	Pliers	438 - 442
16.7	Plastic pliers / clamps	442 - 443
16.8	Crimping tools	443 - 444
16.9	Screwdrivers	444
16.10	Key wrenches	444 - 445
16.11	Cable cutting	445 - 447
16.12	Electrician's knives	447 - 448
16.13	Sawing	449
16.14	Brushes	449
16.15	Hammer	449
16.16	Boots and insulation	449 - 450
16.17	Tweezers	450
16.18	Inspection mirrors	450
16.19	Led lamp	450
16.20	Insulated tool sets	450 - 451
17. Gearbox		Page
17.1	Pin wrench	454
17.2	Box spanners	454 - 455
17.3	Securing bolts	455
17.4	Pliers	456
17.5	Pry bar	456 - 457
17.6	Support devices	457 - 458
17.7	Hook wrench	458 - 459
17.8	Pullers	459 - 461
17.9	Prisms	461
17.10	Oil service tools	461 - 464
17.11	Hand pumps	464
17.12	Filling	464 - 465
17.13	Drip pans	465 - 466
17.14	Old oil fall arresters	466
18. Gearbox		Page
18.1	Centring tools	472 - 473
18.2	SAC clutch tools	473 - 475
18.3	DSG clutch tools	476
18.4	Dual mass flywhe l degree test tools	476 - 477
18.5	General clutch tools	477 - 478

19. Springs / shock absorbers		Page
19.1	Release tools	482 - 485
19.2	Splay tools	485
19.3	Support devices	486
19.4	Camber adjustment tools	486 - 487
19.5	Spring feet bracket	487
19.6	Mc Pherson spring compressor	487 - 489
19.7	Internal spring compressor	490
19.8	Stationary spring compressor	490
20. Steering and steering geometry		Page
20.1	Lever / pry bars	494
20.2	Wishbone disassembly	494 - 495
20.3	Axle play test tool	495
20.4	Universal pivot pin ejector	495 - 496
20.5	Universal ball joint ejector with lever	496 - 497
20.6	Ball pin puller Vibro Impact	497 - 498
20.7	Clamp screws ejector	498
20.8	Splay tools	498 - 499
20.9	Steering wheel puller	499
20.10	Steering wheel installation balance	499
20.11	Press and pull sleeve set	500 - 502
20.12	Universal press frame system PP I	502
20.13	Hydraulic support system PP I	502
20.14	Hydraulic support universal	502 - 503
20.15	C-frame system PP I	503
20.16	Ball joint system PP I	503 - 504
20.17	Hydraulic support system PP II	504 - 506
20.18	Adaptor	506
20.19	Press tool system PP II	506
20.20	Press stand system PP II	506
20.21	Ball joint system PP II	506 - 508
20.22	Ball joint system PP III	508
20.23	Wrenches for ball joint assembly	508 - 509
20.24	Vibro Impact	509 - 510
20.25	Separation and assembly fork	510
20.26	Track rod tools	510 - 512
20.27	Tracking adjustment tools	512 - 513
20.28	Camber adjustment tools	513
20.29	Hose clamp tool	513 - 515
21. Axle		Page
21.1	Wheel bearing system PP I	518
21.2	Hydraulic system PP II	518 - 520
21.3	Adapter	520
21.4	Universal spindle drive	520
21.5	Wheel bearing assembly system PP II	521
21.6	Wheel hub disassembly system PP II	521 - 524
21.7	Wheel hub tool system PP III	524 - 525
21.8	ABS rotor tool	525
21.9	Wheel hub tool system PP I	525 - 526
21.10	Wheel hub tool system PP II	526
21.11	Wheel hub tool system PP III	526 - 527
21.12	Bearing ring tool	527
21.13	Pliers for securing rings	527 - 529

21.14	Prop shaft tool	529 - 530
21.15	Axle boots	531
21.16	Hose clamp tool	531 - 533
21.17	Press and pull sleeve set	534 - 536
21.18	Universal press frame system PP I	536
21.19	Hydraulic support system PP I	536
21.20	Hydraulic support universal	536 - 537
21.21	C-frame system PP I	537
21.22	Hydraulic system PP II	537 - 539
21.23	Adaptor	539
21.24	Press stand system PP II	539
21.25	Silent bearing tool system PP II	540 - 542
21.26	Silent bearing tool system PP III	542 - 544
21.27	Camber adjustment tools	545
21.28	Tracking adjustment tools	545 - 546
21.29	Lever / pry bars	546 - 547
21.30	Axle play test tool	547
21.31	Socket set for chassis bolting	547 - 548
21.32	Vibro impact	548 - 549
21.33	Extractor	549
21.34	Press underlays	549

22. Auto glass

Page

22.1	Wiper arm disassembly	552 - 554
22.2	Washer nozzle tool and magnet lifter	554 - 555
22.3	Dashboard panel	556
22.4	Interior and wing mirror	556 - 557
22.5	Sensors	557 - 558
22.6	Plastic wedges	558 - 560
22.7	Transport and storage	560 - 561
22.8	Platform	561
22.9	Removal tool - non glued car windscreens	561 - 562
22.10	Panel bag	562
22.11	Removal tool - glued car windscreens	563 - 566
22.12	Suction pads	567 - 568
22.13	Glass repair	568 - 569
22.14	Scrapers	569 - 570
22.15	Nozzle cartridge pliers	570
22.16	Hand pistol cartridges	571
22.17	Cordless cartridge gun	571
22.18	Pressurised air pistol cartridges	572
22.19	Assembly spatula	572
22.20	Aid	572

23. Brake service

Page

23.1	Brake piston reset tool	576 - 579
23.2	Brake sensor cleaning tool	579 - 580
23.3	Brake calliper tool	580 - 582
23.4	Cotter pin drives	582 - 584
23.5	Brake spring tool	584 - 585
23.6	Brake pipe tester	585
23.7	Brake spring pliers	585 - 586
23.8	Brake pedal locking device	586
23.9	Brake calliper cleaning	586 - 587
23.10	Wheel hub cleaning	587 - 589

23.11	Brake disc scraper	589
23.12	Assembly sleeves	590
23.13	Pipe stopper	590
23.14	Brake pipe cutter	590
23.15	Brake pipe deburrer	590
23.16	Brake pipe bending tool	591
23.17	Brake pipe flaring tool	591 - 592
23.18	Brake calliper repair tool	592
23.19	Brake fluid tester	592
23.20	Brake bleed wrenches	592 - 594
23.21	Brake bleeder	594 - 596
23.22	Brake maintenance tool	596 - 597
23.23	Brake measuring tool	597 - 599

24. Oil service

Page

24.1	Oil drain plug release tool	602 - 604
24.2	Oil drain plugs & seal rings	605 - 622
24.3	Oil sump tool	623
24.4	Transmission oil coolant tool	623
24.5	Oil drain plug thread repairer	623 - 625
24.6	Oil filler tension wrench	625 - 627
24.7	Special oil filler wrench	627
24.8	Oil filler cap wrench	628 - 635
24.9	Oil filler cap wrench set	635 - 637
24.10	Oil filler cutter	637
24.11	Oil dip stick	637
24.12	Oil filling and emptying pump	637 - 638
24.13	Oil filling container	639 - 641
24.14	Oil collection pan	641 - 642

25. Wheel / tyre fitting

Page

25.1	Hub cap tools	646
25.2	Magnetic holders	646
25.3	Tyre storage	646
25.4	Torsion rods	647 - 649
25.5	Special boring tools	649
25.6	Wheel bolting socket wrench	649 - 652
25.7	Wheel nut wrench	652 - 653
25.8	Manual release tools	653
25.9	Torque wrenches	653 - 654
25.10	Tyre service hammers	654 - 655
25.11	Wheel hub cleaning	655 - 657
25.12	Tyre pressure control system sets	657 - 663
25.13	Thread repair	663 - 664
25.14	Profile depth measurer	664
25.15	Wheel filling gauge	664 - 665
25.16	Mounting lever	665
25.17	Bead hold-down device	665
25.18	Valve boring tools	665 - 666
25.19	Valve lift	666
25.20	Tyre service pliers	666 - 667
25.21	Adhesive weight remover	667
25.22	Tyre fitting grease	667 - 668
25.23	Tyre repair	668 - 669
25.24	Wedges	670

25.25	Lift technology	670 - 672
25.26	Tyre transport	672
26. General workshop requirements		Page
26.1	Vices	676 - 677
26.2	Service trolleys	677
26.3	Platform trolley	677
26.4	Platform	678
26.5	Supports	678
26.6	Paint requirements	679
26.7	Painting stands	679 - 680
26.8	Pallet cage trolley	680
26.9	Transport trolley	680 - 681
26.10	Key chain	682
26.11	Document pockets	682
26.12	Seat and vehicle covers	682 - 684
26.13	Knee and lie down mats	684 - 685
26.14	Creepers / stools	685
26.15	Vehicle trolleys	685 - 686
26.16	Wheel chocks	686
26.17	Axle stands and ramps	686 - 687
26.18	Lift technology	687 - 689
26.19	Engine stand	690
26.20	Workshop winches	690
26.21	Engine and transmission engines	690 - 691
26.22	Used oil run off device	691 - 692
26.23	Workshop equipment	692
26.24	Transmission oil filling device	692 - 693
26.25	Oiler	693 - 694
26.26	Grease gun	694 - 695
26.27	Suction and filling hand pumps	695 - 697
26.28	Pressure pump vaporiser	697
26.29	Measuring beaker, jug and funnel	697 - 698
26.30	Paper stands	698
26.31	Magnetic holders	698
26.32	Optical test device	699
26.33	Barrel pump	699
26.34	Air blow out tools	699 - 700
26.35	Thermometer	700 - 701
26.36	Air purifier	701
26.37	Heat guns	701

BODYWORK AND INTERIOR 1

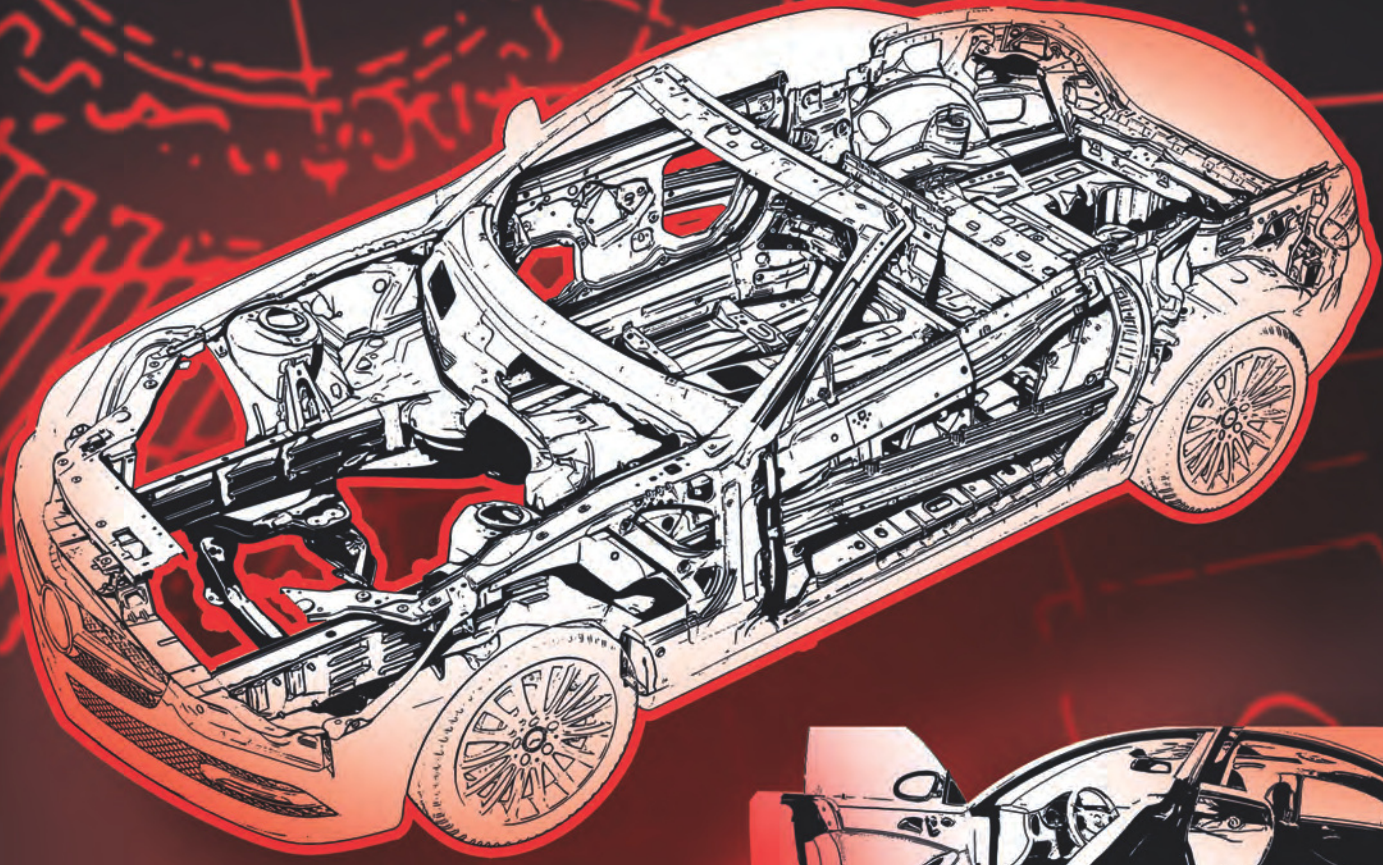

Innovation is
our mission!



	PAGE	
VEHICLE LIGHTING AND BUMPERS	36	2
PLASTIC REPAIR	36 - 37	
PARKING SENSOR TOOLS	37 - 38	3
TRIM	38	
DOOR HINGES AND HANDLES	38 - 39	4
DOOR OPENER	39 - 40	
EXTERIOR MIRROR	40	
LEVER AND SEPARATING TOOLS	40 - 42	5
BODY BORING TOOLS	43 - 45	
COOLANT	45	6
SPOT WELD DRILLS	45 - 46	
BENDING AND PULLING TOOLS	47 - 51	
HAMMERING TOOLS	51 - 59	7
WING BRAKE PIPE FLARING	59	
BODYWORK FILES	60	
HOLE, SETTING, AND SEAM PLIERS	60 - 61	8
SHEET METAL NIBBLER AND SNIPS	61 - 64	
PANEL SAWS	64	9
LOCKING PLIERS	64 - 69	
BLIND RIVET TOOLS	69 - 71	
WELDING	72 - 74	10
SURFACE TREATMENT	74 - 79	
INTERNAL CLEANING	80	11
WIRE BRUSHES	80 - 82	
STEERING WHEEL AND FITTING	82 - 83	
AIRBAG	83 - 85	12
LOCKING CYLINDER	85	
RADIO AND NAVIGATION SYSTEM	86 - 88	13
CLIP, RIVET AND EXTRACTION TOOLS	88 - 90	
FASTENING CLIPS FOR ALFA ROMEO	91	
FASTENING CLIPS FOR AUDI	91 - 94	14
FASTENING CLIPS FOR BMW	94 - 96	
FASTENING CLIPS FOR CHRYSLER	96 - 99	15
FASTENING CLIPS FOR CITROËN/PEUGEOT	99 - 101	
FASTENING CLIPS FOR FIAT	101 - 102	
FASTENING CLIPS FOR FORD	102 - 106	16
FASTENING CLIPS FOR HONDA	106 - 109	
FASTENING CLIPS FOR ISUZU	109	17
FASTENING CLIPS FOR KIA	109	
FASTENING CLIPS FOR MAZDA	110 - 112	
FASTENING CLIPS FOR MERCEDES	112 - 114	18
FASTENING CLIPS FOR MITSUBISHI	114 - 115	
FASTENING CLIPS FOR NISSAN	116 - 118	
FASTENING CLIPS FOR OPEL	119 - 122	19
FASTENING CLIPS FOR RENAULT	122 - 123	
FASTENING CLIPS FOR SEAT	123 - 124	20
FASTENING CLIPS FOR ŠKODA	124	
FASTENING CLIPS FOR SUBARU	124	
FASTENING CLIPS FOR TOYOTA/LEXUS	124 - 128	21
FASTENING CLIPS FOR VOLKSWAGEN	128 - 132	
FASTENING CLIPS FOR VOLVO	132 - 133	22
FASTENING CLIPS - CABLE HARNESSSES	133 - 135	
FASTENING CLIPS - PLASTIC RIVETS	135 - 136	
FASTENING CLIPS - QUICK-RELEASE FASTENER	136 - 137	23
FASTENING CLIPS - PUSH-IN RIVETS	137 - 138	
FASTENING CLIPS - PLASTIC NUTS	139 - 140	24
FASTENING CLIPS - SCREW-IN RIVETS	140 - 142	
FASTENING CLIP SETS	142 - 147	
INTERIOR TRIM AND LINER	148 - 153	25
STORAGE COMPARTMENTS	153 - 155	
GENERAL TOOLS	155 - 157	26

VEHICLE LIGHTING AND BUMPERS

ERGOTORQUE^{plus} T-handle TX key wrench, long

- Extra-long design
- With two component handle
- Continuous hardened
- Tip burnished
- Chrome plated and mirror polished
- Special steel

Application range: Fittings, engine, bumper, headlamps, fuse boxes, etc.

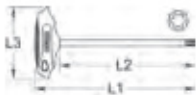
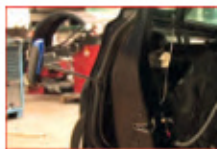

	⚙️	L1 mm	L2 mm	L3 mm	👤
158.8051	T10	403.0	373.0	80.0	30
158.8052	T15	403.0	373.0	80.0	30
158.8053	T20	403.0	373.0	100.0	40
158.8054	T25	408.0	373.0	100.0	40
158.8055	T27	408.0	373.0	100.0	40
158.8056	T30	408.0	373.0	100.0	45

ERGOTORQUE^{plus} T-handle TX key wrench set

- Extra-long design
- With two component handle
- Continuous hardened
- Tip burnished
- Chrome plated and mirror polished
- Special steel

Application range: Fittings, engine, bumper, headlamps, fuse boxes, etc.

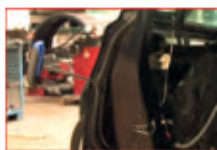

	👤
158.8050 6 pcs T10 - T15 - T20 - T25 - T27 - T30	375

Headlamp adjusting key Audi

- Ideal for the adjustment of the headlamps
- Extra-long design
- with T-handle
- With suspension hole
- Continuous hardened
- Multi-tooth head with centring pin, bronzed
- Chrome plated
- Chrome vanadium

Application range: Audi A4 (8K), A6 (4G), A5 (8T)



	Total length mm	👤
150.8105	345.0	170

ERGOTORQUE[®] scr ewdriver for phillips screws PH

- DIN/ISO 8764
- 1 piece handle
- Optimal power transmission
- With suspension hole
- Hardened blade
- Chrome finish with burnished tips
- Blade made of chrome vanadium

Application range: Headlamp adjustment screwdriver for Volkswagen Golf 3, Vento, etc.

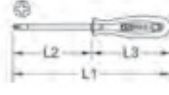

		L1 mm	L2 mm	L3 mm	👤
911.1188	PH 2	350.0	250.0	100.0	140

Incandescent bulbs pliers

- With protecting foam material
- For the removal and replacement of incandescent bulbs
- With internal spring
- Plier jaws with foam protection material
- Suited for glass socket lamps of 4,0 mm until 6,0 mm
- Special plastic

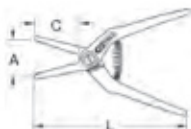

	A mm	C mm	L mm	👤
115.1054	0-32	45.0	160.0	70

Hexagonal tube socket for bumper screw

- 6-point
- For actuating the bumper screw at the rear
- Internal square
- Extra-long design for actuating the screw via the threaded rod
- Allows controlled tightening of the screw to the torque specified by the manufacturer
- For manual operation
- Matt finish
- Chrome vanadium

Application range: Mercedes type 204, Audi A3 from 2004, A4 from 2001, A6 from 2005, TT from 2007



	👤	Ø mm	L mm	👤
917.1423	10,0	13,0	160,0	60

Brake lights removal fork set

- Suitable for disassembling the brake light from the tail gate
- Allows the correct unlocking of the retaining clamps
- High accuracy of fit
- For manual operation
- With PVC dipped handle
- Matt finish
- Chrome vanadium

Application range: Mercedes E Class (W210) T model



		L mm	👤
150.1691	4 pcs	135.0	260

PLASTIC REPAIR

Hot stapler set for plastic repair (cordless)

- Suitable for the repair of cracks or similar damage to plastic parts (from 1 mm thick)
- Also for plastics with a glass fibre content of max. 40%
- Battery operated, mains independent working
- Can also be used directly connected to the power supply
- Heating rod holder for different repair clamps with Ø 0.6 and 0.8 mm
- Heats the clamps with approx. 100-200°C
- Folding and with stand foot
- One battery charge lasts for approx. 150 repair clamps
- With 100 different clips per type
- Repair clamps are pressed into the break and give the plastic body its permanent stability back
- Includes operating, battery status and charge display
- Do not use on pure fibre-glass reinforced plastic or carbon

Application range: Bumpers, panels, covers, etc.



Technical data:

Input current:	DC 5 V 2 A
output current:	DC 3.7 V max. 8A
Battery charger:	100-240V / 50/60Hz
Charging time:	3-4 hours

	👤
150.1035 302 pcs Hot stapler set for plastic repair (cordless)	1.30

consists of:

150.1036	Plastic repair device		400	
150.1037	Power supply 12 V, 100-240 V, 50-60 Hz		93	
150.1051	Repair staple U-format Ø 0,6 mm		20	
150.1057	Repair staple U-format Ø 0,8 mm		20	
150.1052	Repair staple V-format Ø 0,6 mm		20	

Repair staples

- Suitable for repairing breaks on headlamps, bumpers, etc.
- The clamps are fused into the breaks
- Rust-proof
- Stainless steel



	Form	Ø mm	Content	
150.1051	U-form	0,6	100	20
150.1057	U-form	0,8	100	20

Repair staples

- Suitable for repairing breaks on headlamps, bumpers, etc.
- The clamps are fused into the breaks
- Rust-proof
- Stainless steel



	Form	Ø mm	Content	
150.1053	W shaped	0,6	100	20
150.1059	W shaped	0,8	100	20

Repair staples

- Suitable for repairing breaks on headlamps, bumpers, etc.
- The clamps are fused into the breaks
- Rust-proof
- Stainless steel



	Form	Ø mm	Content	
150.1052	V-form	0,6	100	20
150.1058	V-form	0,8	100	20

Repair staples

- Suitable for repairing breaks on headlamps, bumpers, etc.
- The clamps are fused into the breaks
- Rust-proof
- Stainless steel



	Form	Ø mm	Content	
150.1055	U-form	0,6	100	20
150.1061	U-form	0,8	100	20

Plastic soldering iron

- Ideal for small plastic repairs, e.g. cracks in the bumper, wings, engine panels, etc.
- Electrically-operated micro soldering device
- Includes holder



Capacity: 60 Watt
 Voltage range: 120, 220V / 230V / 240 V - 50Hz / 60Hz
 Working temperature: 0-400 °C
 Cable length: 1,35 m
 Heating blade: 15 x 26 mm

	Length mm	
960.1120	260,0	960

Reinforcement mat

- Suitable for plastic repairs
- Gives the plastic a secure hold
- For use alongside standard plastic soldering irons

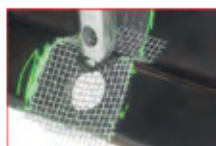

	Size mm	Content	
960.1126	150 x 110 mm	5	25

Plastic soldering iron set

- Ideal for small plastic repairs, e.g. cracks in the bumper, wings, engine panels, etc.
- Gas-operated micro soldering device
- With piezo ignition
- Adjustable gas supply
- With various repair sticks and reinforce mats
- Filled with standard lighter gas/ISO butane gas
- In durable plastic storage case



960.1115	33 pcs	Plastic soldering iron set	960

consists of:

960.1116	Plastic soldering iron		110
960.1117	Soldering iron add-on, Ø 9,0 mm		7
960.1118	Soldering iron add-on, Ø 12,0 mm		11
500.7111	Precision fl t-head screwdriver, 3 mm		20
201.2316	Brass wire spark plug wire brush, 2 rows		20
960.1119	Cleaning fil., round		6
960.1121	Reinforcement mats set, 3 pcs., 100 x 55 mm		9
960.1122	PE (Polyethylene) repair sticks set, 6 pcs., black		15
960.1123	PP (Polypropylene) repair sticks set, 6 pcs., black		15
960.1124	PS (Polystyrene) repair stick set, 6 pcs., black		15
960.1125	ABS repair stick set, 6 pcs., black		15

PARKING SENSOR TOOLS

Parking sensors pin wrench

- Suitable for assembly and removal of parking sensors, which are integrated into the front and rear bumpers
- Allows professional tightening to the prescribed torque
- Internal square in accordance with DIN 3121/ISO 1174
- High accuracy of fit
- For manual operation
- Matt finish
- Chrome vanadium

Application range: Mercedes S Class (W140) and E Class (W210)



	Length mm	
917.1424	106,0	360

Hole punch set for parking sensors (PDC)

- Ideal for punching holes into the bumper for parking sensors
- Allows the optimum diameter for parking sensors
- With various punches varying in size
- No damage to the paint when cutting out the holes
- Repainting is not necessary
- Parking sensors must be inserted to the exact millimetre due to their sensitivity
- Includes mandrels with which the parking sensors can be attached precisely to the bumper
- In durable plastic storage case



140.2540	14 pcs	Hole punch set for parking sensors (PDC)	2.36

consists of:

140.2542	Knob with ball bearing	360	
140.2543	Punch set with pin, 3 pcs., Ø 18.2 mm (VW, BMW)	140	
140.2546	Punch set with pin, 3 pcs., Ø 24.0 mm (Opel)	240	
140.2548	Punch set with pin, 3 pcs., Ø 26.0 mm (VW)	280	
140.2552	Punch set with pin, 3 pcs., Ø 32.0 mm (BMW)	380	
140.2554	Drill, 10 mm	40	

accessories:

140.2556	Punch set with pin, 3 pcs., Ø 18.0 mm (Skoda)	180	
140.2558	Punch set with pin, 3 pcs., Ø 26.7 mm (Skoda)	340	

TRIM
MASTER Induction Heat Gun Set

- For loosening rusted and seized connections
- For loosening "insoluble" glued connections
- Induction principle
- Pinpoint heating in seconds
- Heating of components to max. 780°C (red hot)

Application range: Screws, nuts and bolts, exhaust clamps and pipes, lambda probes, running gear, stuck bearings, ball joints, steering (e.g. tracking adjustment screws), chemically micro-encapsulated threaded connections (bonded), warming of bearing housings during dismantling and assembly

Technical data:

Capacity: 1500 Watt

500.8415	12 pcs. MASTER Induction Heat Gun Set	3.88	

consists of:

500.8420-1	Induction heat gun	1830	
500.8431	Induction coils 15mm, standard	48	
500.8432	Induction coils 19mm, standard	53	
500.8433	Induction coils 22mm, standard	54	
500.8434	Induction coils 26mm, standard	54	
500.8435	Induction coils 32mm, standard	64	
500.8436	Induction coils 38mm, standard	70	
500.8423	Induction coils 22mm, extra long	760	
500.8424	Induction coils 26mm, extra long	810	
500.8450	Induction coil, cable, fully flexible, standard	62	
500.8445	Induction coil, semi-rigid, deformable, universal	42	
500.8440	Induction pad	175	

Induction pad

- Heat-resistant material
- Gentle on painted surfaces
- Flat and flexible surface
- Simple handling
- Can be used in conjunction with induction heating gun 500.8420-1

Application range: Removal of stickers, type plates, emblems, decorative strips, self-adhesive films and small rims on painted surfaces

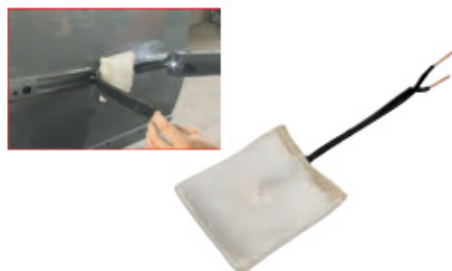

	mm	Length mm	
500.8440	100 x 100	260.0	175

Trim and window mounting set

- For fixing and holding trims, emblems and windscreen mountings
- Wide side can also be used as a scraper or lever
- With suction cup
- Quick and easy mounting
- Simple to remove by lifting the tab
- Dosing of the contact pressure with the wing nut



		Length mm	Suction cup Ø mm	
140.1020	6 pcs.	180.0	85.0	250

consists of:

	X		
140.1021	6	Suction holder for trim mounting, Ø 85mm	40

DOOR HINGES AND HANDLES
Door lock screwdriver

- Spline (XZN[®])
- Suitable for the assembly and disassembly of the door lock screws
- Also suitable for the external door handle
- 1 piece handle
- Blade made of chrome vanadium

Application range: Audi TT, Volkswagen Golf 4, Passat B5, Lupo, New Beetle, Bora, Seat, Škoda, etc.

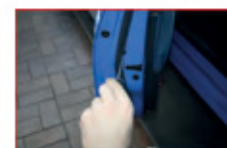

		L1 mm	L2 mm	
911.1117	M4	215.0	125.0	50

ERGOTORQUEplus[®] T-handle TX key wrench, long

- Extra-long design
- With two component handle
- Continuous hardened
- Tip burnished
- Chrome plated and mirror polished
- Special steel

Application range: Fittings, engine, bumper, headlamps, fuse boxes, etc.

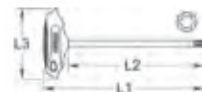

		L1 mm	L2 mm	L3 mm	
158.8051	T10	403.0	373.0	80.0	30
158.8052	T15	403.0	373.0	80.0	30
158.8053	T20	403.0	373.0	100.0	40
158.8054	T25	408.0	373.0	100.0	40
158.8055	T27	408.0	373.0	100.0	40
158.8056	T30	408.0	373.0	100.0	45

ERGOTORQUEplus[®] T-handle TX key wrench set

- Extra-long design
- With two component handle
- Continuous hardened
- Tip burnished
- Chrome plated and mirror polished
- Special steel

Application range: Fittings, engine, bumper, headlamps, fuse boxes, etc.

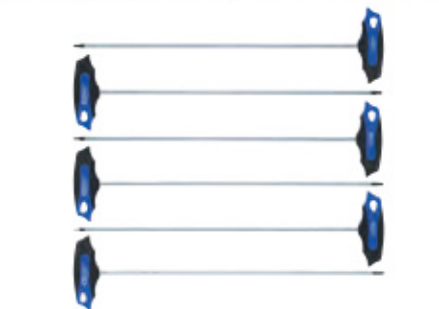

158.8050	6 pcs.	T10 - T15 - T20 - T25 - T27 - T30	375

Door hinge socket wrench

- TX-E
- Ideal for the assembly and disassembly of the deep-seated door hinge holding screws on the rear hinged door and sliding door
- Internal square in accordance with DIN 3121/ISO 1174
- Long design
- Phosphate
- Chrome molybdenum

Application range: Mercedes Sprinter from 2005 and Volkswagen LT



		L mm	
911.4451	E10	150.0	260

Central cable plug - grooved nut key

- 3-stage adjustable groove nut key
- For the disassembly and assembly of difficult to access central cable connectors on the A-pillar (installed in door frame)
- Easy to use
- Sturdy design

Application areas: Ford (Galaxy), Seat (Alhambra), Škoda and Volkswagen (Polo, Sharan)



115.1306	Central cable plug - grooved nut key	240
----------	--------------------------------------	-----

Door handle release tool

- For removal of the cap of door handles without lock cylinder
- Necessary for removal of the door handle
- For release of the locking hook in confined space
- With hanging hole
- With two component handle
- Chrome vanadium

Application range: Volkswagen Golf 6 from MY 08 / Fox from MY 05 / Passat B6 (3C) from MY / Tiguan from MY



	L1 mm	L2 mm	A mm	g
150.1609	260.0	150.0	10.0	140

Door hinge roll pin drift set

- For the dismantlement of instep cases in door hinges
- For all passenger car and transporter doors
- Surface zinc-plated
- Special steel



140.2190	4 pcs	Door hinge roll pin drift set	450
----------	-------	-------------------------------	-----

consists of:

		g
140.2191	Impact iron with PVC-handle, length 290 mm	366
140.2192	Extraction pin Ø 3.5 mm length 115 mm	12
140.2193	Extraction pin Ø 4.5 mm length 115 mm	19
140.2194	Extraction pin Ø 5.5 mm length 115 mm	25

Special door hinge and alignment wrench set

- For the assembly and disassembly of door hinges
- Ideally suitable for door alignment
- Extra short bits with ball locking
- Includes ratchet with bit adaptor
- In durable plastic storage case

Application range: Volkswagen, Audi, Seat, Mercedes, Renault, etc.

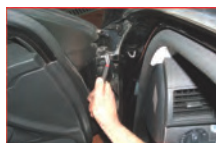

140.2180	9 pcs	Special door hinge and alignment wrench set	940
----------	-------	---	-----

consists of:

		g
140.2181	Double ended dual offset wrench, Length 300 mm	410
140.2182	5/16" Bit ratchet angled, Length 140 mm	110
140.2183	5/16" Special bit, XZN® M8	10
140.2184	5/16" Special bit, XZN® M10	10
140.2185	5/16" Special bit, XZN® M12	20
140.2186	5/16" Special bit, TORX® T30	10
140.2187	5/16" Special bit, TORX® T40	10
140.2188	5/16" Special bit, TORX® T45	10
140.2189	5/16" Special bit, TORX® T50	10

Universal straightening iron

- For alignment of passenger car and van doors
- Also suitable for car boot and hatchbacks
- Double-walled execution
- Includes 3 different interchangeable special bolts
- Storage of the 3 special bolts convenient in the pipe grip magazine
- Chrome plated and mirror polished
- Special steel



	L mm	Replacement bolt set 3 pcs	g
150.1605	700.0	150.1606	1.30

DOOR OPENER

Panel bag

- Universal usage for positioning, fixing and separating body parts
- Ideal for the damage-free opening of car doors
- Levelling tool for the installation of door and window frames
- Extremely high pressure power
- Easy to pump with the hand pump
- Robust panel bag



	L mm	B mm	g
116.1035	200.0	150.0	190

Panel bag set with hand pump

- Universal usage for positioning, fixing and separating body parts
- Ideal for the damage-free opening of vehicle doors
- Levelling tool for the installation of door and window frames
- For separating interior trim
- Pumping via a hand pump with valve connector
- Release valve on the bellows
- Extremely high pressure power



150.1685	4 pcs	Panel bag set with hand pump	300
----------	-------	------------------------------	-----

consists of:

		g
150.1686	Hand bellows	84
150.1687	Panel bag 180 x 40mm	23
150.1688	Panel bag 190 x 60mm	27
150.1689	Panel bag 180 x 160mm	47

Automobile car door lock opener set

- Wide range of round and fl t steel tools, nylon wedge and universal gas cap key
- For opening locked car doors from outside
- Ideal for towing service
- Can be used on most common vehicle models
- In durable leather case

Note: Does not work with modern vehicles with electronically controlled locking systems



Item No.	Description	Quantity	Weight (kg)
150.1630	16 pcs Automobile car door lock opener set	2.55	

consists of:

Item No.	Description	Quantity
150.1611	Door opening wire, button and auxiliary hook	90
150.1612	Door opening wire, double slide hook	70
150.1613	Door opening wire, Toyota Camry/Chrysler tool	10
150.1614	Door opening wire, Mercedes/Volvo tool	60
150.1615	Door opening wire, dual tool	30
150.1616	Door opening wire, Japanese/button hook	90
150.1617	Door opening wire, Porsche tool	20
150.1618	Door opening wire, Chevrolet Astro/ Camaro tool	60
150.1619	Door opening wire, double curve	20
150.1620	Door opening wire, button pull	20
150.1621	Door opening wire, wonder tool	140
150.1622	Strip type catches small f.150.1630	60
150.1623	Strip type catches wide f.150.1630	120
150.1624	Plastic strip f.150.1630	10
150.1625	Nylon window wedge f.150.1630	40
150.1626	Double ended fuel cap key f.150.1630	10

EXTERIOR MIRROR

Double ended mirror screwdriver

- Clip for the breast pocket
- Knurled grip
- Aluminium

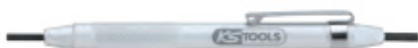

Item No.	D	L mm	Weight (kg)
140.2216	T15 x PH0	120.0	50
140.2217	2.0 mm x 3/32"	120.0	50
140.2218	T15 x T20	120.0	50

ERGOTORQUEplus® screwdriver for TX screws, tamperproof

- Perfectly suited to assembly and disassembly of wing mirrors
- With two component handle
- Optimal power transmission
- With suspension hole
- Hardened blade
- Chrome finish with burnished tips
- Blade made of chrome vanadium

Application range: Mercedes W203 (C Class) and W204 (E Class)



Item No.	L1 mm	L2 mm	L3 mm	Weight (kg)	
159.1054	TB20	205.0	100.0	105.0	50

ERGOTORQUEplus® T-handle TX key wrench, long

- Extra-long design
- With two component handle
- Continuous hardened
- Tip burnished
- Chrome plated and mirror polished
- Special steel

Application range: Fittings, engine, bumper, headlamps, fuse boxes, etc.



Item No.	Key	L1 mm	L2 mm	L3 mm	Weight (kg)
158.8051	T10	403.0	373.0	80.0	30
158.8052	T15	403.0	373.0	80.0	30
158.8053	T20	403.0	373.0	100.0	40
158.8054	T25	408.0	373.0	100.0	40
158.8055	T27	408.0	373.0	100.0	40
158.8056	T30	408.0	373.0	100.0	45

ERGOTORQUEplus® T-handle TX key wrench set

- Extra-long design
- With two component handle
- Continuous hardened
- Tip burnished
- Chrome plated and mirror polished
- Special steel

Application range: Fittings, engine, bumper, headlamps, fuse boxes, etc.

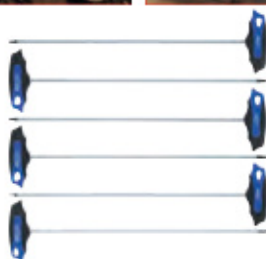
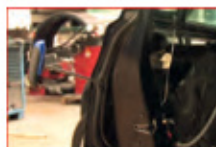

Item No.	Description	Weight (kg)
158.8050	6 pcs T10 - T15 - T20 - T25 - T27 - T30	375

Wing mirror pliers

- Perfectly suited to assembly and disassembly of wing mirrors
- With opening limits
- With adjusting screw and spring
- With PVC dipped handle
- Special tool steel

Application range: Wing mirrors for BMW E12, E21, E24, E28, E30, E31, E32, E34, E36, E38 and E39

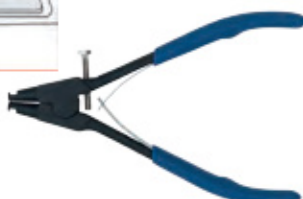

Item No.	Length mm	Weight (kg)
115.1305	165.0	180

LEVER AND SEPARATING TOOLS

Bending iron/pry bar

- 6-point
- Quenched and tempered
- Forged
- Cone polished
- Special steel

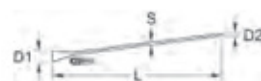

Item No.	D1 mm	D2 mm	L mm	S mm	Weight (kg)
129.2222	22.0	5.0	405.0	16.0	650

Pry bar

- Ideal for assembly and disassembly work
- Ergonomic one component handle
- Hardened through the whole length
- Chrome molybdenum

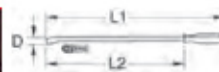
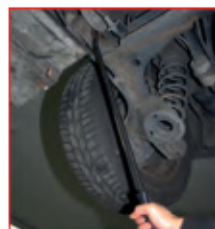

Item No.	D mm	L1 mm	L2 mm	Weight (kg)
911.8101	11.0	200.0	115.0	130
911.8102	15.0	300.0	185.0	220
911.8103	18.0	450.0	320.0	420
911.8104	18.0	600.0	470.0	560

Pry bar sets

- Ideal for assembly and disassembly work
- Ergonomic one component handle
- Hardened through the whole length
- Chrome molybdenum



Item No.	Quantity	Dimensions	Weight (kg)
911.8100	4 pcs	11 x 115 mm - 15 x 185 mm - 18 x 320 mm - 18 x 470 mm	1.33



Mechanics pry bar

- Angular lever end guarantees non-slip surface
- With go through blade and hammer cap
- Ideally suited to assembly and disassembly work
- For pressure testing securely-fitted parts
- Suitable for positioning parts or holding parts in place
- Suitable for the testing of defective bearings
- With two component handle
- Heavy design especially for commercial vehicles
- Special steel



	Head angle	L mm	kg
911.8411	0°	900.0	1.70
911.8412	45°	900.0	1.75
911.8413	75°	600.0	1.17
911.8414	90°	600.0	1.20
911.8415	45°	1120.0	4.75

Mechanics pry bar set

- Angular lever end guarantees non-slip surface
- With go through blade and hammer cap
- Ideally suited to assembly and disassembly work
- For pressure testing securely-fitted parts
- Suitable for positioning parts or holding parts in place
- Suitable for the testing of defective bearings
- With two component handle
- Heavy design especially for commercial vehicles
- Special steel
- In durable plastic storage case



		kg
911.8410	4 pcs. Mechanics pry bar set	8.70

consists of:

		kg
911.8411	Mechanics pry bar, straight 900 mm	1.70
911.8412	Mechanics pry bar 45°, angled head 900 mm	1.75
911.8413	Mechanics pry bar 75°, angled head 600 mm	1.17
911.8414	Mechanics pry bar 90°, angled head 600 mm	1.20

Interchangeable ratchet pry bar

- Extremely versatile and robust execution
- Variable adjustable roll head
- Maximum power transmission in the narrowest area
- Optimal leverage in minimal work area
- Ideally suited for commercial vehicles
- Special steel



	L mm	Assembly teeth	kg
911.8176	250.0	5	600
911.8177	300.0	5	600
911.8178	400.0	5	600
911.8179	620.0	5	1810



Adjustable joint roll head pry bar set

- Extremely versatile and robust execution
- Variable adjustable roll head
- Maximum power transmission in the narrowest area
- Optimal leverage in minimal work area
- Ideally suited for commercial vehicles
- Special steel



		kg
911.8175	3 pcs. Adjustable joint roll head pry bar set	1.20

consists of:

		kg
911.8176	Ratcheted pry bar, 10°	600
911.8177	Ratcheted pry bar, 12°	600
911.8178	Ratcheted pry bar, 15°	600

Telescopic flexible roll head pry bar

- Handle can be lengthened by the push button in ratchet steps
- Rolling head adjustable in stages
- Extra thin with embedded rolling head
- Maximum power in the smallest areas
- Optimal leverage in minimal work area
- Ideally suited to assembly and disassembly work
- For pressure testing securely-fitted parts
- Suitable for positioning parts or holding parts in place
- Suitable for the testing of defective bearings
- Ideal for use in passenger cars and commercial vehicles
- Special steel



	L mm	H mm	B mm	kg
911.8186	325-460	90.0	12.0	780
911.8187	600-915	120.0	20.0	1900
911.8188	865-1350	145.0	24.0	4260

Bodywork slitting chisel

- Suitable for separating welds
- With re-grindable cutters
- Continuous blade
- With two component handle
- Special steel



	L mm	A mm	B mm	H mm	kg
162.0216	300.0	25.0	19.0	6.0	330

Bodywork slitting chisel

- Suitable for separating welds
- With re-grindable cutters
- Continuous blade
- With two component handle
- Special steel



	L mm	A mm	B mm	H mm	kg
162.0217	300.0	25.0	19.0	6.0	330

Bodywork slitting chisel

- Suitable for separating welds
- With re-grindable cutters
- Continuous blade
- With two component handle
- Special steel

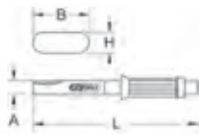

	L mm	A mm	B mm	H mm	Weight
162.0218	240.0	25.0	19.0	6.0	330

Bodywork slitting chisel set

- Suitable for separating welds
- With re-grindable cutters
- Continuous blade
- With two component handle
- Special steel



	Weight
162.0215 3 pcs Bodywork slitting chisel set	1.00

consists of:

	Weight
162.0216 Bodywork separating chisel, straight	330
162.0217 Bodywork separating chisel, 15° angled	330
162.0218 Bodywork separating chisel, 90° angled	330

Bodywork slitting chisel

- DIN 7255
- Flat oval form
- Blade can be resharpened
- Extra flit
- Burnished
- Chrome vanadium



	L mm	A mm	B mm	H mm	Weight
140.2162	300.0	21.0	25.0	6.0	310

Bodywork slitting chisel with hand grip

- DIN 7255
- Flat oval form
- Blade can be resharpened
- Extra flit
- Burnished
- Chrome vanadium

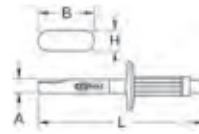

	L mm	A mm	B mm	H mm	Weight
140.2165	300.0	21.0	25.0	6.0	550

Bodywork slitting chisel

- Flat oval form
- Quenched and tempered
- Blade can be resharpened
- Shaft with gold coated lacquer
- Highly polished
- Chrome molybdenum



	L mm	A mm	B mm	H mm	Weight
162.0271	250.0	30.0	23.0	13.0	162.042 460

Slitting chisel with hand grip

- Flat oval form
- Extra thin
- Blade can be resharpened
- Quenched and tempered
- Shaft with gold coated lacquer
- Highly polished
- Chrome molybdenum

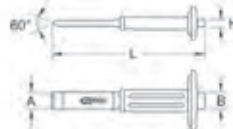

	L mm	A mm	B mm	H mm	Weight
162.0471	240.0	26.0	26.0	7.0	370

Bodywork spade chisel

- Extra wide execution
- With protective handgrip
- Quenched and through hardened
- For cutting metal sheet and spot welds
- Shaft with powder coated lacquer
- Special steel



	B mm	L mm	Weight
156.0330	60.0	240.0	600

Bodywork slitting chisel set

- Flat oval form
- Extensive range
- With re-grindable cutters
- Extra flit
- Bronzed, chrome vanadium
- Highly polished/chrome molybdenum



	Weight
140.2145 4 pcs Bodywork slitting chisel set	2.00

consists of:

	Weight
156.0330 Bodywork chisel, 60x240mm	600
140.2162 Slitting chisel no grip, 300mm	310
140.2165 Slitting chisel+grip, 300mm	550
162.0471 Slitting chisel, hand grip, 240mm	370

Pneumatic chisel set

- Non slip soft grip handle
- Air exhaust through the handle
- Ergonomic designed handle
- For ripping out car body sheet metal with pneumatic air
- Ideal for industry
- Also suitable for loosening firm y rusted fittings
- Quick release chuck for quick chisel changing
- Stepless impact regulation
- Vibration dampened
- Cold insulated handle
- Includes 1/4" coupling connector and chuck
- Ultra light housing from two component plastic
- In durable plastic case



Technical data:

Chisel holder:	10 mm
Number of blows:	2900 blows/min
Vibration:	5,35 ms ²
Noise performance level:	104.9 dbA
Noise pressure level:	90.4 dbA
Air consumption:	77.3 l/min
Operating pressure:	max. 6,3 bar (90 psi)
Connection thread:	1/4"PT

	Weight
515.3840 7 pcs Pneumatic chisel set	1.70

consists of:

	Weight
515.3841 AIR CHISEL	1.73
515.3842 Rivet cutting chisel	0.17
515.3843 Spot weld chisel	0.16
515.3844 Flat chisel	0.16
515.3845 Pointed chisel	0.16
515.3846 Curved sheet metal cutting chisel	0.16
515.3847 Quick change retainer	0.32

Vibro impact pneumatic chisel hammer set

- With non slip soft grip handle
- Air exhaust through the handle
- Ergonomic designed handle
- Ideal for industry
- Efficient, gentle loosening of screw fittings
- With stepless impact regulation
- Vibration dampened
- Cold insulated handle
- Includes 1/4" coupling connector
- Ultra light housing from two component plastic



515.3880	6 pcs	Vibro impact pneumatic chisel hammer set	5.70

consists of:

515.3881	Pneumatic chisel hammer	2.17	
515.3882	Holder for pneumatic chisel hammer	1.55	
515.3886	Pneumatic chisel track rod loosener, 110mm	0.14	
515.3887	Pneumatic chisel hammer, 110mm	0.15	
515.3888	Pneumatic chisel loosening adapter, 130mm	0.16	
515.3889	Pneumatic chisel loosening mandrel, 100x25x12mm	0.19	

Special Vibro chisel set

- For loosening seized screw joints and loosening components
- Gentle peeling and driving
- Vibration is transmitted directly to the screw connections
- Impact mandrel attachment as ingenious aid to any removal operation
- For hexagonal and round 10 mm machine mountings
- Including pressure plate adapter for driving out bearings, sleeves, bushings

Caution: Use only in conjunction with a pneumatic hammer chisel!

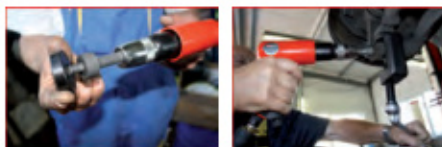

515.3885	4 pcs	Special Vibro chisel set	7.74

consists of:

515.3886	Pneumatic chisel track rod loosener, 110mm	1.38	
515.3887	Pneumatic chisel hammer, 110mm	1.48	
515.3888	Pneumatic chisel loosening adapter, 130mm	1.59	
515.3889	Pneumatic chisel loosening mandrel, 100x25x12mm	1.90	

BODY BORING TOOLS

SlimPOWER mini-pneumatic straight drill

- Straight design
- Air exhaust through the handle rear end
- For one handed operation with ergonomic design
- Not reversible
- With quick release chuck capacity 1 - 6,5 mm
- For hard to reach places
- Ideally suited for car bodywork and industrial working
- With stepless speed regulation
- Vibration dampened through double bearing guides
- Includes 1/4" coupling connector
- Robust housing



- Technical data:**
- Chuck capacity: 1 - 6,5 mm
 - Chuck thread reception: 3/8" x 24 UNF
 - Capacity: 190 Watt
 - No load current: 6000 r.p.m.
 - Vibration: < 0,7 ms²
 - Noise performance level: 95 dbA
 - Noise pressure level: 80 dbA
 - Air consumption: 240.66 l/min
 - Min. tube diameter: 1/4" - 4,8 mm
 - Operating pressure: max. 5,5 bar (80 psi)
 - Connection thread: 1/4"NPT

	B mm	L mm	
515.5020	35.5	145.0	400

Pneumatic straight drill

- Straight design
- Air exhaust through the handle rear end
- For one handed operation with ergonomic design
- Not reversible
- With quick release chuck capacity 0 - 10 mm
- For hard to reach places
- Ideally suited for car bodywork and industrial working
- With stepless speed regulation
- Number of revolutions adjustable through regulating screw
- Vibration dampened through double bearing guides
- Cold insulated handle
- Includes 1/4" coupling connector
- Ultra light robust housing from special plastic



- Technical data:**
- Chuck capacity: 1 - 10 mm
 - Chuck thread reception: 3/8" x 24 UNF
 - Capacity: 330 Watt
 - No load current: 2600 r.p.m.
 - Vibration: < 0,1 ms²
 - Noise performance level: 95 dbA
 - Noise pressure level: 82 dbA
 - Air consumption: 85 l/min
 - Min. tube diameter: 3/8" - 10 mm
 - Operating pressure: max. 6,3 bar (90 psi)
 - Connection thread: 1/4"NPT

	B mm	L mm	
515.3025	44.0	215.0	750

SlimPOWER mini-pneumatic angle drill

- Angled version
- Air exhaust through the handle rear end
- For one handed operation with ergonomic design
- Not reversible
- With gear rim drill chuck width 1 - 6,5 mm
- For hard to reach places
- Ideally suited for car body work
- With stepless speed regulation
- Vibration dampened through double bearing guides
- Includes 1/4" coupling connector
- Robust housing



- Technical data:**
- Chuck capacity: 1 - 6,5
 - Chuck thread reception: 3/8" x 24 UNF
 - Capacity: 230 Watt
 - No load current: 4500 r.p.m.
 - Vibration: < 0,7 ms²
 - Noise performance level: 95 dbA
 - Noise pressure level: 83 dbA
 - Air consumption: 240.66 l/min
 - Min. tube diameter: 1/4" - 6,4 mm
 - Operating pressure: max. 6,3 bar (90 psi)
 - Connection thread: 1/4"

	B mm	L mm	
515.5025	90.0	145.0	700

Pneumatic angle drill

- Angled version
- With planetary gearing
- Air exhaust through the handle rear end
- For one handed operation with ergonomic design
- Not reversible
- With gear rim drill chuck width 0 - 10 mm
- For hard to reach places
- Ideally suited for car body work
- With stepless speed regulation
- Number of revolutions adjustable through regulating screw
- Vibration dampened through double bearing guides
- Cold insulated handle
- Includes 1/4" coupling connector
- Ultra light robust housing from special plastic



- Technical data:**
- Chuck capacity: 1 - 10
 - Chuck thread reception: 3/8" x 24 UNF
 - Capacity: 330 Watt
 - No load current: 1800 r.p.m.
 - Vibration: < 0,15 ms²
 - Noise performance level: 95 dbA
 - Noise pressure level: 87 dbA
 - Air consumption: 85 l/min
 - Operating pressure: 6,3 bar (90 psi)
 - Min. tube diameter: 3/8" - 10 mm
 - Connection thread: 1/4"NPT

	L mm	B mm	
515.1265	200.0	100.0	1.15

Cordless drill machine

- Light weight
- Handy and ergonomic dual component housing
- Universal use through robust quick release chuck
- With practical clockwise and anticlockwise reversing function
- Stepless controllable motor speed through electronic switch
- With torque control
- Carbon brushes interchangeable
- With lithium ion high performance rechargeable battery
- Longer running time through higher load capacity
- Fast charging function (1 hour)
- Automatic turn off charging station
- Blow mould plastic housing
- In durable plastic storage case



Technical data:

Chuck capacity:	1 - 10 mm
Capacity:	10,8 V
Speed:	0 - 1870 rpm
Torque max.	24 Nm
No load current:	3,5 A
Charging time:	1 hour
Rechargeable battery:	10,8 V - 1,5 Ah

	L mm	B mm	H mm	Spindle lock	Battery dock	Number of charges	kg
515.3534	190,0	55,0	200,0	515.3595	515.3592	0	1,60
515.3535	190,0	55,0	200,0	515.3595	515.3592	1	2,50
515.3536	190,0	55,0	200,0	515.3595	515.3592	2	2,70

Pneumatic pistol grip drill

- Low rotation speed
- Non slip soft grip handle
- Ultra light robust housing from special plastic
- Air exhaust through the handle
- Quick release chuck capacity 0 - 13 mm
- Practical clockwise and anticlockwise switch
- Suitable for continuous duty
- Ideally suited for working with hard to machine materials
- For spot weld drills, polishing and grinding wheels, erasing rubbers etc.
- Very substantial guide
- Stepless speed regulation
- Vibration dampened
- Handle for 2 hand operation 360° revolving and lockable
- Cold insulated handle
- Includes 1/4" coupling connector



Technical data:

Chuck capacity:	1,5 - 13 mm
Chuck thread reception:	3/8" x 24 Gang
Capacity:	330 Watt
No load current:	450 r.p.m.
Vibration:	< 0,15 ms ²
Noise performance level:	95 dbA
Noise pressure level:	87 dbA
Air consumption:	113 l/min
Operating pressure:	max. 6,3 bar (90 psi)
Min. tube diameter:	3/8" - 10 mm
Connection thread:	1/4"NPT

	B mm	L mm	T mm	kg
515.3035	200,0	230,0	43,0	1,60

Pneumatic pistol grip drill

- Very handy and compact construction
- With non slip soft grip handle
- Air exhaust through the handle
- For one handed operation with ergonomic design
- With quick release chuck capacity 0 - 10 mm
- With practical clockwise and anticlockwise switch
- Suitable for continuous duty
- For working in hard to access areas
- Ideally suited for car bodywork and industrial working
- With stepless speed regulation
- Vibration dampened
- Cold insulated handle
- Includes 1/4" coupling connector
- Ultra light robust housing from special plastic



Technical data:

Chuck capacity:	1 - 10 mm
Chuck thread reception:	3/8" x 24 UNF
Capacity:	330 Watt
No load current:	1800 r.p.m.
Vibration:	< 0,1 ms ²
Noise performance level:	95 dbA
Noise pressure level:	82 dbA
Air consumption:	113 l/min
Operating pressure:	max. 6,3 bar (90 psi)
Min. tube diameter:	3/8" - 10 mm
Connection thread:	1/4"NPT

	B mm	L mm	kg
515.3030	165,0	150,0	920

Pneumatic spot weld drill

- Air exhaust through the handle
- Easy operation
- Suitable for continuous duty
- Ideally suited for internal and external spot welds
- For spot weld drills
- Very substantial guide
- With adjustable milling machine depth ring in steps of 0,05 mm
- With revolving and removable frame to the fixation on the object
- With large frame for deep lying points
- Feed achievement through pneumatic cylinder
- With stepless speed regulation
- Includes 1/4" coupling connector
- Robust machined housing



Technical data:

Drive:	Ø 8 mm with set screw
Capacity:	500 Watt
No load current:	1600 r.p.m.
Vibration:	< 0,3 ms ²
Noise performance level:	90 dbA
Noise pressure level:	81 dbA
Air consumption:	280 l/min
Operating pressure:	max. 6,3 bar (90 psi)
Min. tube diameter:	3/8" - 10 mm
Connection thread:	1/4" IG

	B mm	L mm	kg
515.1206	200,0	235,0	2,20

accessories:

		kg
515.1207	Counter bracket, small for 515.1206	300
515.1208	Counter bracket, large for 515.1206	500

Pneumatic spot weld drill set

- Air exhaust through the handle
- Easy operation
- Suitable for continuous duty
- Ideally suited for internal and external spot welds
- For spot weld drills
- Very substantial guide
- Adjustable milling machine depth ring in steps of 0,05 mm
- Revolving and removable frame on the fixation on the object
- Large frame for deep lying points
- Feed achievement through pneumatic cylinder
- Stepless speed regulation
- Includes 1/4" coupling connector
- Robust machined housing
- In durable plastic case



Technical data:

Drive:	Ø 8 mm with set screw
Capacity:	500 Watt
No load current:	1600 r.p.m.
Vibration:	< 0,2 ms ²
Noise performance level:	90 dbA
Noise pressure level:	81 dbA
Air consumption:	280 l/min
Operating pressure:	max. 6,3 bar (90 psi)
Min. tube diameter:	3/8" - 10 mm
Connection thread:	1/4" IG

		kg
515.1205	9 pcs Pneumatic spot weld drill set	2,20

consists of:

		kg
515.1206	1/2" pneumatic spot weld drill	2,20
515.1207	Counter bracket, small for 515.1206	0,30
515.1208	Counter bracket, large for 515.1206	0,50
332.0108	HSS-E spot weld drill, Ø 8,0mm	0,02
515.3361	Pneumatic tool oil, 100ml	0,25



Fastdrill pneumatic spot weld drill

- Special drive for high torque
- With non-slip soft-grip-handle
- Air exhaust through the handle
- Suitable for continuous duty
- Ideally suited for internal and external spot welds
- For carbide spot weld drills
- Very substantial guide
- With revolving and removable frame on the fixation on the object
- Feed achievement through pneumatic-cylinder
- With stepless speed regulation
- Cold insulated handle
- Includes 1/4" coupling connector
- Robust machined housing



Technical data:

Drive in mm	8 mm
Capacity:	280 Watt
No load current:	1000 r.p.m.
Vibration:	< 0,233 ms ²
Noise performance level:	95,4 dbA
Noise pressure level:	82,4 dbA
Air consumption:	340 l/min
Operating pressure:	6 bar
Min. tube diameter:	3/8" - 10 mm
Connection thread:	1/4"PT

	8 mm	L mm	kg
515.1311	175.0	315.0	1.85

accessories:

		kg
515.1312	Bracket, small, for Fastdrill	550
515.1313	Bracket, big, for Fastdrill	800

Fastdrill pneumatic spot weld drill set

- Special gearbox for high torque
- With non slip soft grip handle
- Air exhaust through the handle
- Suitable for continuous duty
- Ideally suited for internal and external spot welds
- For carbide spot weld drills
- Very substantial guide
- With revolving and removable frame on the fixation on the object
- Feed achievement through Pneumatic-cylinder
- With stepless speed regulation
- Cold insulated handle
- Includes 1/4" coupling connector
- Robust machined housing



Technical data:

Drive in mm	8 mm
Capacity:	280 Watt
No load current:	1000 r.p.m.
Vibration:	< 0,233 ms ²
Noise performance level:	95,4 dbA
Noise pressure level:	82,4 dbA
Air consumption:	340 l/min
Operating pressure:	6 bar
Min. tube diameter:	3/8" - 10 mm
Connection thread:	1/4"PT

		kg
515.1310	3 pcs Fastdrill pneumatic spot weld drill set	2.40

consists of:

		kg
515.1311	Fastdrill pneumatic spot weld drill	1.85
515.1312	Bracket, small, for Fastdrill	0.55
515.1314	T-handle wrench	0.04

COOLANT

Cooling lubricant stick

- Suitable for working with centre bits, countersinks and stepped drills
- Contents 18g
- To prolong the service life



	Volume g	kg
390.0190	18	44



SPOT WELD DRILLS

HSS Spot weld cutter

- Right hand cutting
- Interchangeable crowns
- Milling machine depth adjustable
- For efficient and fast working
- For loosening of spot welds
- No deformation of the sheet metal
- Special high performance steel

Ideally suitable with pneumatic drill, electric drill and rechargeable battery drill.

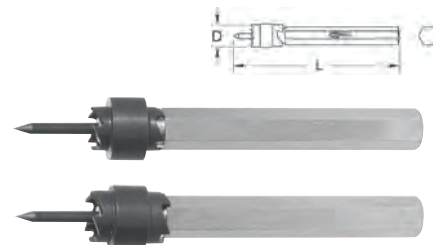

	D mm	D	L mm	Replacement crowns	Center point	Content	kg
332.0951	8.0	5/16	72.0	332.0952	332.0955	1	30
332.0953	10.0	3/8	72.0	332.0954	332.0955	1	30

HSS Spot weld cutter set

- Right hand cutting
- Interchangeable crowns
- Milling machine depth adjustable
- For efficient and fast working
- For loosening of spot welds
- No deformation of the sheet metal
- Special high performance steel

Ideally suitable with pneumatic drill, electric drill and rechargeable battery drill.



		kg
332.0950	2 pcs 8 - 10 mm	100

HSSE Spot weld drill

- Right hand cutting
- Centre tip has a ground point
- Accurate polished
- For burr free drilling without using a centre punch
- For the drilling of welding points
- Surface without discolouration
- High performance steel

Ideally suited in a hand drilling machine. For drilling of plastic sheet, copper, zinc, aluminum, brass and steel sheet.

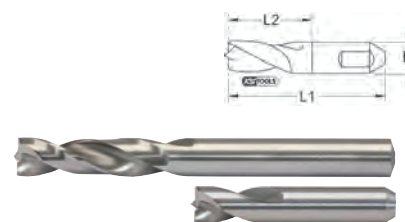

	D mm	L1 mm	L2 mm	Content	kg
332.0106	6.0	70.0	25.0	1	10
332.0108	8.0	80.0	30.0	1	20
332.0110	10.0	90.0	35.0	1	40

HSSE TIN Spot weld drill

- Right hand cutting
- Centre tip has a ground point
- Accurate polished
- For burr free drilling without using a centre punch
- For the drilling of welding points
- TIN coated surface
- High performance steel

Ideally suited in a hand drilling machine.
For drilling of plastic sheet, copper, zinc, aluminum, brass and steel sheet.

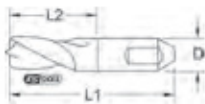

	D mm	L1 mm	L2 mm	Coat	Ø
332.0206	6.0	70.0	25.0	1	10
332.0208	8.0	80.0	30.0	1	20
332.0210	10.0	90.0	35.0	1	40

HSSE TiCN Spot weld drill

- Right hand cutting
- Centre tip has a ground point
- Accurate polished
- For burr free drilling without using a centre punch
- For the drilling of welding points
- TiCN coated surface
- High performance steel

Ideally suited in a hand drilling machine.
For drilling of plastic sheet, copper, zinc, aluminum, brass and steel sheet.

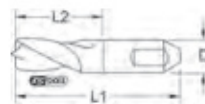

	D mm	L1 mm	L2 mm	Coat	Ø
332.0308	8.0	80.0	30.0	1	20
332.0310	10.0	90.0	35.0	1	40

HSS Spot weld drill

- Right hand cutting
- Centre tip has a ground point
- Accurate polished
- For burr free drilling without using a centre punch
- For the drilling of welding points
- TiCN coated surface
- High performance steel

Ideally suited in a pneumatic drill and vario milling machine.

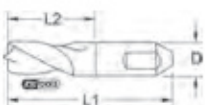

	D mm	L1 mm	L2 mm	Coat	Ø
332.0408	6.5	44.0	15.0	1	10
332.0708	8.0	44.0	15.0	1	10

HSSE TIN Spot weld drill

- Right hand cutting
- Centre tip has a ground point
- Accurate polished
- For burr free drilling without using a centre punch
- For the drilling of welding points
- TIN coated surface
- High performance steel

Ideally suited in a pneumatic drill and vario milling machine.

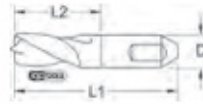

	D mm	L1 mm	L2 mm	Coat	Ø
332.0508	6.5	44.0	15.0	1	10
332.0808	8.0	44.0	15.0	1	10

HSSE TIN Spot weld drill

- Right hand cutting
- Centre tip has a ground point
- Accurate polished
- For burr free drilling without using a centre punch
- For the drilling of welding points
- TIN coated surface
- High strength steel

Ideally suited in a pneumatic drill and vario milling machine



	D mm	L1 mm	L2 mm	Coat	Ø
332.0809	8.0	44.0	23.0	10	134

HSSE TiCN Spot weld drill

- Right hand cutting
- Centre tip has a ground point
- Accurate polished
- For burr free drilling without using a centre punch
- For the drilling of welding points
- TiCN coated surface
- High performance steel

Ideally suited in a pneumatic drill and vario milling machine.



	D mm	L1 mm	L2 mm	Coat	Ø
332.0608	8.0	44.0	15.0	1	10

HSSE Double ended spot weld drill

- Right hand cutting
- Relieved cone has a ground point
- Cutting edge has thinning point
- 135° pointed angle
- Double ended usage
- Extra short and durable
- For thin walled materials
- Surface without discolouration
- High performance steel

Ideally suitable in steel, cast steel and high and low alloyed steel up to 900 N/mm² tensile, bronze, brass, brushed aluminum alloy, graphite, nickel silver, sintered iron, pressure-, malleable- and cast iron

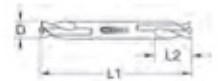

	D mm	L1 mm	L2 mm	Coat	Ø
332.0908	8.0	70.0	16.3	1	20

HSS Double ended spot weld drill set

- Right hand cutting
- Relieved cone has a ground point
- Cutting edge has thinning point
- 135° pointed angle
- Double ended usage
- Extra short and durable
- For thin walled materials
- Surface without discolouration
- High performance steel

Ideally suitable in steel, cast steel and high and low alloyed steel up to 900 N/mm² tensile, bronze, brass, brushed aluminum alloy, graphite, nickel silver, sintered iron, pressure-, malleable- and cast iron



	Ø
332.0938	3 pcs 3 x 332.0908 70

Carbide spot weld drill

- Right hand cutting
- Highest stability under load
- Double edged
- Welded carbide head
- Especially temperature resistance up to max. 1100° C
- High performance carbide
- Suitable for high strength car body panels

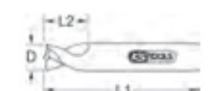

	D mm	L1 mm	L2 mm	Coat	Ø
515.1305	8.0	44.0	11.0	1	22
515.1308	10.0	44.0	11.0	1	25

BENDING AND PULLING TOOLS

Slide hammer

- Flexible removal tool
- Internal thread for holding various pullers, bolts and hooks
- Ideal for removing ball bearings, wheel hubs, etc.
- Ideal in confined spaces
- Special steel

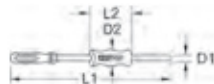

	L1 mm	L2 mm	D1 mm	D2 mm	Thread	Weight kg
660.0501	170	40.0	10.0	30.0	M10	0.40
660.0502	170	80.0	10.0	50.0	M10	0.90
660.0503	250	100.0	16.0	45.0	M10	1.30
660.0504	250	100.0	16.0	45.0	M10+G3/8"	1.40
660.0505	250	100.0	16.0	60.0	G3/8"	2.60

Universal slide hammer

- Extra heavy and solid execution
- For universal use for automobiles + trucks
- Enormous impact delivery of up to 11 tonnes
- With 6 kg impact weight
- Includes 3 kg additional weight
- With M 20 x 1.5 mm connection thread
- Additional weights can be screwed together
- Special steel



	L mm	Weight kg
700.1415	850.0	12.00

accessories:

	Weight kg
700.1421 Adaptor ET UN 1.1/2" x IT M20 x 1.5	0.72
700.1423 Adaptor for double hook	0.27
700.1424 Universal hook M20 x 1.5 for ball joints + car body	2.40
700.1425 Double hook	0.75
700.1428 Adaptor ET UN 1.1/2" x IT M16 x 2.0	0.72
700.1430 Adaptor ET UN 1.1/2" x IT M16 x 1.5	0.72
152.1056 Single screw adaptor AG M17 x 1	0.24
700.1411 Wheel hub/drive flange dismounting tool	2.55

Universal slide hammer with puller hook, 6+3 kg

- Suitable for use with tensioning clamps
- Extra heavy and solid execution
- For universal use for automobiles + trucks
- Enormous impact delivery of up to 11 tonnes
- With 6 kg impact force
- Includes 3 kg additional weight
- With M 20 x 1.5 mm connection thread
- Additional weights can be screwed together
- Special steel



	Weight kg
700.1475 3 pcs Universal slide hammer with puller hook, 6+3 kg	13.24

consists of:

	Weight kg
140.2455 Universal pull hook	1.00
700.1415 Universal slide hammer 6+3kg, 850mm	12.00

Edge hammering iron

- Suitable for professional hammering out edges and beads
- For hard-to-reach areas too
- Does not destroy the edges
- 4-edge handle for controlling the tool position in hollows
- Can be folded together
- Special steel



	Width mm	Length mm	Weight kg
140.2456	148.0	450.0	1.02

Universal clamping yoke

- Suitable for bodywork repairs
- Ideal for hammering our extremely deep lying areas
- Can be used with slide hammer (M20 x 1.5)
- Adjustable plastic slider for aluminium
- Robust design
- Special steel



	Width mm	Connector thread mm	Weight kg
140.2198	600.0	M20x1,5	5.70

Super spotter - Welding gun 220V - 50/60 Hz

- Handy workshop tool
- For the repair of bodywork damage
- For hammering out body panels
- Plastic housing

Technical data:

Attention idle cut-out: 200 Ampere
Attention light cut-out: 200 Ampere



	Length mm	Weight kg
500.8551	285.0	5.46

Slide hammer puller 1.5 kg

- For problem free hammering out of car bodywork panels
- With 1.5 kg slide weight
- Usable in connection with the super spotter
- Special steel



	Length mm	Height mm	Replacement spring-head	Weight kg
500.8559	475.0	80.0	500.8561	2.08

Super spotter - Welding gun set

- Handy workshop tool
- For the repair of bodywork damage
- For hammering out body panels
- By means of special electrodes nails or washers are welded on the sheet metal so the dents can be removed with an impact hammer using accurate blows
- With a heat electrode placed hot points can be set on the sheet metal
- Also contains an electrode for welding copper-plated dome head screws for the reinforcement of housings, parts, etc. directly on the bodywork
- In durable plastic storage case

Technical data:

Attention idle cut-out: 200 Ampere
Attention light cut-out: 200 Ampere



	Weight kg
500.8550 Super spotter - Welding gun set	10.39

consists of:

500.8551	Welding gun 220V, 50/60 Hz	5460	
500.8554	Electrode for welding nails, Copper	10	
500.8556	Electrode for rivets, magnetic, Copper	10	
500.8557	Electrode for washers, Brass	10	
500.8558	Heating electrode for hot spots, Brass	10	
500.8559	Slide hammer puller 1.5 kg	2080	
500.8560	Electrode extension, brass	10	
500.8571	Spotter-consumables, welding nails copper coated, 2.0 x 50 mm, pcs 500	660	
500.8572	Spotter-consumables, copper plated, welding nails, 2.5 x 50 mm, pcs 100	210	
500.8574	Spotter-consumables, 3 x 3.2 mm, pcs 100	30	
500.8579	Spotter-consumables, screws copper coated, M 4 x 16 mm, pcs 100	140	
500.8592	Washers 8.0 x 16.0 mm copper coated pcs 100	160	

Super spotter additional kit

- For removing of car body damage
- Includes the adaptor for the slide hammer puller
- The flexible and strong steel wire profile is used so the processing of securing car body panels
- The movable pull hooks situated can be pulled by the claw fastener straightening the car body and/or the bump on
- It can be hooked on 1-9 pull hooks, at what point exact or extensive enabling the removal of dents



500.8530	15 pcs Super spotter additional kit	1.04	

consists of:

500.8531	Welding-Electrode for corrugated wire for Spotter 500.8550	23	
500.8532	Corrugated wire Ø 2 mm x L=310 mm 10 pcs.	122	
500.8533	Corrugated wire positioner magnetic	34	
500.8534	Multi hook head with 5 claw connection IG M14x 1.5	315	
500.8536	System adaptor for slide hammer puller IG M14x1.5, for use with 500.8559	86	
500.8572	Spotter consumables, copper plated, welding nails, 2.5 x 50 mm, pcs 100	210	

Super spotter electrodes

- Usable in connection with the super spotter
- Copper and/or brass



500.8554	Electrode for welding nails, Copper	10	
500.8556	Electrode for rivets, magnetic, Copper	10	
500.8562	Electrode for screws, Copper	20	
500.8557	Electrode for washers, Brass	10	
500.8558	Heating electrode for hot spots, Brass	10	
500.8560	Electrode extension, brass	10	

Super spotter consumables

- Usable in connection with the super spotter
- For the reinforcement of the car body
- Copper coated



500.8570	Welding nail, 100pcs, 2x50mm	140	
500.8571	Welding nail, 500pcs, 2x50mm	660	
500.8572	Welding nail, 100pcs, 2.5x50mm	210	
500.8573	Welding nail, 500pcs, 2.5x50mm	1150	
500.8592	Washer, 100pcs, 8x16mm	160	
500.8595	Triangular-washer 2.5 x 50.0 mm copper coated 100pcs	500	
500.8574	Rivet, 100pcs, 3x3.2mm	30	
500.8575	Rivet, 100pcs, 3x4.5mm	40	
500.8576	Rivet, 100pcs, 5x8.2mm	40	
500.8579	Screw, 100pcs, M4x16mm	140	

Hydraulic vehicle alignment tool kit, 4 t

- For pressing, clamps and spreading of car body parts
- Simple handling due to plug in connection
- Includes hydraulic hand pump/ high pressure cylinder 4 t, detachable handle, pressure plate, and various attachments
- Special steel
- In durable plastic storage case with handle



160.0445	15 pcs Hydraulic vehicle alignment tool kit, 4 t	17.50	

consists of:

160.0446	Hydraulic-Pump for bodywork alignment tool, 4 t	5.20	
160.0447	Hydraulic-piston for bodywork alignment tool, 4 t	1.80	
160.0448	Extension tube for bodywork alignment tool, 400 mm	1.20	
160.0449	Extension tube for bodywork alignment tool, 300 mm	0.96	
160.0451	Extension tube for bodywork alignment tool, 200 mm	0.70	
160.0452	Extension tube for bodywork alignment tool, 100 mm	0.45	
160.0453	Adaptor extension	0.20	
160.0454	Pressure plate 110 x 65 mm	0.75	
160.0455	Pressure plate, V form	0.13	
160.0456	Piston attachment (laterally offset)	0.34	
160.0457	Wedge adaptor (notched)	0.21	
160.0458	Rubber ball, Ø 67 mm	0.26	
160.0459	Adaptor head, Cylinder serrated Ø: 35 mm	0.20	
160.0461	Pressure plate (laterally offset)	0.31	
160.0462	Adaptor for bodywork alignment tool, 4 t	1.73	

Hydraulic alignment tool kit, 10 t

- For pressing, clamps and spreading of car body parts
- Simple handling due to plug in connection
- Includes hydraulic hand pump/ high pressure cylinder 10 t, detachable handle simple handling due to plug in connection
- Special steel
- In durable wheeled storage case



160.0175	17 pcs Hydraulic alignment tool kit, 10 t	41.00	

consists of:

160.0176	Hydraulic pump f.body repair kit, 10 t	7.00	
160.0177	Hydraulic piston f.body repair kit, 10 t	5.55	
160.0178	Adaptor f.bodywork alignment tool	1.93	
160.0179	Extension tube f.body repair kit, 530mm	3.34	
160.0180	Extension tube f.body repair kit, 400mm	1.66	
160.0181	Extension tube f.body repair kit, 300mm	1.70	
160.0182	Extension tube f.body repair kit, 175mm	1.70	
160.0183	Adaptor f.body repair kit, MxM	1.66	
160.0184	Pressure plate, V form	1.14	
160.0185	Pressure plate, 150x95mm	0.66	
160.0186	Wedge adaptor (notched)	0.66	
160.0187	Pressure plate (laterally offset)	0.86	
160.0188	Piston attachment (laterally offset)	0.86	
160.0189	Rubber ball, Ø 80 mm	0.66	
160.0190	Adaptor head, cylinder serrated Ø 50 mm	1.14	

Clamp for preparation working

- Ideally suited to avoiding deformations during preparation working
- Central tube can be rotated to short or lengthen the spanner
- With two adjustable jaws
- Robust design
- Special steel

Application range: Boot, engine compartment, etc.



Opening of jaws min: 1000.0 mm
 Jaw width max: 1200.0 mm
 Width replacement jaws: 100.0 mm

700.1445	700.1446	5.00	

Universal tensioning clamp straightening iron

- Suitable for bodywork repairs and pulling
- 2 adjustable jaws for secure attachment
- Includes 2 blades
- Maximum load 5 tonnes
- Universal application by adjusting the adjustable jaws
- Robust design
- Special steel

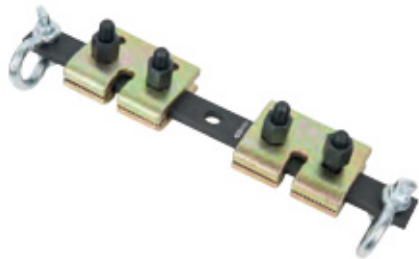

	L mm	Width adjustment jaws mm	
700.1457	450.0	120	6260

Mini pull clamp

- Two directions of pull
- Eyelet can be mounted to the left and right
- Ideal for car body repairs
- Extremely versatile
- Special steel

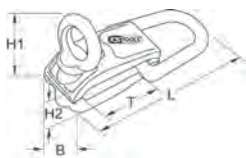

	L mm	B mm	H1 mm	H2 mm	T mm	Fixing bolt	
140.2400	150.0	36.0	100.0	42.0	27.0	M12x1,75	930

Standard pull clamp

- One direction of pull
- Ideal for car body repairs
- Extremely versatile
- Special steel

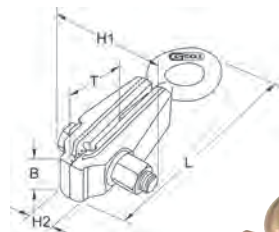

	L mm	B mm	H1 mm	H2 mm	T mm	Fixing bolt	
140.2405	220.0	44.0	90.0	22.0-42.0	32.0	M17x90	1.95

Standard pull clamp with 2 pull directions

- Two directions of pull
- Ideal for car body repairs
- Extremely versatile
- Special steel

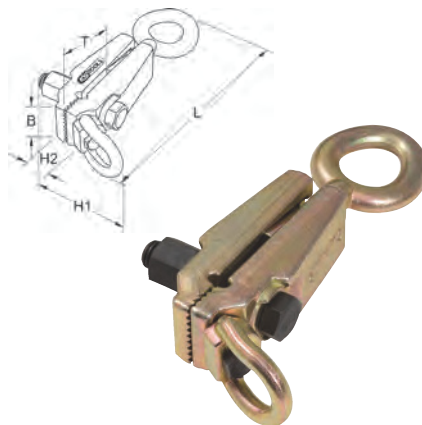

	L mm	B mm	H1 mm	H2 mm	T mm	Fixing bolt	
140.2410	220.0	44.0	125.0	22.0-80.0	32.0	M17x90	2.13

Small pull clamp

- One direction of pull
- No distorting due to the security device
- Ideal for car body repairs
- Extremely versatile
- Special steel



	L mm	B mm	H1 mm	H2 mm	T mm	Fixing bolt	
140.2415	255.0	32.0	85.0	23.0-42.0	70.0	M14x85	1.65

Box pull clamp

- One direction of pull
- Extra instep
- Ideal for car body repairs
- Extremely versatile
- Special steel

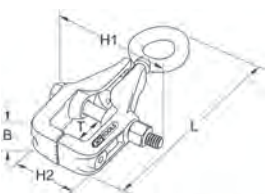

	L mm	B mm	H1 mm	H2 mm	T mm	Fixing bolt	
140.2420	245.0	38.0	130.0	80.0-85.0	64.0	M14x130	2.04

Box pull clamp with adaptable jaws

- One direction of pull
- Extra instep
- Ideal for car body repairs
- Extremely versatile
- Special steel

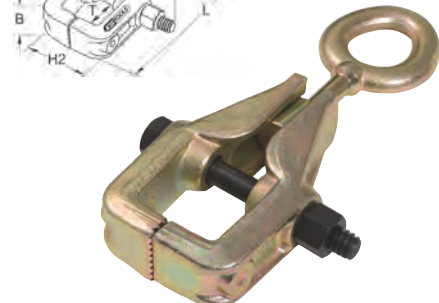
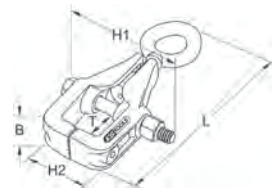

	L mm	B mm	H1 mm	H2 mm	T mm	Fixing bolt	
140.2425	245.0	38.0	130.0	80.0-85.0	64.0	M14x130	2.01

Box pull clamp with 2 pull directions

- Two directions of pull
- Ideal for car body repairs
- Extremely versatile
- Special steel

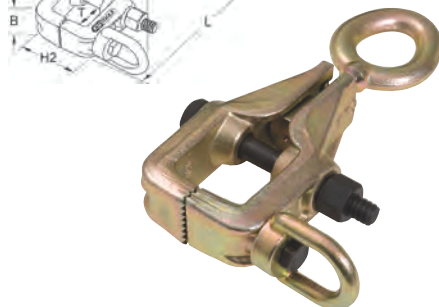
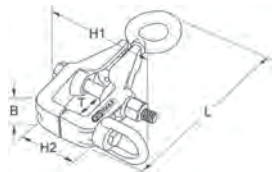

	L mm	B mm	H1 mm	H2 mm	T mm	Fixing bolt	
140.2430	245.0	38.0	155.0	80.0-145.0	64.0	M14x130	2.21

Maxi pull clamp

- One direction of pull
- With extra large mouth
- Ideal for car body repairs
- Extremely versatile
- Special steel

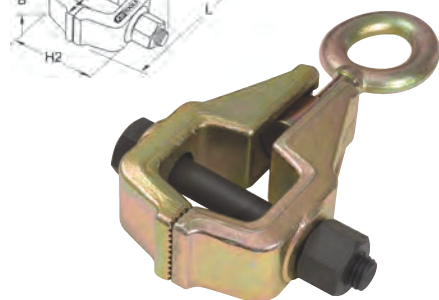
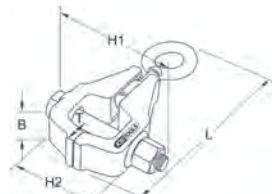

	L mm	B mm	H1 mm	H2 mm	T mm	Fixing bolt	
140.2435	240.0	46.0	150.0	20.0-100.0	42.0	M19x150	3.00

Double jaw pull clamp

- One direction of pull
- No distorting due to the security device
- Ideal for car body repairs
- Extremely versatile
- Special steel

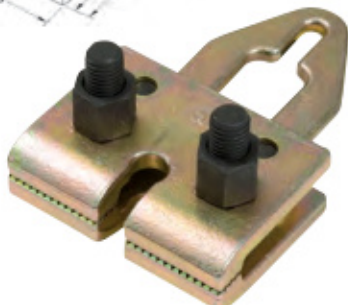
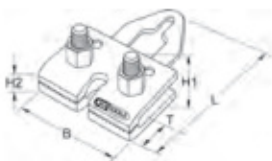

	L mm	B mm	H1 mm	H2 mm	T mm	Flange mm	Weight kg
140.2440	175.0	120.0	90.0	22.0-36.0	32.0	M17x90	2.49

Single-ended tensioning clamp

- One direction of pull
- With extra-large mouth
- Ideal for car body repairs
- Solid design
- Special steel



	L mm	B mm	T mm	Flange mm	Weight kg
140.2404	170.0	40.0	32.0	M14x90	1.20

Double jaw pull clamp with 2 pull directions

- Two directions of pull
- No distorting due to the security device
- Ideal for car body repairs
- Extremely versatile
- Special steel

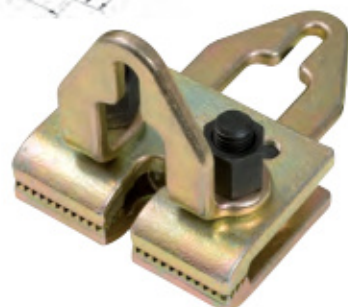

	L mm	B mm	H1 mm	H2 mm	T mm	Flange mm	Weight kg
140.2445	175.0	120.0	140.0	22.0-135.0	32.0	M17x90	2.86

Double jaw pull clamp with 3 pull directions

- Three directions of pull
- No distorting due to the security device
- Ideal for car body repairs
- Extremely versatile
- Special steel



	L mm	B mm	H1 mm	H2 mm	T mm	Flange mm	Weight kg
140.2450	175.0	120.0	140.0	22.0-135.0	32.0	M17x90	3.40

V tensioning clamp

- One direction of pull
- Ideal for car body repairs
- Solid design
- For use alongside the universal slide hammer (700.1415), adaptor (700.1421), and double hook (700.1425)
- Special steel



	L mm	B mm	Flange mm	Weight kg
140.2436	135.0	35.0	M12x70	0.67

Universal pull hook

- Universal car bodywork pull hooks
- Ideally suited for all ring eyelet tools
- High quality and compensated alloy steel
- Special steel



	Weight kg
140.2455	2 pcs Universal pull hook 1.00

Pulling chain connector

- Ideal for connecting or shortening pulling chains
- Suitable for 3/8" and 5/16" chains
- Maximum load 10 tonnes
- Simple, secure and easy to use
- Special steel



	Total length mm	Weight kg
140.2462	255.0	1.22

Universal bodywork tensioning clamp

- Ideal for car body repairs
- One direction of pull
- For narrow spaces
- Solid design
- Special steel



	Length mm	Width mm	Height mm	Weight kg
140.2469	260.0	35.0	30.0	1.85

Universal tension plate

- Universal bodywork tensioning plate
- A variety of holes for aligning any standard frame and many module chassis
- Ideal for car body repairs
- Solid design
- Special steel



	Length mm	Width mm	Height mm	Weight kg
140.2460	300.0	75.0	12.0	1.00

Wing puller, small

- Ideal for removing the wings
- Suitable for universal use thanks to the different arches
- Also suitable for adjusting headlamp openings and door pillars
- Tensile force is distributed when pulling
- Special steel

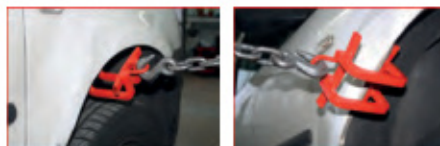

	Length mm	Width mm	Height mm	Weight kg
140.2465	160.0	220.0	80.0	1.50

Wing puller, large

- Ideal for removing the wings
- Suitable for universal use thanks to the different arches
- Also suitable for adjusting headlamp openings and door pillars
- Tensile force is distributed when pulling
- Special steel

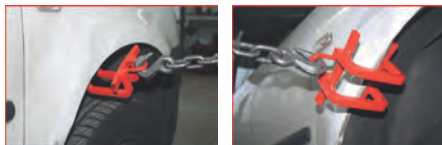

	Length mm	Width mm	Height mm	Weight kg
140.2470	320,0	235,0	80,0	1,80

HAMMERING TOOLS

Heel dolly set

- Ideal for removing dents
- Ideal for hail damage
- Various head forms
- Simple handling
- Plastic handles
- With practical carrying bag
- Special steel

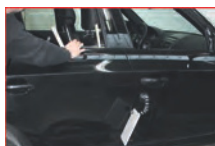

	Weight kg
140.2490 11 pcs Heel dolly set	3,80

consists of:

	Weight kg
140.2491 Semi-circular iron, 260 mm	100
140.2492 Semi-circular iron, 230 mm	100
140.2493 Round iron, 470 mm	150
140.2494 Semi-circular pointed iron, 970 mm	120
140.2495 Ball head iron, angled 500 mm	400
140.2496 Ball head iron, angled, 1000 mm	120
140.2497 Special iron with hook, 670 mm	300
140.2498 Ball head iron, twice angled, 600 mm	500
140.2499 Set of plastic tips, 3 pcs.	240

Aluminium panel beating hammer set

- For hammering out the car body
- Ideal for small dents and stone chips
- Replaceable plastic heads
- For gentle sheet metal working
- PVC dipped handle



	Weight kg
140.5290 5 pcs Aluminium panel beating hammer set	375

consists of:

	Weight kg
140.5291 Panel beating hammer	333
140.5292 Plastic head, flat	13
140.5293 Plastic head, cone-shaped/long	9
140.5294 Plastic head, cone-shaped/short	8
140.5295 Plastic head, cylindrical	13

Mini precision hammer set

- For hammering out the car body
- Ideal for small dents and stone chips
- Metal and plastic head for gentle sheet metal working
- Flexible handle in cone form



	Hammer Ø mm	Head length mm	Total length mm	Weight kg
140.5296 3 pcs	63	24,0	43,0	180,0

consists of:

	Weight kg
140.1246 Mini precision hammer, 180 mm	53
140.1247 Metal head, curved	15
140.1253 Plastic head, curved	7



Mini precision hammer set

- For hammering out the car body
- Ideal for small dents and stone chips
- Various metal and plastic heads for gentle sheet metal working
- Flexible handle in cone form
- In durable plastic storage case



	Weight kg
140.1245 7 pcs Mini precision hammer set	242

consists of:

	Weight kg
140.1246 Mini precision hammer, 180 mm	53
140.1247 Metal head, curved	15
140.1248 Aluminium head, curved	6
140.1249 Copper head, curved	18
140.1251 Copper head, cylindrical	25
140.1252 Plastic head, cylindrical	4
140.1253 Plastic head, curved	7

Universal panel beating hammer set

- For hammering out the car body
- Practical configuration
- For stretching and forming of car body sheet panels
- Hammer with 9 different attachments
- Special steel
- In durable plastic storage case



	Weight kg
140.5245 14 pcs Universal panel beating hammer set	1,00

consists of:

	Weight kg
140.5246 Universal hammer	190
140.5247 Corrugated attachment, coarse	66
140.5248 Corrugated attachment, fin	68
140.5249 Hammering attachment, smooth	74
140.5250 Hammering attachment, aluminium	32
140.5251 Hammer attachment, copper	82
140.5253 Hammer attachment, plastic	12
140.5261 Tip attachment, conical/flat	64
140.5262 Tip attachment, cone-shaped/tip	40
140.5263 Wedge adaptor	67
140.5264 Set of headless screws, 4 pcs.	4
140.5265 Burr arbour	15
151.2602 BASIC key wrench, hex, short, 2mm	10

Kit of teflon edges for varnished surface

- Ideal for reforming an over-compressed dent
- Hammering out without damage to paint
- Ridges are hammered out with targeted use of the hammer on the dents
- Also ideal for releasing tensioning in the sheet metal
- With interchangeable attachments
- Includes 2 handles
- Very rugged plastic

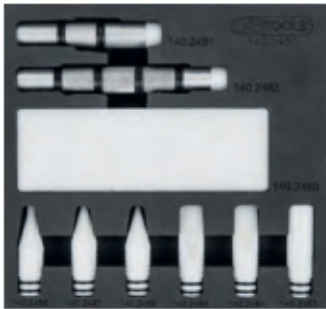

140.2480	10 pcs	Kit of teflon edges for varnished surface	280
----------	--------	---	-----

consists of:

140.2481	Handle, short, 90 mm	32
140.2482	Handle, long, 130 mm	50
140.2483	Cylinder-shaped impact head	16
140.2484	Impact head, wedge-shaped, round	13
140.2485	Impact head, wedge-shaped, square	12
140.2486	Impact head, cone-shaped, tip	10
140.2487	Impact head, cone-shaped, round	11
140.2488	Cylinder-shaped impact head with cone	10
140.2489	Set of strike plates, 2 pcs., 155 mm	120

Dent mirror

- Ideal for better identification of dents and bumps, e.g. hail damage
- Also suitable for mobile use
- With suction foot for straightforward use in the vehicle
- Freely adjustable using a gooseneck arm
- Arm can be easily separated from the screen with a snap lock for better transport
- Plastic



140.2597	Length mm	Width mm	Weight kg
	240.0	200.0	370

Dent mirror with light

- Ideal for better identification of dents and bumps, e.g. hail damage
- Also suitable for mobile use
- Stripes are projected on to the paint by penetration
- With suction foot for straightforward use in the vehicle
- Freely adjustable using a gooseneck arm
- Arm can be easily separated from the screen with a snap lock for better transport
- 230 V cable connector
- Closed plastic housing



140.2598	Length mm	Width mm	Weight kg
	360.0	203.0	1480

Professional slide hammer set

- Suitable for repairing small dents or bumps
- No filling or painting work
- Allows the flexible removal of the dent and provides the best results
- Includes small slide hammer
- With 10 different beating pads

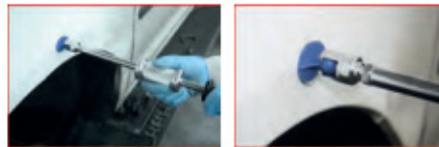

140.2510	11 pcs	Professional slide hammer set	896
----------	--------	-------------------------------	-----

consists of:

914.0066	Slide hammer	860
140.2501	Self-adhesive sheets, round, Φ t, Φ 40 mm	5
140.2511	Self-adhesive sheets, round, Φ t, Φ 35 mm	4
140.2521	Self-adhesive sheets, round, Φ t, Φ 32 mm	4
140.2531	Self-adhesive sheets, spherical, round, Φ 25 mm	3
140.2541	Self-adhesive sheets, spherical, round, Φ 20 mm	3
140.2551	Self-adhesive sheets, spherical, round, Φ 15 mm	2
140.2561	Self-adhesive sheets, elliptical, Φ t, 48 x 33 mm	5
140.2571	Self-adhesive sheets, elliptical, Φ t, 40 x 27 mm	4
140.2581	Self-adhesive sheets, elliptical, Φ t, 33 x 22 mm	3
140.2591	Self-adhesive sheets, rectangular, 32 x 17 mm	3

Professional smart-repair dent puller set

- Suitable for repairing small dents or bumps
- No filling or painting work
- Allows the flexible removal of the dent and provides the best results
- Includes dent-pulling unit with rubber support feet
- With 10 different beating pads



914.0065	11 pcs	Professional smart-repair dent puller set	316
----------	--------	---	-----

consists of:

914.0067	Dent-pulling unit with rubber support feet	280
140.2501	Self-adhesive sheets, round, Φ t, Φ 40 mm	5
140.2511	Self-adhesive sheets, round, Φ t, Φ 35 mm	4
140.2521	Self-adhesive sheets, round, Φ t, Φ 32 mm	4
140.2531	Self-adhesive sheets, spherical, round, Φ 25 mm	3
140.2541	Self-adhesive sheets, spherical, round, Φ 20 mm	3
140.2551	Self-adhesive sheets, spherical, round, Φ 15 mm	2
140.2561	Self-adhesive sheets, elliptical, Φ t, 48 x 33 mm	5
140.2571	Self-adhesive sheets, elliptical, Φ t, 40 x 27 mm	4
140.2581	Self-adhesive sheets, elliptical, Φ t, 33 x 22 mm	3
140.2591	Self-adhesive sheets, rectangular, 32 x 17 mm	3

Pneumatic smart-repair dent puller set

- Suitable for repairing small dents or bumps
- No filling or painting work
- Allows the flexible removal of the dent and provides the best results
- Includes pneumatic dent puller
- With 10 different beating pads



140.2520	12 pcs	Pneumatic smart-repair dent puller set	1,48
----------	--------	--	------

consists of:

140.2522	Pneumatic hammering puller		1440
140.2501	Self-adhesive sheets, round, fl t, Ø 40 mm		5
140.2511	Self-adhesive sheets, round, fl t, Ø 35 mm		4
140.2521	Self-adhesive sheets, round, fl t, Ø 32 mm		4
140.2531	Self-adhesive sheets, spherical, round, Ø 25 mm		3
140.2541	Self-adhesive sheets, spherical, round, Ø 20 mm		3
140.2551	Self-adhesive sheets, spherical, round, Ø 15 mm		2
140.2561	Self-adhesive sheets, elliptical, fl t, 48 x 33 mm		5
140.2571	Self-adhesive sheets, elliptical, fl t, 40 x 27 mm		4
140.2581	Self-adhesive sheets, elliptical, fl t, 33 x 22 mm		3
140.2591	Self-adhesive sheets, rectangular, 32 x 17 mm		3
140.2523	Extension adaptor		37

Self-adhesive sheets for hammering tools

- Suitable for repairing small dents or bumps
- No filling or painting work
- Allows the flexible removal of the dent and provides the best results
- For use alongside a planishing tool



Content			
140.2505	5 Self-adhesive sheets, round, fl t, Ø 40 mm, 5 pcs		25
140.2515	5 Self-adhesive sheets, round, fl t, Ø 35 mm, 5 pcs		20
140.2525	5 Self-adhesive sheets, round, fl t, Ø 32 mm, 5 pcs		20
140.2535	5 Self-adhesive sheets, spherical, round, Ø 25 mm, 5 pcs		15
140.2545	5 Self-adhesive sheets, spherical, round, Ø 20 mm, 5 pcs		15
140.2555	5 Self-adhesive sheets, spherical, round, Ø 15 mm, 5 pcs		10
140.2565	5 Self-adhesive sheets, elliptical, fl t, 48 x 33 mm, 5 pcs		25
140.2575	5 Self-adhesive sheets, elliptical, fl t, 40 x 27 mm, 5 pcs		20
140.2585	5 Self-adhesive sheets, elliptical, fl t, 33 x 22 mm, 5 pcs		15
140.2595	5 Self-adhesive sheets, rectangular, 32 x 17 mm, 5 pcs		15

Pneumatic vacuum dent puller set

- Ideal for processing bumps in bodywork
- A vacuum creates an underpressure and the suction disks stick to the bodywork allowing dents to be easily pulled out
- Pneumatic regulation via ball valve
- Includes 3 exchangeable suction discs and 1 pull hook
- Special steel
- In durable plastic storage case



Technical data:

- Operating pressure: 6 - 8 bar
- Min. tube diameter: 1/4" - 6.3mm
- Connection thread: 1/4"
- Slide hammer weight: 1.2 Kg
- Removal power: bis zu 100 Kg

140.2080	5 pcs	Pneumatic vacuum dent puller set	4.50

consists of:

140.2083	Panel beating hammer with impact weight		2400
140.2084	Suction disk Ø 75 mm		126
140.2085	Suction disk Ø 100 mm		170
140.2086	Suction disk Ø 125 mm		260
140.2087	Pull hook		100

Aluminium hammer

- With hickory handle
- Aluminium head
- Protective material



	g	D mm	L1 mm	L2 mm	handle spore		
140.2121	280	30.0	310.0	145.0	140.2122	140.2123	380

Aluminium bodywork hammering set

- For hammering out aluminium car body panels
- Practical configuration
- For stretching and forming of aluminium car body sheet panels
- In durable plastic storage case



140.2475	7 pcs	Aluminium bodywork hammering set	3.50

consists of:

140.2476	Aluminium bodywork recess heel dolly		186
140.2477	Aluminium bodywork comma heel dolly		350
140.2478	Aluminium bodywork universal heel dolly		210
140.2479	Aluminium bodywork toe heel dolly		265
700.1489	Aluminium bodywork pick hammer curved head, round/tip		110
700.1490	Aluminium bodywork fl t pick hammer curved head, round/fl t tip		140
700.1491	Aluminium bodywork standard hammer curved head, round/square		148

Panel beater's serrated hammer, round/tip

- For reworking repaired areas
- Stresses are removed from the plate using a special profile in the impact area
- For tightening with a round, rough serrated head
- Fine face curved for accurate hammering out
- Special steel



	Length mm	head length mm	Ø round side mm	Tip width mm	
140.2109	280.0	120.0	40.0	20.0	460

Panel beaters hammer

- With ash handle
- Forged execution
- Impact area surfaces inductively hardened
- Head and edge areas polished ground
- Rounded edges
- Head coating made from structured powder baked lacquer
- Hammer head made out of high quality special steel



	g	D mm	L1 mm	L2 mm	handle spore		
140.4003	400	30.0	310.0	118.0	140.5304	140.5404	560

Panel beaters hammer, small round/square

- Simple hammer with a fl t, angular face and a round, slightly arched face
- Work areas ground
- Special steel



	L mm	head length mm	Ø round side mm	square dim. mm	
140.2138	325.0	100.0	30.0	28 x 28 mm	390

Panel beaters standard hammer, large round/square

- Planishing hammer with a square and round, fl t face
- Work areas ground
- Special steel



	L mm	head length mm	Ø round side mm	square dim. mm	
140.2133	325.0	100.0	40.0	39 x 39 mm	420

Panel beaters serrated hammer fin , round/square

- For forming with a square, rough serrated face
- For stretching with a round, slightly domed face
- Round work surfaces ground
- Special steel



	L mm	head length mm	Ø head side mm	square dia mm	Weight kg
140.2139	325.0	100.0	40.0	38 x 38 mm	490

Panel beaters serrated hammer, round/square

- For forming with a square, finely serrated face
- For stretching with a round, slightly domed face
- Round work surfaces ground
- Special steel



	L mm	head length mm	Ø head side mm	square dia mm	Weight kg
140.2132	325.0	100.0	40.0	38 x 38 mm	490

Panel beaters hammer, round/square

- Bumping hammer with strong arched faces
- Work areas ground
- Special steel



	L mm	head length mm	Ø head side mm	square dia mm	Weight kg
140.2130	325.0	105.0	30.0	26 x 26 mm	390

Panel beaters hammer rounded head, small round/square

- Simple hammer with a fl t, angular face and a round, slightly arched face
- Work areas ground
- Special steel



	L mm	head length mm	Ø head side mm	square dia mm	Weight kg
140.2135	325.0	100.0	30.0	27 x 27 mm	390

Aluminium bodywork pick hammer curved head, round/ tip

- For hammering out aluminium car body panels
- Planishing hammer with a round, slightly domed face
- Fine conical face for accurate hammering out
- Polished surface
- Aluminium



	L mm	head length mm	Ø round side mm	Weight kg
700.1489	300.0	140.0	40.0	110

Panel beaters pick hammer straight head, round/pointed

- Planishing hammer with a round, slightly domed face
- Fine conical face for accurate hammering out
- Work areas ground
- Special steel



	L mm	head length mm	Ø round side mm	Weight kg
140.2137	325.0	140.0	40.0	460

Aluminium bodywork fl t pick hammer curved head, round/fl t tip

- For hammering out aluminium car body panels
- Planishing hammer with a round, slightly domed face
- Fine face for accurate hammering out
- Polished surface
- Aluminium



	L mm	head length mm	Ø round side mm	Tip width mm	Weight kg
700.1490	300.0	140.0	40.0	20.0	140

Panel beaters pick hammer straight head, round/fl t point

- Planishing hammer with a round, slightly domed face
- Fine face for accurate hammering out
- Work areas ground
- Special steel



	L mm	head length mm	Ø round side mm	Tip width mm	Weight kg
140.2136	325.0	140.0	40.0	19.0	460

Panel beaters pick hammer straight head, fl t/pointed

- Planishing hammer with a round, slightly domed face
- Fine face curved for accurate hammering out
- Work areas ground
- Special steel



	L mm	head length mm	Ø round side mm	Tip width mm	Weight kg
140.2131	325.0	140.0	40.0	19.0	460

Aluminium bodywork standard hammer curved head, round/square

- For hammering out aluminium car body panels
- Simple hammer with a fl t, angular face and a round, slightly arched face
- Polished surface
- Aluminium



	L mm	head length mm	Ø round side mm	square dia mm	Weight kg
700.1491	300.0	100.0	40.0	38 x 38 mm	148

Panel beaters standard hammer curved head, large round/square

- Simple hammer with a fl t, angular face and a round, slightly arched face
- Work areas ground
- Special steel



	L mm	head length mm	Ø round side mm	square dia mm	Weight kg
140.2134	325.0	100.0	40.0	38 x 38 mm	490

Wing dinging hammer

- Ideal for hammering out the wings
- Extra heavy execution
- Fine face curved for accurate hammering out
- Safe and easy use
- Polished working surfaces
- With hickory handle
- Special steel



	Length mm	head length mm	square dia mm	Tip width mm	Weight kg
140.2461	380	220	30 x 38 mm	35	1.31

Bodywork serrated hammer

- For hammering out the bodywork area
- High-quality design
- Work area coarse
- Special steel



	Length mm	head length mm	square mm	Weight
140.2204	325.0	60.0	30 x 45 mm	330

Bodywork standard hammer, slightly curved

- For hammering out the bodywork area
- High-quality design
- Work area ground and lightly arched
- Special steel



	Length mm	head length mm	square mm	Weight
140.2209	325.0	60.0	30 x 45 mm	330

Bodywork standard hammer, sharply curved

- For hammering out the bodywork area
- High-quality design
- Work area ground and strongly arched
- Special steel



	Length mm	head length mm	square mm	Weight
140.2319	325.0	60.0	30 x 45 mm	360

Bodywork dinging hammer set

- For hammering out the car body
- High-quality design
- Optimum composition of rough and curved faces
- Polished working surfaces
- Special steel
- In durable plastic storage case



	Weight
140.2200	3 pcs Bodywork dinging hammer set

consists of:

		Weight
140.2204	Bodywork serrated hammer	330
140.2209	Bodywork standard hammer, slightly curved	330
140.2319	Bodywork standard hammer, sharply curved	360

Car body panel beating set

- For hammering out on the car body area
- High quality execution
- Includes clamping and simple tools
- Special steel



	Weight
140.2125	3 pcs Car body panel beating set

consists of:

		Weight
140.2112	Car bodywork panel beating grid toe dolly 127mm	1130
140.2132	Panel beaters hammer, serrated hammer large round/square	490
140.2133	Panel beaters hammer, standard hammer arched, round/square	420

Car body panel beating set

- For hammering out on the car body area
- Practical grouping together
- For stretching and forming of car body sheet panels
- In durable plastic storage case



	Weight
140.2100	7 pcs Car body panel beating set

consists of:

		Weight
140.2114	Car bodywork-universal slapping dolly, 70 mm	1380
140.2115	Car bodywork-pointed slapping dolly, arched and ground, 130 mm	1630
140.2116	Car bodywork-heel dolly, arched and ground, 60 mm	1130
140.2119	Car bodywork-toe dolly (large), 120 mm	1400
140.2133	Panel beaters hammer, standard hammer arched, round/square	420
140.2137	Panel beaters-pick hammer straight head, round/pointed, ground 325 mm	460
140.2139	Panel beaters-serrated hammer fine head, (round/square), ground, 325 mm	490

Rubber hammer

- DIN 5128
- With tapered ash inserted handle
- Hammer head made out of hard rubber
- With white rubber head

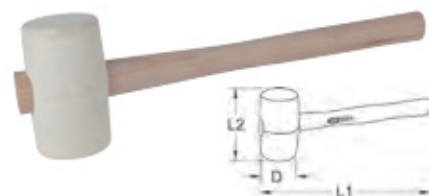

	g	D mm	L1 mm	L2 mm	Weight
140.1234	270	55.0	300.0	115.0	300
140.1235	500	60.0	340.0	115.0	595
140.1236	735	65.0	380.0	130.0	855

Rubber hammer

- DIN 5128
- With ash handle
- Hammer head made out of hard rubber



	g	D mm	L1 mm	L2 mm	handle type	Weight
140.5221	300	54.0	310.0	85.0	140.5304	140.5404
140.5222	500	60.0	320.0	100.0	140.5305	140.5405
140.5223	700	74.0	350.0	120.0	140.5306	140.5405

Rubber hammer

- DIN 5128
- With tapered ash inserted handle
- Hammer head made out of hard rubber



	g	D mm	L1 mm	L2 mm	Weight
140.1230	425	60.0	340.0	110.0	525

Rubber hammer

- DIN 5128
- With fiber lass handle
- Hammer head made out of hard rubber



	g	D mm	L1 mm	L2 mm	Weight
140.1237	500	56.0	325.0	100.0	520

Recoil free soft faced hammer

- With hickory handle
- Shock absorbing effect through steel shot in the head
- Up to 100% higher impact effect than normal Soft head hammers
- Shatterproof and wear resistant
- Polyamid heads interchangeable
- For safer working with less recoil

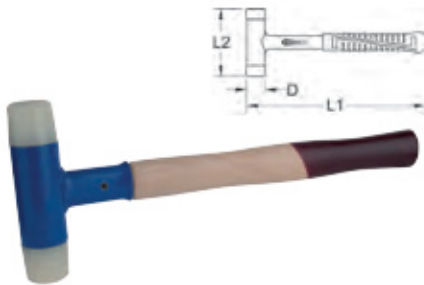

	g	D mm	L1 mm	L2 mm	handle type	⚖	👤
140.1215	350	32.0	330.0	120.0			480

Plastic hammer

- With transparent heads made from impact resistant cellulose acetate
- Impact heads are exchangeable (screw thread)
- With ash handle
- Ideal for hammering out and gentle sheet metal working



	g	D mm	L1 mm	L2 mm	handle type	⚖	👤
140.5201	200	28.0	260.0	82.0	140.5301 140.5401		210
140.5202	340	35.0	300.0	95.0	140.5304 140.5404		350

Recoil free soft faced hammer

- With steel tube handle and plastic handle
- Shock absorbing effect through steel shot in the head
- Up to 100% higher impact effect than normal Soft head hammers
- Shatterproof and wear resistant
- Polyamid heads interchangeable
- For safer working with less recoil



	g	D mm	L1 mm	L2 mm	handle type	head type	⚖	👤
140.5270	360	25.0	270.0	105.0	-	140.5280	-	360
140.5271	480	30.0	290.0	105.0	-	140.5281	-	480
140.5272	590	35.0	295.0	110.0	-	140.5282	-	590
140.5273	850	40.0	300.0	120.0	-	140.5283	-	850
140.5274	990	45.0	305.0	120.0	-	140.5284	-	990
140.5275	1110	50.0	310.0	125.0	-	140.5285	-	1110
140.5276	1290	55.0	325.0	135.0	-	140.5286	-	1290
140.5277	1670	60.0	335.0	140.0	-	140.5287	-	1670

Recoil free soft faced hammer

- With polyurethane glass-fib e composite handle
- Serrated surface for secure grip
- Free of sparks due to rubber cover
- Special absorbing effect through steel shot balls in the hammer head
- Substantially higher blow effect than in conventional hammering
- For safer working



	g	D mm	L1 mm	L2 mm	handle type	⚖	👤
140.5252	400	40.0	270.0	81.0	-	-	480
140.5254	560	40.0	305.0	100.0	-	-	640
140.5255	645	42.0	325.0	100.0	-	-	725
140.5256	860	50.0	342.0	118.0	-	-	940
140.5257	1270	56.0	355.0	118.0	-	-	1350
140.5258	1720	65.0	370.0	135.0	-	-	1800

Nylon hammer

- With impact heads made out of impact resistant nylon
- shatterproof, break and wear-resistant
- With ash handle
- Ideal for hammering out and gentle sheet metal working



	g	D mm	L1 mm	L2 mm	handle type	⚖	👤
140.5211	200	28.0	260.0	82.0	140.5301 140.5401		230
140.5212	340	35.0	300.0	95.0	140.5304 140.5404		450

Recoil free soft faced hammer, extra large

- With polyurethane glass-fib e composite handle
- Rubber handle for better grip
- Special absorbing effect through steel shot balls in the hammer head
- Substantially higher blow effect than in conventional hammering
- For safer working

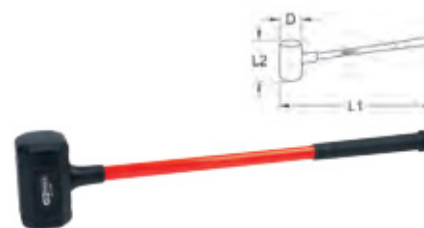

	g	D mm	L1 mm	L2 mm	handle type	⚖	👤
140.5259	4500	105.0	890.0	180.0	-	-	4.76
140.5260	5000	105.0	900.0	200.0	-	-	5.26

3 in 1 Heel dolly

- With a round form, a tip and anvil form
- Ideal for beating out bumps and dents
- With arched and ground work surfaces
- Polished surface
- Steel



	B mm	H mm	L mm	👤
140.2105	37.0	74.0	61.5	285
140.2106	37.0	86.5	39.5	394
140.2107	42.0	74.0	98.5	590

3 in 1 Heel dolly set

- Each tool with 1 x round form, 1 x tip and 1 x anvil form
- Ideal for beating out bumps and dents
- With arched and ground work surfaces
- Each form provided in different sizes
- For working in hard to access areas
- Steel



	👤
140.2108	3 pcs 3 in 1 Heel dolly set

consists of:

	👤
140.2105	3 in 1 heel dolly, 37 x 74 mm
140.2106	3 in 1 heel dolly, 37 x 86.5 mm
140.2107	3 in 1 heel dolly, 42 x 98.5 mm

Bodywork drip moulding spoon

- With blue lacquered handle
- Work areas ground and polished
- Special steel



	L mm	B mm	👤
140.2151	240.0	45.0	1.07

Bodywork slapping spoon

- With blue lacquered handle
- Work areas ground and polished
- Light execution
- Special steel



	L mm	B mm	kg
140.2150	250.0	50.0	290

Dent tool, wide

- Suitable for bodywork work
- Wide shape
- Robust design
- Special steel



	Length mm	Width mm	kg
156.0520	290.0	50.0	840

Bodywork grid toe dolly

- Arched work area
- For stretching with grooved surface
- Grooved surface has red lacquer
- Polished surface



	L mm	B mm	kg
140.2112	120.0	58.0	1.13

Dent tool

- Suitable for bodywork work
- Wide shape
- Robust design
- Special steel



	Length mm	Width mm	kg
156.0507	420.0	60.0	1.82

Dent tool, long

- Suitable for bodywork work
- Wide and long form
- Robust design
- Special steel



	Length mm	Width mm	kg
156.0529	390.0	55.0	1.26

Aluminium bodywork comma heel dolly

- For hammering out aluminium car body panels
- Upper areas arched and ground on all sides
- Universal usage
- Polished surface
- Aluminium



	L mm	B mm	kg
140.2477	135.0	60.0	350

Panel beating pry bar

- Suitable for bodywork work
- Wide, cranked form
- Robust design
- Special steel



	Length mm	Width mm	kg
156.0506	520.0	60.0	2.24

Bodywork slapping heel dolly

- With fl t, arched and ground work areas
- Polished surface



	L mm	B mm	kg
140.2110	105.0	60.0	670

Bodywork curved heel dolly

- Upper areas on all sides arched and ground
- Polished surface



	L mm	B mm	kg
140.2115	130.0	59.0	1.63

Dent tool, narrow

- Suitable for bodywork work
- Narrow form
- Robust design
- Special steel



	Length mm	Width mm	kg
156.0519	270.0	30.0	620

Bodywork toe dolly, small

- With fl t, arched and ground work areas
- Polished surface
- Narrow execution



	L mm	B mm	kg
140.2111	115.0	55.0	960

Aluminium bodywork recess heel dolly

- For hammering out aluminium car body panels
- Upper areas arched and ground on all sides
- Universal usage
- Polished surface
- Aluminium



	L mm	B mm	kg
140.2476	75.0	30.0	186

Bodywork heel dolly

- Upper areas on all sides arched and ground



	L mm	B mm	kg
140.2116	60.0	80.0	1.13

Bodywork ambos heel dolly

- Work areas arched and ground
- Polished surface



	L mm	B mm	Handle mm	kg
140.2117	130.0	65.0	120.0	3.66

Bodywork small anvil heel dolly

- Work areas arched and ground
- Polished surface



	L mm	Head Ø mm	kg
140.2103	125.0	54.0	750

Body work large anvil heel dolly

- Work areas arched and ground
- Polished surface



	L mm	kg
140.2104	125.0	1.20

Bodywork dome dolly with handle

- With slightly arched and ground work areas
- Polished surface



	L mm	B mm	kg
140.2118	60.0	80.0	1.47

Aluminium bodywork toe heel dolly

- For hammering out aluminium car body panels
- Upper areas arched and ground on all sides
- Universal usage
- Polished surface
- Aluminium



	L mm	B mm	kg
140.2479	102.0	58.0	265

Bodywork toe dolly, large

- With fl t, arched and ground work areas
- Polished surface



	L mm	B mm	kg
140.2119	120.0	58.0	1.40

Bodywork outline dolly

- With fl t, arched and ground work areas
- Polished surface



	L mm	B mm	kg
140.2120	120.0	58.0	1.63

Bodywork double dolly

- In anvil form
- With arched and ground work surfaces
- Polished surface



	L mm	B mm	kg
140.2113	59.5	53.0	1.38

Aluminium bodywork universal heel dolly

- For hammering out aluminium car body panels
- In hand fi t form
- With arched and ground work surfaces
- Universal usage
- Polished surface
- Aluminium



	L mm	H mm	kg
140.2478	70.0	65.0	210

Bodywork universal heel dolly

- In hand fi t form
- With arched and ground work surfaces
- Universal usage
- Polished surface



	L mm	H mm	kg
140.2114	70.0	85.0	1.38

Bodywork anvil dolly

- Diabolo-shaped
- Polished surface



	Ø mm	Height mm	kg
140.2101	55.0	55.0	740

Bodywork anvil dolly wedge

- Wedge-shaped
- Polished surface



	Length mm	Width mm	Height mm	Weight kg
140.2102	111.0	62.0	27.0	840

Fold alignment tool

- Suitable for aligning bodywork panels
- Important registering tool
- Groove for lateral alignment
- Extremely durable
- Special plastic

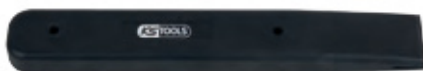

	L mm	B mm	Weight kg
140.2141	270.0	40.0	180



Handling tool, semi-circular

- Suitable for aligning bodywork panels
- Precise handling of profile panels
- Aligning curves
- Extremely durable
- Special plastic



	L mm	B mm	Weight kg
140.2142	280.0	90.0	220

Round anvil

- Ideal for aligning bodywork panels
- Stable tip
- Simple handling
- Robust design
- Extremely durable
- Special plastic



	L mm	Weight kg
140.2146	180.0	1.60

Anvil dolly, flat and curved

- Suitable for aligning bodywork panels
- Ideal for counter-holding
- Robust design
- Extremely durable
- Special plastic



	L mm	B mm	Weight kg
140.2163	190.0	50.0	320

Edge alignment tool

- Suitable for aligning bodywork panels
- Used for aligning edges
- Robust design
- Extremely durable
- Special plastic



	L mm	B mm	Weight kg
140.2149	280.0	100.0	200

Profile alignment block

- Suitable for aligning bodywork panels
- For angled contours
- For large areas
- Extremely durable
- Special plastic



	L mm	B mm	Weight kg
140.2144	360.0	60.0	1.28

Rubber guide wedge, small

- Suitable for aligning bodywork panels
- Optimal resistance
- For narrow sites
- Robust design
- Special plastic



	L mm	B mm	H mm	Weight kg
140.2164	65.0	75.0	40.0	400

Rubber guide wedge, large

- Suitable for aligning bodywork panels
- Optimal resistance
- Robust design
- Special plastic



	L mm	B mm	H mm	Weight kg
140.2167	120.0	75.0	40.0	700

WING BRAKE PIPE FLARING

Universal wing flange tool

- Ideal for expanding the wing
- Suitable for 4 and 5-hole wheel hubs
- Extremely gentle on paintwork
- Secure and easy to use
- Special steel



	Length mm	Width mm	Height mm	Weight kg
140.2096	440.0	150.0	260.0	6.88

BODYWORK FILES

Bodywork fill

- With a handle for safe one handed usage
- For fl t applications
- Double sided blade
- Includes a blade
- With two component handle
- Special steel



	Out	Length mm	Width mm	File code	Weight
140.3010	1	Single cut	490.0	35.0	140.3013 640
140.3011	1	Cross cut	490.0	35.0	140.3014 640
140.3012	3	Cross cut	490.0	35.0	140.3015 640

Bodywork file blade holde

- With a handle and knob for safe two handed usage
- For fl t applications
- Suitable for file blad ; radial and helical toothing
- Made out of wood



	Length mm	Width mm	Weight
140.3016	525.0	25.0	350

Bodywork file blad

- DIN 7264 Form A
- sides
- Milled, helical toothing
- Suitable for bodywork file blade holder 14 .3016



	Length mm	Width mm	Weight
161.0017	350.0	35.0	250
161.0018	350.0	35.0	250
161.0019	350.0	35.0	250

Bodywork file blad

- DIN 7264 Form A
- sides
- Milled, radial toothing
- Suitable for bodywork file blade holder 14 .3016



	Length mm	Width mm	Weight
161.0021	350.0	35.0	262
161.0022	350.0	35.0	262

Bodywork file blade holde

- With a handle and knob for safe two handed usage
- For semi-circular applications
- Suitable for file blad ; semi-circular (hollow)
- Made out of wood

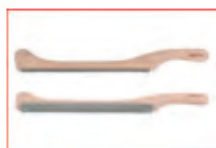

	Length mm	Width mm	Weight
140.3017	525.0	25.0	277

Bodywork file blad

- DIN 7264 Form F
- Semi-circular (hollow)
- Semi-circular, radial toothing
- Suitable for bodywork file blade holder 14 .3017



	Length mm	Width mm	Weight
161.0023	350.0	30.0	250

Bodywork fill , adjustable

- With a handle and knob for safe two handed usage
- For fl t and curved applications
- Double sided blade
- Includes one blade - radius 10 teeth
- Aluminium



	Length mm	Width mm	Replacement holder	Replacement blade	Weight
140.3090	350.0	34.0	140.3091	140.3092	770

Flexible sanding paper holder with rubber mat

- With quick clamping system for holding the sanding paper
- Rubber mat ensures a firm s ating of the sanding paper
- Extremely fl xible
- Adapts itself to the bodywork
- Ergonomic wooden handles

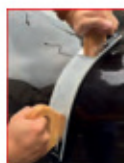

	Length mm	Width mm	Weight
140.3019	400.0	70.0	440

HOLE, SETTING, AND SEAM PLIERS

Seaming pliers

- For folding of sheet metal
- Straight design
- Insulated handle
- Cast iron



	L mm	B mm	Weight
222.1601	280.0	52.0	660

Seaming pliers

- For folding of sheet metal
- 45° angled jaws
- Insulated handle
- Cast iron

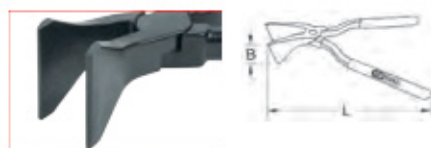

	L mm	B mm	Weight
222.1602	260.0	52.0	670

Seaming pliers

- For folding of sheet metal
- 90° angled jaws
- Insulated handle
- Cast iron

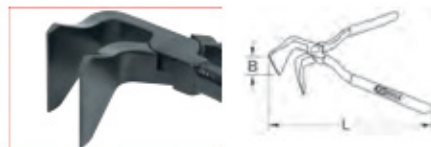

	L mm	B mm	Weight
222.1603	260.0	52.0	760

Mini jogger pliers

- Self opening
- For the flanging of sheet metal and body parts
- Up to 1 mm thickness
- Particularly suitable for thin sheet metal edges, curves and arches
- Requires light expenditure of energy
- Hardened flanging jaws
- Special tool steel

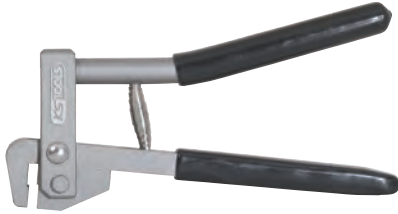
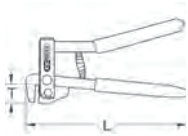

	L mm	T mm	kg
118.0056	220,0	13,0	900

Joggler pliers

- Self opening
- For the flanging of sheet metal and body parts
- Up to 1 mm thickness
- Requires light expenditure of energy
- Hardened flanging jaws
- Special tool steel

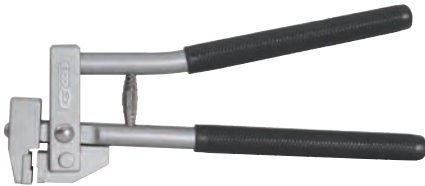
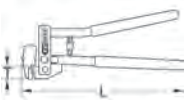

	L mm	T mm	kg
118.0058	280,0	13,0	1,00

Joggler pliers

- Self opening
- For punching straight and bent sheet metal
- Up to 1.25 mm thickness
- Radius to 40,0 mm
- Hole diameter 5 mm
- Requires light expenditure of energy
- Special tool steel

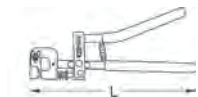

	L mm	hole diameter	kg
118.0057	300,0	max. 5 mm	1,00

Punched hole and jogger pliers

- Self opening
- Fast conversion by simply turning the head
- For the flanging and punching sheet metal and body parts
- Punching up to 1,25 mm thickness
- Hole diameter 5 mm
- Requires light expenditure of energy
- Special tool steel

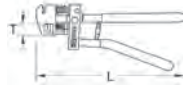

	L mm	T mm	hole diameter	kg
118.0055	285,0	13,0	max. 5 mm	1,23

Punch pliers set

- Ideal for use in all sheet-metal processing areas
- Enormous punch force due to lever mechanism
- Work depth adjustable up to 47 mm
- 7 different punches with counter tool (2,38 mm-7,14 mm)
- Easy reconstruction
- PVC dipped handle
- Plier body from die-cast metal
- In durable plastic storage case

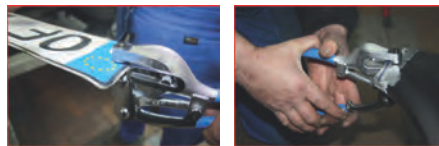

	kg
118.0105 16 pcs. Punch pliers set	1,33

consists of:

	kg
118.0106 Joggler pliers	1020
118.0107 Punch, 2,38 mm	10
118.0108 Punch, 3,18 mm	10
118.0109 Punch, 3,97 mm	10
118.0110 Punch, 4,76 mm	10
118.0111 Punch, 5,56 mm	10
118.0112 Punch, 6,35 mm	10
118.0113 Punch, 7,14 mm	10
118.0114 Counter holder, 2,38 mm	5
118.0115 Counter holder, 3,18 mm	5
118.0116 Counter holder, 3,97 mm	5
118.0117 Counter holder, 4,76 mm	5
118.0121 Counter holder, 5,56 mm	5
118.0122 Counter holder, 6,35 mm	5
118.0123 Counter holder, 7,14 mm	5
118.0126 Assembly tool	11

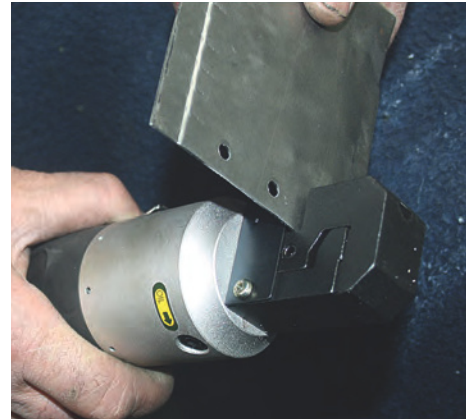

Pneumatic hole and jogger pliers

- Self-opening
- For the flanging and punching sheet metal and body parts
- Flanging and punching up to a maximum material thickness of 1.5 mm
- Hole diameter 5 mm
- Lower power usage
- Rubber handle
- Special tool steel



Technical data:

Rebate width:	22 mm
Rebate depth:	12 mm
Air consumption:	113 l/min
Operating pressure:	6,3 bar (90 psi)
Min. tube diameter:	3/8" - 10 mm
Connection thread:	1/4"

	Length mm	Ø mm	kg
515.1295	250,0	55,0	1,30

SHEET METAL NIBBLER AND SNIPS

Sheet steel nibbler

- Burr free cutting
- No deformation of the sheet metal
- Clean cut on the edges
- Easy locking action
- PVC dipped handle
- Cuts sheet metal up to 1.2 mm ideal also for aluminum, copper and plastic
- Special tool steel



	Ø mm	B mm	L mm	S mm	Replacement blades	kg
140.2175	1,2	14,0	265,0	3,0	140.2175-1	460

Pneumatic nibbler

- 90° offset execution
- Air exhaust through the handle rear end
- For one handed operation with ergonomic design
- Ideal for curved and straight cutting
- Cut is made by punching a series of holes sequentially in sheet metal
- Also suitable for plastic cutting
- For extremely small radius
- With stepless speed regulation
- Vibration dampened
- Cold insulated handle
- Includes 1/4" coupling connector
- Ultra light robust housing special plastic

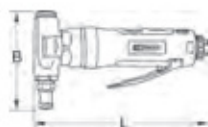

Technical data:

Cutting speed: 2,6 m/min
 Cutting output: steel 1,2 mm
 Aluminium 1,6 mm
 Cutting width: 4,5 mm
 Capacity: 330 Watt
 Vibration: < 0,5 ms²
 Noise performance level: 95 dbA
 Noise pressure level: 82 dbA
 Air consumption: 85 l/min
 Operating pressure: max. 6,3 bar (90 psi)
 Min. tube diameter: 3/8" - 10 mm
 Connection thread: 1/4"PT

	B mm	L mm	S mm
515.3050	100.0	190.0	1.15

Ideal shears

- Straight cut
- With spring
- Induction-hardened precision cutting
- With PVC dipped handle
- Cuts steel sheet up to 1.2 mm, stainless steel up to 0.7 mm
- Special tool steel



	Ø mm	L mm	S mm	W
118.0145	1,2 (0,7)	280,0	38,0	630

Tin snips, left handed cut

- Left handed cut
- With spring
- Induction-hardened precision cutting
- With PVC dipped handle
- Cuts steel sheet up to 1,2 mm, stainless steel up to 0,7 mm
- Special tool steel

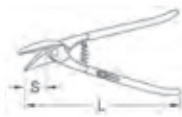

	Ø mm	L mm	S mm	W
118.0146	1,2 (0,7)	280,0	38,0	540

Punching shears

- Induction-hardened precision cutting
- With PVC dipped handle
- Cuts steel sheet up to 1.2 mm, stainless steel up to 0.7 mm
- Special tool steel

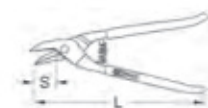

	Ø mm	L mm	S mm	W
118.0147	1,2 (0,7)	250,0	42	455

Punching scissors, left handed cut

- Left handed cut
- Induction-hardened precision cutting
- With PVC dipped handle
- Cuts steel sheet up to 1,2 mm, stainless steel up to 0,7 mm
- Special tool steel

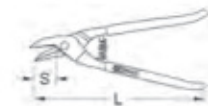

	Ø mm	L mm	S mm	W
118.0148	1,2 (0,7)	250,0	42	455

Pelican straight cut shears

- Right hand cutting
- Straight cut
- With spring
- Induction-hardened precision cutting
- With PVC dipped handle
- Cuts steel sheet up to 1.2 mm, stainless steel up to 0.7 mm
- Special tool steel



	Ø mm	L mm	S mm	W
118.0149	1,2 (0,7)	305,0	73,5	465

Mini metal shears, straight cut

- Straight cut
- Optimal for fine working
- Self opening handle
- With internal spring
- With easy locking action
- Induction-hardened precision cutting
- With two component handle
- Cuts sheet metal up to 1.2 mm
- Special tool steel



	Ø mm	A mm	D mm	L mm	S mm	W
118.0152	1,2	10,0	20,0	180,0	20,0	300

Mini metal shears, right handed cut

- Right handed cut
- Optimal for fine working
- Self opening handle
- With internal spring
- With easy locking action
- Induction-hardened precision cutting
- With two component handle
- Cuts sheet metal up to 1.2 mm
- Special tool steel

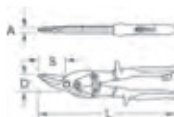

	Ø mm	A mm	D mm	L mm	S mm	W
118.0151	1,2	17,0	33,0	180,0	20,0	300

Mini metal shears, left handed cut

- Left handed cut
- Optimal for fine working
- Self opening handle
- With internal spring
- With easy locking action
- Induction-hardened precision cutting
- With two component handle
- Cuts sheet metal up to 1.2 mm
- Special tool steel

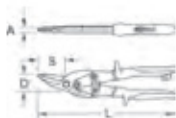

	Ø mm	A mm	D mm	L mm	S mm	Wt g
118.0153	1,2	20,0	25,0	190,0	20,0	300

Mini straight and shape cutting snip set

- Self opening handle
- With internal spring
- With easy locking action
- With two component handle
- 25% power savings
- Left, right hand cutting & straight
- Smooth blades
- Induction-hardened precision cutting
- Cuts sheet metal up to 1.2 mm
- Chrome molybdenum



	Ø mm	A mm	D mm	L mm	S mm	Wt g
118.0150	3 pcs	Mini straight and shape cutting snip set				800

Tin snips sheet metal shear, self opening, straight cut

- Straight cut
- Self opening handle
- Serrated blades
- Internal spring
- Easy locking action
- Includes hanging loop
- Induction hardened precision cutting
- Two component handle
- Cuts steel sheet up to 1.2 mm, stainless steel up to 0,7 mm
- Special tool steel

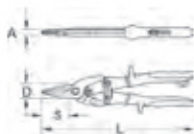

	Ø mm	A mm	D mm	L mm	S mm	Wt g
118.0051	1,2 (0,7)	20,0	19,0	250,0	45,0	400

Tin snips sheet metal shear, self opening, right handed cut

- Right handed cut
- Self opening handle
- Serrated blades
- Internal spring
- Easy locking action
- Includes hanging loop
- Induction hardened precision cutting
- Two component handle
- Cuts steel sheet up to 1,2 mm, stainless steel up to 0,7 mm
- Special tool steel

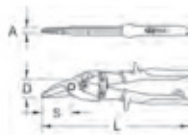

	Ø mm	A mm	D mm	L mm	S mm	Wt g
118.0052	1,2 (0,7)	18,0	21,0	240,0	42,0	400

Tin snips sheet metal shear, self opening, left handed cut

- Left handed cut
- Self opening handle
- Serrated blades
- Internal spring
- Easy locking action
- Includes hanging loop
- Induction hardened precision cutting
- Two component handle
- Cuts steel sheet up to 1,2 mm, stainless steel up to 0,7 mm
- Special tool steel

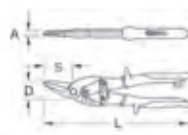

	Ø mm	A mm	D mm	L mm	S mm	Wt g
118.0053	1,2 (0,7)	17,0	26,0	240,0	44,0	400

Tin snips sheet metal shear set

- Self opening handle
- Serrated blades
- Internal spring
- Easy locking action
- Includes hanging loop
- Induction hardened precision cutting
- Two component handle
- Cuts steel sheet up to 1.2 mm, stainless steel up to 0,7 mm
- Special tool steel



	Ø mm	A mm	D mm	L mm	S mm	Wt g
118.0050	3 pcs	Tin snips sheet metal shear set				1,20

Template cutting shear with lever gearing, right handed cut

- Right handed cut
- Self opening handle
- Serrated blades
- With internal spring
- With easy locking action
- Includes hanging loop
- Induction hardened precision cutting
- With two component handle
- Cuts steel sheet up to 1.5 mm, stainless steel up to 1.0 mm
- Special tool steel

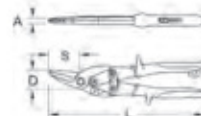

	Ø mm	A mm	D mm	L mm	S mm	Wt g	
118.0045	right	1,5 (1,0)	30,0	50,0	260,0	40,0	380

Template cutting shear with lever gearing, left handed cut

- Left handed cut
- Self opening handle
- Serrated blades
- With internal spring
- With easy locking action
- Includes hanging loop
- Induction hardened precision cutting
- With two component handle
- Cuts steel sheet up to 1.5 mm, stainless steel up to 1.0 mm
- Special tool steel



	Ø mm	A mm	D mm	L mm	S mm	Wt g	
118.0046	left	1,5 (1,0)	30,0	50,0	260,0	40,0	380

Manual guillotine shears

- Ideal for all straight and round cuts
- Cuts practically all materials up to 1.5 mm
- Easy cutting of external and internal radii, contours, curves, angles, etc.
- No deformation of the material
- Simple cutting of long, straight work pieces
- approx. 190 mm cutting lengths
- Self-sharpening due to special blade, no regrinding necessary
- Includes a mount for a workbench

Application range: Steel, copper, aluminium, brass, stainless steel, etc.



	Cutting width mm	Max. material strength mm	Wt g
118.0144	250,0	1,5	4,50

Pneumatic sheet metal shear

- Air exhaust through the handle rear end
- For one handed operation with ergonomic design
- Ideal for the cutting of car body sheet metal and aluminium sheet
- Eccentric cutting drive
- For curved cutting up to 100 mm radius
- With stepless speed regulation
- Number of revolutions adjustable through regulating screw
- Vibration dampened
- Cold insulated handle
- Includes 1/4" coupling connector
- Ultra light robust housing special plastic



Technical data:

Cutting speed:	2,6 m/min
Cutting output:	steel 1,2 mm Aluminium 1,6 mm
Cutting width:	5,0 mm
Vibration:	< 9,1 ms ²
Noise performance level:	95 dbA
Noise pressure level:	82 dbA
Air consumption:	85 l/min
Operating pressure:	max. 6,3 bar (90 psi)
Min. tube diameter:	3/8" - 10 mm
Connection thread:	1/4"PT

	B mm	L mm		
515.3055	59.0	250.0	515.3055-40	1.25

PANEL SAWS

SlimPOWER mini-pneumatic reciprocating bodywork key hole saw

- Air exhaust through the used air tube to the rear
- For one handed operation
- For works in car body panels, beams and profil
- Secure operation lever with locking device
- Suitable for small sawing radius
- Stepless speed regulation
- Vibration dampened
- Includes 1/4" coupling connector
- Robust metal housing



Technical data:

Stroke:	7,9 mm
Cutting strokes:	5760 strokes/min
Capacity:	190 Watt
Vibration:	< 16,4 ms ²
Noise pressure level:	92 dbA
Noise performance level:	81,0 dbA
Air consumption:	240.66 l/min
Operating pressure:	max. 5,5 bar (80 psi)
Min. tube diameter:	4,8 mm
Connection thread:	1/4"

	B mm	L mm		
515.5045	36.0	170.0	129.3740-46	500

Pneumatic reciprocating bodywork saw, low vibration

- Air exhaust through the used air tube to the rear
- For one handed operation with ergonomic design
- For works in car body panels, beams and profil
- Secure operation lever with locking device
- Suitable for small sawing radius
- Stepless speed regulation
- Number of revolutions adjustable through regulating screw
- Vibration dampened
- Cold insulated handle
- Includes 1/4" coupling connector
- Robust metal housing

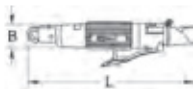

Technical data:

Stroke:	10,0 mm
Cutting strokes:	5760 strokes/min
Vibration:	< 9,1 ms ²
Noise pressure level:	69,2 dbA
Noise performance level:	81,0 dbA
Air consumption:	196 l/min
Operating pressure:	max. 6,3 bar (90 psi)
Min. tube diameter:	3/8" - 10 mm
Connection thread:	1/4"PT

	B mm	L mm		
515.3000	45.0	790.0	129.3740-46	800

Jigsaw blades

- Flexible and shatter proof
- Suitable for:
- Non ferrous metal and stainless steel
- Steel sheet and car body panels
- Compression moulded material and formica

Suitable for: Ober, KS, Pneutec, CP, KS 515.3000 und 515.3200



	No. teeth	TN	D mm	L mm	Contour	
129.3740	80	32	1,0	100,0	5	30
129.3742	60	24	1,0	100,0	5	30
129.3744	45	18	1,0	100,0	5	30
129.3746	35	14	2,0	100,0	5	30

Jigsaw blades

- Flexible and shatter proof
- Suitable for:
- Non ferrous metal and stainless steel
- Steel sheet and car body panels
- Compression moulded material and formica

Suitable for: SIG und Flex



	No. teeth	TN	D mm	L mm	Contour	
129.3750	80	32	0,7	100,0	5	20
129.3752	60	24	1,0	100,0	5	20
129.3754	45	18	1,4	100,0	5	20
129.3756	35	14	1,8	100,0	5	20

LOCKING PLIERS

Mini welding clamp set

- Ideal for preparing bodywork welding work
- Adjustable clamping range for various panel thicknesses
- Can be used in the narrowest of spaces, e.g. wheel arches, window apertures, engine compartment, etc.
- With tiltable clamp jaws
- Contact pressure adjustable via wing nut
- Span width 0 – 7 mm
- Allows for precise adjusting and positioning



115.1105	4 pcs Mini welding clamp set	315

consists of:

	X	
115.1106	4 Mini welding clamp	78

Micro grip pliers

- Ideal for confined areas
- Straight linear design of the movable jaw
- With brass screw for fine adjustment
- With loosening lever for lever lock clamping
- Suitable for aluminium repairs
- resistant to welding spatter
- One hand operation
- Aluminium alloy

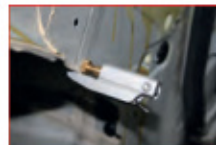

	Clamping range mm	Length mm	
115.1026	0 - 12,0 mm	92,0	120

Locking pliers holder

- Alternative for a vice
- For light work
- For screwing onto workbenches, worktables etc.



	L mm	B mm	T mm	
115.2072	91,0	84,0	24,3	300

Locking pliers

- Forged gripping jaws
- Serrated execution
- Size adjustment using the adjustment wheel
- With loosening lever
- With easy locking action
- For round and flat material
- To hold when welding
- No flaring under the strongest loads
- Loosening under continuous pressure of a spring
- Nickel plated
- Chrome vanadium

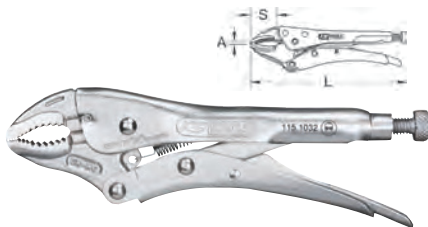

	A mm	L mm	S mm	W
115.1031	0-50	140,0	19,3	180
115.1032	0-55	175,0	24,0	340
115.1033	0-60	220,0	27,5	520

Wide jaw locking pliers

- Forged gripping jaws
- Serrated execution
- Size adjustment using the adjustment wheel
- With loosening lever
- With easy locking action
- For round and flat material
- To hold when welding
- No flaring under the strongest loads
- Loosening under continuous pressure of a spring
- Nickel plated
- Chrome molybdenum

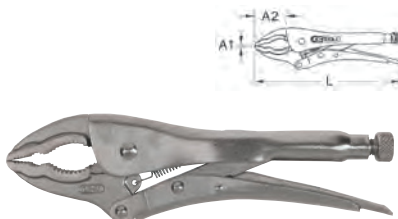

	A mm	L mm	S mm	W
115.1506	0-64	235,0	50,0	600

Locking pliers with quick-release lever, straight jaws

- Forged gripping jaws
- Serrated execution
- Size adjustment using the adjustment wheel
- With easy locking action
- For round and flat material
- To hold when welding
- With quick-release lever
- No flaring under the strongest loads
- Loosening under continuous pressure of a spring
- Nickel plated
- Chrome molybdenum
- With dual component handle



	A mm	L mm	S mm	W
115.3011	0-40	175,0	25,0	400
115.3012	0-50	250,0	30,0	600

Power locking pliers

- Forged gripping jaws
- Prevents slipping even at high forces
- Well thought through jaw teeth
- Size adjustment using the adjustment wheel
- With loosening lever
- With easy locking action
- For round and flat material
- To hold when welding
- No flaring under the strongest loads
- Loosening under continuous pressure of a spring
- Nickel plated
- Chrome vanadium



	A mm	L mm	S mm	W
115.1196	0-40	175,0	30,0	400
115.1197	0-50	220,0	37,0	600

Wide jaw locking pliers with quick-release lever

- Forged gripping jaws
- Serrated execution
- Size adjustment using the adjustment wheel
- With easy locking action
- For round and flat material
- To hold when welding
- With quick-release lever
- No flaring under the strongest loads
- Loosening under continuous pressure of a spring
- Nickel plated
- Chrome molybdenum
- With dual component handle



	A mm	L mm	S mm	W
115.2006	0-65	230,0	51,0	620

Locking pliers, V jaws

- Forged gripping jaws
- Serrated execution
- Size adjustment using the adjustment wheel
- With loosening lever
- With easy locking action
- For round and flat material
- To hold when welding
- No flaring under the strongest loads
- Loosening under continuous pressure of a spring
- Nickel plated
- Chrome molybdenum

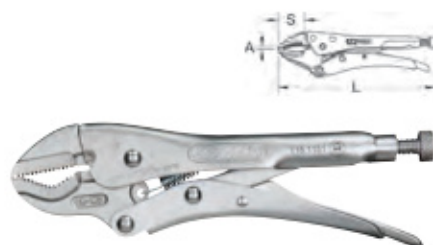

	A mm	L mm	S mm	W
115.1151	0-25	185,0	24,0	400
115.1152	0-32	225,0	27,5	600

Locking pliers with quick-release lever

- Forged gripping jaws
- Serrated execution
- Size adjustment using the adjustment wheel
- With easy locking action
- For round and flat material
- To hold when welding
- With quick-release lever
- No flaring under the strongest loads
- Loosening under continuous pressure of a spring
- Nickel plated
- Chrome molybdenum
- With dual component handle



	A mm	L mm	S mm	W
115.2031	0-30	125,0	21,0	300
115.2032	0-40	175,0	27,0	390
115.2033	0-55	225,0	30,0	600

Locking pliers, straight jaws

- Forged gripping jaws
- Serrated execution
- Size adjustment using the adjustment wheel
- With loosening lever
- With easy locking action
- For round and flat material
- To hold when welding
- No flaring under the strongest loads
- Loosening under continuous pressure of a spring
- Nickel plated
- Chrome molybdenum

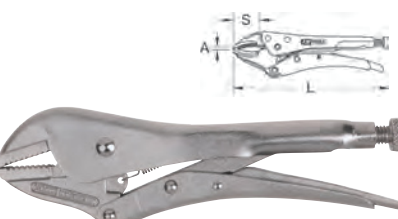

	A mm	L mm	S mm	W
115.1501	0-28,5	175,0	27,0	370
115.1502	0-45,5	225,0	30,0	600

Clamping pliers for pipes

- Forged gripping jaws
- Size adjustment using the adjustment wheel
- With loosening lever
- With easy locking action
- With hexagonal nut for safe fastening
- For clamping pipes
- No flaring under the strongest loads
- Loosening under continuous pressure of a spring
- Nickel plated
- Chrome molybdenum



	A mm	L mm	S mm	W
115.1504	0-30,5	175,0	29,5	360

Clamping pliers for pipes

- Forged gripping jaws
- Serrated execution
- Size adjustment using the adjustment wheel
- With loosening lever
- With easy locking action
- For clamping pipes
- No flaring under the strongest loads
- Loosening under continuous pressure of a spring
- Nickel plated
- Chrome molybdenum



	A mm	L mm	S mm	Wt. kg
115.1505	0-86	255.0	118.0	500

Round jaw locking pliers with wire cutter

- For safe gripping of nuts and screw heads
- 3 level points prevents slipping and rounding
- With loosening lever
- With easy locking action
- Size adjustment using the adjustment wheel
- Good adaptation to existing surfaces
- With wire cutting function
- No flaring under the strongest loads
- Loosening under continuous pressure of a spring
- Nickel plated
- Chrome molybdenum



	Wt. kg	L mm	Wt. kg
115.1175	11-19	175.0	370
115.1176	16-27	240.0	700

Chain grip pliers

- For fastening and clamping of different profiles
- With loosening lever
- With easy locking action
- Size adjustment using the adjustment wheel
- Ideal for confined spaces
- Good adaptation to existing surfaces
- No flaring under the strongest loads
- Loosening under continuous pressure of a spring
- Nickel plated
- Chrome molybdenum



	Ø mm	L mm	Replacement chain	Wt. kg
115.1171	150.0	220.0	115.1172	755

Long nose locking pliers

- Forged gripping jaws
- Serrated execution
- Size adjustment using the adjustment wheel
- With loosening lever
- With easy locking action
- For round and flat material
- To hold when welding
- No flaring under the strongest loads
- Loosening under continuous pressure of a spring
- Nickel plated
- Chrome molybdenum

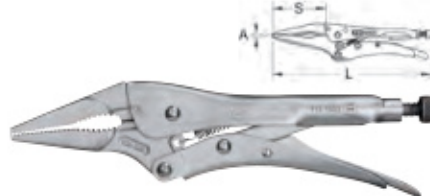

	A mm	L mm	S mm	Wt. kg
115.1177	0-25	125.0	35	110
115.1034	0-35	150.0	45.0	180
115.1035	0-45	210.0	65.0	340

Long-nose locking pliers with quick-release lever

- Forged gripping jaws
- Serrated execution
- Size adjustment using the adjustment wheel
- With easy locking action
- For round and flat material
- To hold when welding
- With quick-release lever
- No flaring under the strongest loads
- Loosening under continuous pressure of a spring
- Nickel plated
- Chrome molybdenum
- With dual component handle



	A mm	L mm	S mm	Wt. kg
115.2034	0-45	170.0	45.0	300
115.2035	0-60	205.0	53.0	500

Wide and flat jaw locking pliers

- Forged gripping jaws
- With loosening lever
- With easy locking action
- Size adjustment using the adjustment wheel
- For clamping of flat or bended metal sheets
- No flaring under the strongest loads
- Loosening under continuous pressure of a spring
- Nickel plated
- Chrome molybdenum



	A mm	B mm	C mm	L mm	Wt. kg
115.1076	0-53	90.0	40.0	205.0	480
115.1077	0-57	100.0	45.0	245.0	650

Wide jaw flat die locking pliers with quick-release lever

- Forged gripping jaws
- With easy locking action
- Size adjustment using the adjustment wheel
- For clamping of flat or bended metal sheets
- With quick-release lever
- No flaring under the strongest loads
- Loosening under continuous pressure of a spring
- Nickel plated
- Chrome molybdenum
- With dual component handle



	A mm	C mm	L mm	B mm	Wt. kg
115.2076	0-40	45.0	205.0	80.0	600
115.2077	0-55	45.0	250.0	80.0	800

Welding gripping pliers

- With malleable cast iron jaws
- Suitable for setting the welding points between the cut outs
- With loosening lever
- Size adjustment using the adjustment wheel
- To hold and adjust sheets and profiles
- With easy locking action
- No flaring under the strongest loads
- Loosening under continuous pressure of a spring
- Nickel plated
- Chrome molybdenum



	A mm	C mm	L mm	Wt. kg
115.1078	0-45	70.0	220.0	600
115.1079	0-55	70.0	260.0	780

Welding gripping pliers with quick-release lever

- With malleable cast iron jaws
- Suitable for setting the welding points between the cut outs
- Size adjustment using the adjustment wheel
- To hold and adjust sheets and profiles
- With easy locking action
- With quick-release lever
- No flaring under the strongest loads
- Loosening under continuous pressure of a spring
- Nickel plated
- Chrome vanadium
- With dual component handle



	A mm	C mm	L mm	Wt. kg
115.2078	0-45	70.0	220.0	710
115.2079	0-65	70.0	260.0	875

Welding gripping pliers

- Forged semi-circular gripping jaws
- With loosening lever
- With easy locking action
- Size adjustment using the adjustment wheel
- For profiled bul y components
- Good adaptation to existing surfaces
- No fla ing under the strongest loads
- Loosening under continuous pressure of a spring
- Nickel plated
- Chrome molybdenum



	A mm	B mm	L mm	Weight
115.1070	0-35	40.0	170.0	240

Welding gripping pliers, extra long

- Round forged gripping jaws
- With loosening lever
- With easy locking action
- Size adjustment using the adjustment wheel
- For profiled bul y components
- Large clamping depth for front and rear panels
- Good adaptation to existing surfaces
- No fla ing under the strongest loads
- Loosening under continuous pressure of a spring
- Nickel plated
- Chrome molybdenum



	A mm	B mm	L mm	Weight
115.0573	0-295	415.0	610.0	1.52

Welding gripping pliers with movable clamping jaws

- Flat gripping jaws
- Movable clamping jaws
- With quick-release lever
- With easy locking action
- Size adjustment using the adjustment wheel
- For profiled bul y components
- Good adaptation to existing surfaces
- No fla ing under the strongest loads
- Loosening under continuous pressure of a spring
- Nickel plated
- Chrome molybdenum
- With dual component handle



	A mm	B mm	L mm	Weight
115.2013	0-105	115.0	170.0	0.40
115.2014	0-420	395.0	275.0	1.00

Welding gripping pliers, extra long

- Round forged gripping jaws
- Quick-release lever
- Easy locking action
- Size adjustment using the adjustment wheel
- For profiled bul y components
- Large clamping depth for front and rear panels
- Good adaptation to existing surfaces
- No fla ing under the strongest loads
- Loosening under continuous pressure of a spring
- Nickel plated
- Chrome molybdenum



	A mm	B mm	L mm	Weight
115.1072	0-270	250.0	450.0	1.18

Welding clamp gripping pliers with quick-release lever

- Very good clamping capacity
- Round forged gripping jaws
- With quick-release lever
- With easy locking action
- Size adjustment using the adjustment wheel
- For profiled bul y components
- Good adaptation to existing surfaces
- No fla ing under the strongest loads
- Loosening under continuous pressure of a spring
- Nickel plated
- Chrome vanadium
- With dual component handle

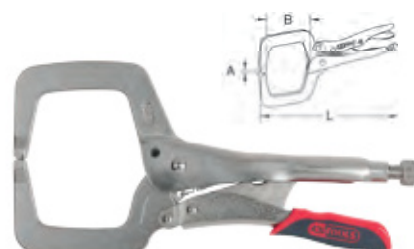

	A mm	B mm	L mm	Weight
115.2008	0-45	45.0	165.0	300
115.2009	0-90	85.0	280.0	900

Welding gripping pliers

- For applications that need a straight jaw
- Jaws from special steel
- Easy locking action
- Quick-release lever
- Size adjustment using the adjustment wheel
- Ideal for spot welding
- Nickel plated handle
- Chrome molybdenum



	A mm	C mm	L mm	Weight
115.1080	0-20	56.0	205.0	548

Welding gripping pliers

- Very good clamping capacity
- Round forged gripping jaws
- Quick-release lever
- Easy locking action
- Size adjustment using the adjustment wheel
- For profiled bul y components
- Good adaptation to existing surfaces
- No fla ing under the strongest loads
- Loosening under continuous pressure of a spring
- Nickel plated
- Chrome molybdenum

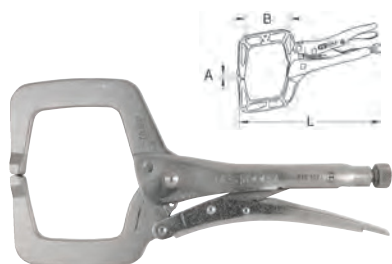

	A mm	B mm	L mm	Weight
115.1071	0-100	90.0	270.0	780

Welding gripping pliers with movable clamping jaws

- Flat gripping jaws
- Movable clamping jaws
- Quick-release lever
- Easy locking action
- Size adjustment using the adjustment wheel
- For profiled bul y components
- Good adaptation to existing surfaces
- No fla ing under the strongest loads
- Loosening under continuous pressure of a spring
- Nickel plated
- Chrome molybdenum

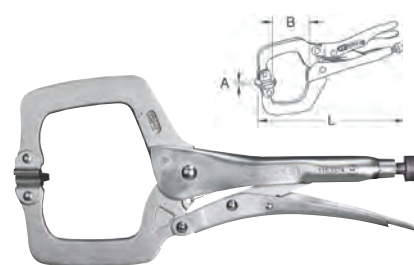

	A mm	B mm	L mm	Weight
115.1178	0-25	25.0	125.0	0.15
115.1073	0-35	40.0	170.0	0.24
115.1074	0-100	70.0	285.0	0.78
115.1075	0-270	240.0	420.0	1.25
115.0570	0-420	395.0	610.0	1.54

Welding gripping pliers

- For applications that required double curved jaws
- Jaws from special steel
- Easy locking action
- Quick-release lever
- Size adjustment using the adjustment wheel
- Ideal for fitting and mounting of body parts
- Nickel plated handle
- Chrome molybdenum

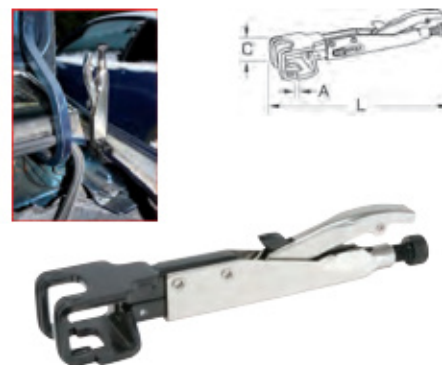

	A mm	C mm	L mm	Weight
115.1081	0-20	39.0	230.0	568

2
3
4
5
6
7
8
9
10
11
12
13
14
15
16
17
18
19
20
21
22
23
24
25
26

Welding gripping pliers

- For applications that required double curved jaws
- Jaws from special steel
- Easy locking action
- Quick-release lever
- Size adjustment using the adjustment wheel
- For welding of the hole between the panels
- Also suitable for U-profil
- Nickel plated handle
- Chrome molybdenum

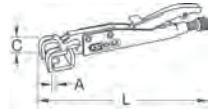

	A mm	C mm	L mm	W g
115.1082	0-15	26,0	215,0	562

Welding gripping pliers

- For applications that need a angled jaw
- Jaws from special steel
- Easy locking action
- Quick-release lever
- Size adjustment using the adjustment wheel
- Ideal for welding in the fold
- Also suitable for U-profil
- Nickel plated handle
- Chrome molybdenum



	A mm	C mm	L mm	W g
115.1083	0-20	30,0	210,0	509

Welding gripping pliers

- For applications that need a straight jaw
- Slim design
- Jaws from special steel
- Easy locking action
- Quick-release lever
- Size adjustment using the adjustment wheel
- For right-angled terminals in the fold
- For difficult to access areas
- Nickel plated handle
- Chrome molybdenum

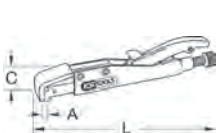

	A mm	C mm	L mm	W g
115.1084	0-16	30,0	195,0	488

Welding gripping pliers set

- For applications that need a straight jaw
- Extra slim design
- Jaws from special steel
- With easy locking action
- With quick release lever
- Size adjustment using the adjustment wheel
- For right angled terminals in the fold
- For difficult to access areas
- For welding of the hole between the panels
- Also suitable for U profil
- Ideal for spot welding
- Nickel plated handle
- Chrome molybdenum



	W g
115.1085 5 pcs Welding gripping pliers set	2.60

consists of:

	W g
115.1080 Welding gripping plier, 205mm	548
115.1081 Welding gripping plier, 230mm	568
115.1082 Welding gripping plier, 215mm	562
115.1083 Welding gripping plier, 210mm	509
115.1084 Welding gripping plier, 210mm	488

Automotive welding gripping pliers

- Forged gripping jaws
- Serrated execution
- Quick-release lever
- Easy locking action
- For flanged material
- To hold when welding
- No flaring under the strongest loads
- Loosening under continuous pressure of a spring
- Nickel plated
- Chrome molybdenum

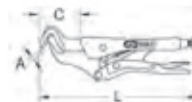

	A mm	C mm	L mm	W g
115.1068	0-40	60,0	200,0	400

Welding gripping pliers

- Flat gripping jaws
- Movable clamping jaws
- Serrated execution
- No sticking to the electrode
- Quick-release lever
- Easy locking action
- Good adaptation to existing surfaces
- Copper alloy clamping jaws
- No flaring under the strongest loads
- Loosening under continuous pressure of a spring
- Nickel plated handle
- Chrome molybdenum



	A mm	C mm	L mm	W g
115.1180	0-70	85,0	240,0	500

Locking pliers, serrated

- Forged gripping jaws
- Serrated execution
- Quick release lever
- Size adjustment using the adjustment wheel
- For round and flat material
- To hold when welding
- Nickel plated
- Chrome vanadium

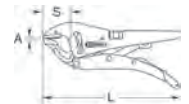

	A mm	L mm	S mm	W g
115.1036	0-55	220,0	40,0	670

Locking pliers, serrated

- Forged gripping jaws
- Serrated execution
- Quick release lever
- Size adjustment using the adjustment wheel
- For round and flat material
- To hold when welding
- Nickel plated
- Chrome vanadium

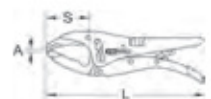

	A mm	L mm	S mm	W g
115.1037	0-85	250,0	60,0	800

Locking pliers, serrated

- Forged gripping jaws
- Movable clamping jaws
- Serrated execution
- Quick-release lever
- Size adjustment using the adjustment wheel
- For round and flat material
- To hold when welding
- Nickel plated
- Chrome vanadium



	A mm	L mm	S mm	W
115.1038	0-85	250.0	60.0	800

Automatic locking pliers

- Forged gripping jaws
- Automatic adjustment by cam mechanism
- Serrated execution
- Quick-release lever
- For round and flat material
- Heavy but controlled clamping
- To hold when welding
- Knurled handle
- Nickel plated
- Chrome vanadium



	A mm	L mm	S mm	W
115.1150	0-32	170.0	22.0	250
115.1155	0-47	250.0	29.0	620

Automatic long nosed locking pliers

- Forged gripping jaws
- Automatic adjustment by cam mechanism
- Serrated execution
- Quick-release lever
- Heavy but controlled clamping
- For round and flat material
- To hold when welding
- Knurled handle
- Nickel plated
- Chrome molybdenum

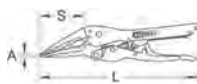

	A mm	L mm	S mm	W
115.1160	0-51	200.0	55.0	260

Automatic gripping pliers

- Flat gripping jaws
- Movable clamping jaws
- Automatic adjustment by cam mechanism
- Quick-release lever
- Heavy but controlled clamping
- For round and flat material
- For profiled body components
- Good adaptation to existing surfaces
- Knurled handle
- Nickel plated
- Chrome molybdenum

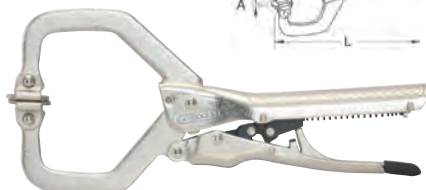
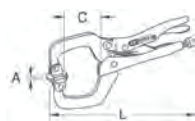

	A mm	C mm	L mm	W
115.1165	0-68	55.0	215.0	330
115.1170	0-90	90.0	310.0	860

BLIND RIVET TOOLS

Plastic rivet pliers set included rivets

- Suitable for plastic rivets
- Narrow head pliers
- Can be used in hard to access areas
- 90° angled rivet head
- With rubber grip
- Includes 40 plastic rivets
- Die-cast metal body

Plastic rivets: 5.0x15.8 - 5.0x17.2 - 6.3x25.2 - 6.6x17.2 mm



	W
150.9650 41 pcs Plastic rivet pliers set included rivets	760

consists of:

	W
150.9651 Plastic rivet pliers	580
150.9652 Replacement rivets Pack of 10, 17.2 x 6.6 mm	20
150.9653 Replacement rivets Pack of 10, 25.2 x 6.3 mm	22
150.9654 Replacement rivets Pack of 10, 17.2 x 5 mm	15
150.9655 Replacement rivets Pack of 10, 15.8 x 5 mm	16



Standard hand riveting tool

- Suitable for blind rivets
- Including four interchangeable mouthpieces
- Magazine and key in the riveter body
- Narrow head pliers
- With safety lock on the handle end
- With rubber grip
- Die-cast metal body

Blind rivets: 2.4 - 3.2 - 4.0 - 4.8 mm

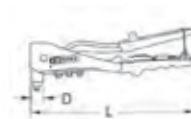

	D mm	L mm	W
150.9510	21.0	270.0	920

Standard hand riveting tool set

- Suitable for blind rivets
- Four interchangeable mouthpieces
- Magazine and key in the riveter body
- Includes 200 blind rivets
- With rubber grip
- Die-cast metal body

Blind rivets: 2.4 - 3.2 - 4.0 - 4.8 mm



	W
150.9520 205 pcs Standard hand riveting tool set	1,25

Hand rivet tool

- Suitable for blind rivets
- 360° rotating head
- For difficult to access areas
- Narrow head pliers
- With safety lock on the handle end
- Including four interchangeable mouthpieces
- Die-cast metal body

Blind rivets: 2.4 - 3.2 - 4.0 - 4.8 mm

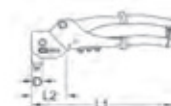

	D mm	L1 mm	L2 mm	W
150.9540	21.0	290.0	70.0	751

Universal hand rivet tool with swivel head

- Suitable for blind rivets
- 360° rotating head
- For hard-to-reach places
- Die-cast metal body

Blind rivets: 2.4mm-3.2mm-4.0mm-4.8 mm



	L mm	
150.9619	290.0	500

Universal hand riveting tool set

- Suitable for blind rivets and blind rivet nuts
- 360° rotating head
- For difficult to access areas
- Four interchangeable mouthpieces and nut rivet pulling inserts
- Die-cast metal body

Blind rivets: 2.4 - 3.2 - 4.0 - 4.8 mm
Rivet nuts: M3 - M4 - M5 - M6



150.9610 10 pcs Universal hand riveting tool set	1.96

consists of:

150.9570 Mouthpieces for riveting, 2.4 mm	10
150.9571 Mouthpieces for riveting, 3.2 mm	10
150.9572 Mouthpieces for riveting, 4.0 mm	10
150.9573 Mouthpieces for riveting, 4.8 mm	10
150.9613 Rivet nut pulling spindle for riveting tools, M3	30
150.9614 Rivet nut pulling spindle for riveting tools, M4	30
150.9615 Rivet nut pulling spindle for riveting tools, M5	30
150.9616 Rivet nut pulling spindle for riveting tools, M6	30
150.9619 Hand rivet tool 360° rotating head	500
150.9620 Rivet head for 150.9610	160

Long arm hand riveting tool

- Suitable for blind rivets
- Including four interchangeable mouthpieces
- Extra long lever arms
- High power transmission
- Magazine and key in the riveter body
- With rubber grip
- Die-cast metal body

Blind rivets: 2.4 - 3.2 - 4.0 - 4.8 mm



	D mm	L1 mm	L2 mm	
150.9530	21.0	410.0	59.0	1.50

Long-arm hand riveter set for thread sleeves

- Suitable for thread sleeves
- Including four interchangeable mandrels and mouthpieces
- Extra-long lever arms
- High power transmission
- Suitable for aluminium, steel, and stainless steel sleeves
- With rubber grip
- Die-cast metal body

Application range: for 5.0-6.0-8.0-10.0 mm thread sleeves



150.9660 10 pcs Long-arm hand riveter set for thread sleeves	1.60

consists of:

150.9661 Long arm hand riveting tool	1290
150.9662 Threaded mandrel, M5	35
150.9663 Mouthpiece, M5	32
150.9664 Threaded mandrel, M6	36
150.9665 Mouthpiece, M6	34
150.9666 Thread arbour, M8	42
150.9667 Mouthpiece, M8	33
150.9668 Thread arbour, M10	32
150.9669 Mouthpiece, M10	32
150.9670 Wrench 10 mm for threaded mandrel	12

Universal riveting tool

- Suitable for blind rivets and blind rivet nuts
- Retractable legs for increased power consumption
- Mouthpiece magazine intergrated in the handle
- With two component handle
- Die cast metal body

Blind rivets: 2.4 - 3.2 - 4.0 - 4.8 - 6.4 mm

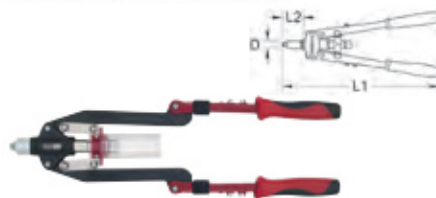

	D mm	L1 mm	L2 mm	
150.9633	30.0	510.0	45.0	1.60

Universal riveting tool set

- Suitable for blind rivets and blind rivet nuts
- Retractable legs for increased power consumption
- Mouthpiece magazine intergrated in the handle
- With two component handle
- Die-cast metal body

Blind rivets: 2.4 - 3.2 - 4.0 - 4.8 - 6.4 mm
Rivet nuts: M4 - M5 - M6 - M8 - M10



150.9630 11 pcs Universal riveting tool set	2.67

consists of:

150.9633 Universal riveter, 510 mm	1600
150.9632 Replacement rivet head for rivet tools, for 150.9630	40
150.9634 Rivet nut pulling spindle for riveting tools, M4	40
150.9635 Rivet nut pulling spindle for riveting tools, M5	40
150.9636 Rivet nut pulling spindle for riveting tools, M6	40
150.9638 Rivet nut pulling spindle for riveting tools, M8	70
150.9640 Rivet nut pulling spindle for riveting tools, M10	70
150.9642 Combination spanner 8.5 + 5.5 mm, for 150.9630	15
150.9643 Combination spanner 17 + 12 mm, for 150.9630	29
150.9644 Combination spanner 19 + 15 mm, for 150.9630	35
151.2026 Internal hexagon angled pin wrench, short, 6 mm	30

accessories:

150.9570 Rivet holders for riveting tool small and large, 2.4 mm	10
150.9571 Mouthpieces for riveting, 3.2 mm	10
150.9572 Mouthpieces for riveting, 4.0 mm	10
150.9573 Mouthpieces for riveting, 4.8 mm	10
150.9574 Mouthpieces for riveting, 5 mm	10
150.9575 Mouthpieces for riveting, 6.4 mm	10
150.9578 Replacement jaw grips suitable for rivet head, suitable for 150.9610	10
150.9579 Replacement gripping jaws for rivet head, for 150.9630	10
150.9620 Cavity wall fixing rivet head, for 150.9610	160
150.9613 Rivet nut pulling spindle for small rivet tool, M3, suitable for 150.9610	30
150.9614 Rivet nut pulling spindle for riveting tools, M4	30
150.9615 Rivet nut pulling spindle for riveting tools, M5	30
150.9616 Rivet nut pulling spindle for riveting tools, M6	30
150.9634 Rivet nut pulling spindle for riveting tools, M4	40
150.9635 Rivet nut pulling spindle for riveting tools, M5	40
150.9636 Rivet nut pulling spindle for riveting tools, M6	40
150.9638 Rivet nut pulling spindle for riveting tools, M8	70
150.9640 Rivet nut pulling spindle for riveting tools, M10	70
150.9611 Spare rivet heads, suitable for 150.9610	60
150.9631 Replacement rivet heads for rivet tools, for 150.9630	100
150.9632 Replacement rivet heads for rivet tools, for 150.9630	40

Pneumatic riveting tool pistol

- Air exhaust through the handle rear end
- For one handed operation with ergonomic design
- For pop rivet working
- With swivel joint at the coupling connector for flexible use
- Cold insulated
- Includes 1/4" coupling connector
- Robust aluminium housing



Technical data:

Rivet sizes:	2.4 - 3.2 - 4.0 - 4.8 mm
Stroke length:	14 mm
Driving power:	8677.5 N
Vibration:	< 2.5 ms ²
Noise performance level:	98.6 dbA
Noise pressure level:	85 dbA
Air consumption:	1 l/Hub
Operating pressure:	max. 6.3 bar (90 psi)
Min. tube diameter:	3/8" - 10 mm
Connection thread:	1/4"PT

	B mm	L mm	
515.3102	195.0	290.0	1.50

Pneumatic riveting tool pistol

- Air exhaust through the handle rear end
- For one handed operation with ergonomic design
- For professional riveting, continuous operation
- For steel, aluminium, stainless steel or copper riveting up to 6,4 mm
- With 6 mouth pieces, 4,8 mm is pre assembled
- Especially low noise level
- Swivel joint at the connection thread for flexible use
- Cold insulated
- Includes 1/4" coupling connector
- Robust aluminium housing



Technical data:

Rivet sizes:	3,2 - 4,0 - 4,8 - 6,4 mm
Stroke length:	19 mm
Driving power:	13839,5 N
Vibration:	< 2,5 ms ²
Noise performance level:	85 dbA
Noise pressure level:	73,3 dbA
Air consumption:	1,8 l/Hub
Operating pressure:	max. 6,3 bar (90 psi)
Min. tube diameter:	3/8" - 10 mm
Connection thread:	1/4"PT

	Ø mm	L mm	Icon
515.3101	210.0	340.0	2.00

Cordless riveting tool pistol

- Handy and ergonomic dual component housing
- Universal use for aluminium and steel rivets Ø 2,4/3,2/4,0/4,8 mm
- Approx. 220 rivets per battery
- With practical clockwise and anticlockwise reversing function
- Very short setup time
- Fast change of rivets
- Short processing time
- Stepless controllable motor speed through electronic switch
- 40% extended lifespan due to changeable special carbon brush conductors
- With lithium-ion high performance rechargeable battery
- Includes automatic turn off charging station
- Fast charging function (1 hour)
- Blow mould plastic housing
- In durable plastic storage case



Technical data:

Rivet sizes:	2,4 / 3,2 / 4,0 / 4,8 mm
Stroke length:	15 mm
Vibration:	3,2 ms ²
Noise performance level:	86,9 dbA
Noise pressure level:	75,9 dbA
Driving power:	4.900
Capacity:	10,8 V
Rechargeable battery:	10,8 V - 1,5 Ah

	L mm	B mm	H mm	Spine carbon brushes set	Battery pack	Number of Charge Stations	Icon	
515.4104	235.0	55.0	200.0	515.3595	515.3592	0	0	1.15
515.4105	235.0	55.0	200.0	515.3595	515.3592	1	1	2.69
515.4106	235.0	55.0	200.0	515.3595	515.3592	2	1	3.07

Blind rivets assortment

- Breakable pin made from steel
- In plastic storage case



	Icon
970.0150	400 pcs Blind rivets assortment 250
100 x	2,4 mm
100 x	3,2 mm
100 x	4,0 mm
100 x	4,8 mm

Threaded rivets assortment, aluminium

- Aluminium threaded rivets
- In durable plastic storage case



	Icon
970.0620	150 pcs Threaded rivets assortment, aluminium 220
25 x	M3 x 9 mm
25 x	M4 x 11 mm
25 x	M5 x 13 mm
25 x	M6 x 15 mm
25 x	M8 x 18 mm
25 x	M10 x 21 mm



Threaded rivets assortment, steel

- Steel threaded rivets
- In durable plastic storage case



	Icon
970.0610	150 pcs Threaded rivets assortment, steel 460
25 x	M3 x 9 mm
25 x	M4 x 11 mm
25 x	M5 x 13 mm
25 x	M6 x 15 mm
25 x	M8 x 18 mm
25 x	M10 x 21 mm

Threaded rivets assortment, steel + aluminium

- Steel/aluminium threaded rivets
- In durable plastic storage case



	Icon
970.0630	300 pcs Threaded rivets assortment, steel + aluminium 0.96
25 x	M3 x 9 mm
25 x	M4 x 11 mm
25 x	M5 x 13 mm
25 x	M6 x 15 mm
25 x	M8 x 18 mm
25 x	M10 x 21 mm
25 x	M3 x 9 mm
25 x	M4 x 11 mm
25 x	M5 x 13 mm
25 x	M6 x 15 mm
25 x	M8 x 18 mm
25 x	M10 x 21 mm

WELDING

Electronic surge protection

- Constantly suppresses emerging voltage peaks to safe levels and therefore protects the vehicle power supply against overvoltages
- Prevents damage to the on-board electronics when charging the built-in battery or even during welding work
- Maximum load 200 A (8/20 µs)
- With fuse protection
- Visibility and tone signal in the event of voltages peaks
- With reverse polarity protection
- The connection to the battery takes place via two plastic-coated crocodile pole clamps
- Sturdy workshop design



		Cable length mm	
150.3080	12 V	195	480
150.3045	12/24V	195	480

Welders protective helmet

- Turns fully automatically from bright after dark as soon as the light arch is ignited
- Due to high quality solar cells battery replacement is no longer require
- Equipped with a sensitivity and delaying switch for switching between dark and light to prevent welders blindness when welding at high amp capacity
- Quick switching is possible when changing from seam to spot welding
- Selection switch for reaction time
- Robust multi positional head band
- Complete neck protection
- Face protection to EN 175 / eye protection to EN379 1/2/1



Technical data:

- Switching timed: 1/25.000 s
0.5 s delay
- Window: 98 x 40 mm (3.7/8" x 1.5/8")
- Cassette size: 110 x 90 x 9 mm (4.3/8" x 3.1/2" x 0.35")
- Power requirement: lithium battery + solar cells
- UV / IR protection: according to EN169 / to DIN 16
- Colour selection: variable adjustment from DIN 9-13 standard light adjustment DIN 3 (4)
- Working temperature: -5° to +55°C
- Storage temperature: -20° up to +70°C

	L mm	B mm	H mm	
310.0180	330.0	200.0	200.0	830

Welding apron

- Made from leather
- Adjustable in length
- Size of the waist adjustable
- Breast pocket



		L mm	
985.7019	L	910.0	775
985.7020	XL	1080.0	775

Leather sleeves

- Dark brown
- Made from leather
- Ends with elastic band



	L mm	Count	
985.7021	400.0	2	320

Leather sleeves

- Light brown
- Made from leather
- Ends with elastic band



	L mm	Count	
985.7022	400.0	2	335

Welding coat

- Double leather closure, front
- With hook and loop fastener
- Adjustable cuffs
- Lined collar and with hook and loop fastener for additional protection
- Inner pocket



985.7000	L	1.80
985.7001	XL	1.80
985.7002	XXL	1.82
985.7003	XXXL	1.82

Welding leather gloves

- Made from leather
- Good, comfortable wear
- Can be used for applications with heat
- With open sleeves



	Size mm	
985.7034	M	365
985.7035	L	365
985.7036	XL	365
985.7037	XXL	365

Welding leather gloves, long

- Made from leather
- Extra long
- Good, comfortable wear
- Can be used for applications with heat
- With open sleeves



	Size mm	
985.7038	M	495
985.7039	L	495
985.7040	XL	495
985.7041	XXL	495

Frame for welding protection screen

- Very stable frame made from steel tubing
- With direct rolls
- With 360° swivel joint

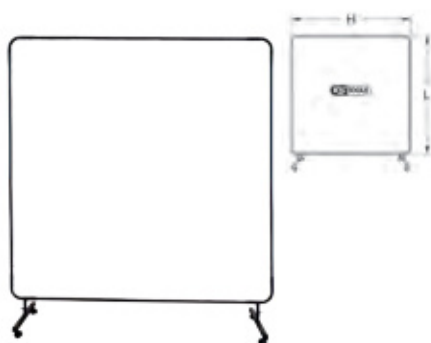

	L mm	H mm	KG
985.7026	1780.0	1780.0	4.50

Welding protection awning

- Resistant against UV rays, flames and wear
- Edges with eyelets at 30cm intervals
- Without frame

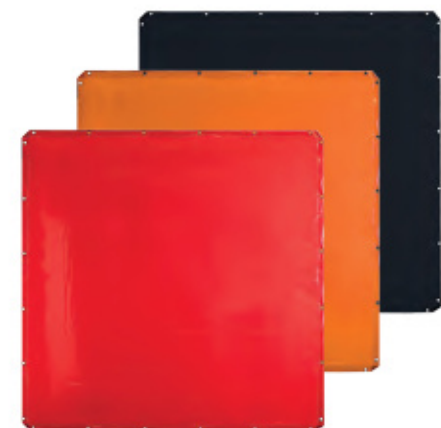

Color code	L mm	H mm	KG
985.7027	1740.0	1740.0	1.72
985.7028	1740.0	1740.0	1.72
985.7029	1740.0	1740.0	1.72

Flame proof mats

- Asbestos free
- Reduced fire risk
- Very flexible
- Good formability

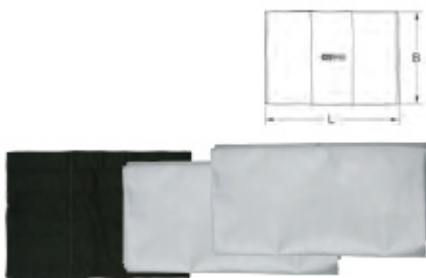

	B mm	L mm	max. T°	KG
610.3350	330.0	500.0	700	330
610.3351	460.0	800.0	700	650
610.3399	1500.0	2000.0	600	2110

Super spotter - Welding gun 220V - 50/60 Hz

- Handy workshop tool
- For the repair of bodywork damage
- For hammering out body panels
- Plastic housing

Technical data:
Attention idle cut-out: 200 Ampere
Attention light cut-out: 200 Ampere



	Length mm	KG
500.8551	285.0	5.46

Slide hammer puller 1.5 kg

- For problem free hammering out of car bodywork panels
- With 1.5 kg slide weight
- Usable in connection with the super spotter
- Special steel



	Length mm	Height mm	Replacement spring-head	KG
500.8559	475.0	80.0	500.8561	2.08

Super spotter - Welding gun set

- Handy workshop tool
- For the repair of bodywork damage
- For hammering out body panels
- By means of special electrodes nails or washers are welded on the sheet metal so the dents can be removed with an impact hammer using accurate blows
- With a heat electrode placed hot points can be set on the sheet metal
- Also contains an electrode for welding copper-plated dome head screws for the reinforcement of housings, parts, etc. directly on the bodywork
- In durable plastic storage case

Technical data:
Attention idle cut-out: 200 Ampere
Attention light cut-out: 200 Ampere



	KG
500.8550	10.39

consists of:

		KG
500.8551	Welding gun 220V, 50/60 Hz	5460
500.8554	Electrode for welding nails, Copper	10
500.8556	Electrode for rivets, magnetic, Copper	10
500.8557	Electrode for washers, Brass	10
500.8558	Heating electrode for hot spots, Brass	10
500.8559	Slide hammer puller 1.5 kg	2080
500.8560	Electrode extension, brass	10
500.8571	Spotter-consumables, welding nails copper coated, 2.0 x 50 mm, pcs 500	660
500.8572	Spotter-consumables, copper plated, welding nails, 2.5 x 50 mm, pcs 100	210
500.8574	Spotter-consumables, 3 x 3.2 mm, pcs 100	30
500.8579	Spotter-consumables, screws copper coated, M 4 x 16 mm, pcs 100	140
500.8592	Washers 8.0 x 16.0 mm copper coated pcs 100	160

Super spotter additional kit

- For removing of car body damage
- Includes the adaptor for the slide hammer puller
- The flexible and strong steel wire profile is used so the processing of securing car body panels
- The movable pull hooks situated can be pulled by the claw fastener straightening the car body and/or the bump on
- It can be hooked on 1-9 pull hooks, at what point exact or extensive enabling the removal of dents



		KG
500.8530	15 pcs Super spotter additional kit	1.04

consists of:

		KG
500.8531	Welding-Electrode for corrugated wire for Spotter 500.8550	23
500.8532	Corrugated wire Ø 2 mm x L=310 mm 10 pcs.	122
500.8533	Corrugated wire positioner magnetic	34
500.8534	Multi hook head with 6 claw connection IG M14x 1.5	315
500.8536	System adaptor for slide hammer puller IG M14x1.5, for use with 500.8559	86
500.8572	Spotter consumables, copper plated, welding nails, 2.5 x 50 mm, pcs 100	210

Super spotter electrodes

- Usable in connection with the super spotter
- Copper and/or brass



		KG
500.8554	Electrode for welding nails, Copper	10
500.8556	Electrode for rivets, magnetic, Copper	10
500.8562	Electrode for screws, Copper	20
500.8557	Electrode for washers, Brass	10
500.8558	Heating electrode for hot spots, Brass	10
500.8560	Electrode extension, brass	10

Super spotter consumables

- Usable in connection with the super spotter
- For the reinforcement of the car body
- Copper coated



500.8570	Welding nail, 100pcs, 2x50mm	140
500.8571	Welding nail, 500pcs, 2x50mm	660
500.8572	Welding nail, 100pcs, 2.5x50mm	210
500.8573	Welding nail, 500pcs, 2.5x50mm	1150
500.8592	Washer, 100pcs, 8x16mm	160
500.8595	Triangular-washer 2.5 x 50.0 mm copper coated 100pcs	500
500.8574	Rivet, 100pcs, 3x3.2mm	30
500.8575	Rivet, 100pcs, 3x4.5mm	40
500.8576	Rivet, 100pcs, 5x8.2mm	40
500.8579	Screw, 100pcs, M4x16mm	140

SURFACE TREATMENT

Magnet protector set

- Suitable for protecting door edges and trims
- Ideal for polishing, painting and grinding
- Flexible use thanks to flexible magnetic fill
- Surface made from rugged special plastic
- Easy to use

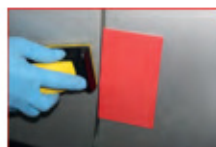

903.1040	2 pcs Magnet protector set	131

consists of:

903.1041	Magnet protector, small, 120 mm	51
903.1042	Magnet protector, large, 150 mm	80

Pneumatic sand blaster

- Ideal for specific working
- With integrated storage tank 600 cm³
- Suitable for blasting material grain size 46-100
- Suitable for quartz sand, glass beads, plastic granulate, aluminium oxide, standard corundum and glass granulate
- Supply for blasting material can be switched off and therefore also be used as normal pneumatic guns
- ABS tank
- Robust steel handle
- Steel nozzle, maintenance-free

Application range: Paint stripping, paint removal, rust removal, cleaning, surface cleaning



Technical data:
 Operating pressure: max. 6.3 bar (90 psi)
 Air consumption: 200 l/min
 Min. tube diameter: 3/8" - 10 mm
 Connection thread: 1/4"NPT

	Length mm	Height mm	Ø mm	
515.1909	260.0	280.0	5,0	1.30

Pneumatic pencil grinder, 70.000 rpm

- Straight design
- Air exhaust through the used air tube
- Ideal for carbide, corundum and tungsten carbide burrs
- For working in hard to access areas
- Very handy and compact construction
- Suitable for different repair works
- With stepless speed regulation
- Vibration dampened
- Cold insulated handle
- Includes 1/4" coupling connector and chuck wrench
- Aluminium housing



Technical data:
 Tube length: 1 m
 Tube diameter: 5 mm
 Chuck capacity: 3 mm
 Capacity: 150 KW
 No load current: 70000 r.p.m.
 Vibration: < 2.5 ms²
 Noise performance level: 86 dbA
 Noise pressure level: 74 dbA
 Air consumption: 140 l/min
 Operating pressure: max. 6.3 bar (90 psi)
 Min. tube diameter: 1/4" - 6,35 mm
 Connection thread: 1/4"PT

	D mm	L mm	
515.3198	16.0	132.0	330

SlimPOWER mini-pneumatic die grinder, straight

- Straight design
- Air exhaust through the handle rear end
- For one handed operation with ergonomic design
- For HM mills, mini cutting discs and grinding heads with a 6 mm shaft
- Ideal for grinding, polishing and engraving work
- For working in hard to access areas
- Very handy and compact construction
- Secure operation lever with locking device
- With stepless speed regulation
- Vibration dampened
- Very compact construction
- Includes 1/4" coupling connector
- Robust housing



Technical data:
 Chuck: 6 mm
 Capacity: 230 Watt
 No load current: 25000 r.p.m.
 Vibration: < 1.5 ms²
 Noise performance level: 95 dbA
 Noise pressure level: 81 dbA
 Air consumption: 319.93 l/min
 Min. tube diameter: 1/4" - 6,4 mm
 Operating pressure: max. 5.5 bar (80 psi)
 Connection thread: 1/4"PT

	B mm	L mm	
515.5030	35.0	123.0	300

Mini pneumatic die grinder, straight

- Straight design
- Air exhaust through the handle rear end
- For one handed operation with ergonomic design
- For HM mills, mini cutting discs and grinding heads with a 6 mm shaft
- Ideal for grinding, polishing and engraving work
- For working in hard to access areas
- Very handy and compact construction
- Secure operation lever with locking device
- With stepless speed regulation
- Number of revolutions adjustable through regulating screw
- Vibration dampened
- Cold insulated handle
- Includes 1/4" coupling connector
- Ultra light robust housing from special plastic



Technical data:
 Chuck: 6 mm
 Capacity: 250 Watt
 No load current: 25000 r.p.m.
 Vibration: < 0,1 ms²
 Noise performance level: 95 dbA
 Noise pressure level: 82 dbA
 Air consumption: 85 l/min
 Operating pressure: max. 6.3 bar (90 psi)
 Min. tube diameter: 3/8" - 10 mm
 Connection thread: 1/4"PT

	B mm	L mm	
515.3005	365.0	155.0	920

Pneumatic die grinder

- Straight design
- Air exhaust through the handle rear end
- For one handed operation with ergonomic design
- For HM mills, mini cutting discs and grinding heads with a 6 mm shaft
- Ideal for grinding, polishing and engraving work
- For working in hard to access areas
- Very handy and compact construction
- Secure operation lever with locking device
- Number of revolutions adjustable through regulating screw
- Vibration dampened
- Cold insulated handle
- Includes 1/4" coupling connector
- Ultra light robust housing special plastic



Technical data:

Chuck:	6 mm
Capacity:	330 Watt
No load current:	21000 r.p.m.
Vibration:	< 0,1 ms ²
Noise performance level:	95 dbA
Noise pressure level:	82 dbA
Air consumption:	85 l/min
Operating pressure:	6,3 bar (90 psi)
Min. tube diameter:	3/8" - 10 mm
Connection thread:	1/4"PT

	B mm	L mm	W
515.3010	44.0	175.0	920

Long shaft die grinder

- Straight design
- Air exhaust through the handle rear end
- For one handed operation with ergonomic design
- For HM mills, mini cutting discs and grinding heads with a 6 mm shaft
- Ideal for grinding, polishing and engraving work
- For working in deep lying areas
- Secure operation lever with locking device
- With stepless speed regulation
- Number of revolutions adjustable through regulating screw
- Vibration dampened
- Cold insulated handle
- Includes 1/4" coupling connector
- Ultra light robust housing special plastic

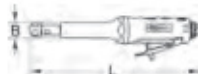

Technical data:

Chuck:	6 mm
Capacity:	330 Watt
No load current:	22000 r.p.m.
Vibration:	< 0,1 ms ²
Noise performance level:	95 dbA
Noise pressure level:	82 dbA
Air consumption:	85 l/min
Operating pressure:	max. 6,3 bar (90 psi)
Min. tube diameter:	3/8" - 10 mm
Connection thread:	1/4"PT

	B mm	L mm	W
515.3015	26.5	280.0	1.08

Long shaft die grinder set

- With 25 mini grinding wheels and mounting mandrel
- Straight design
- Air exhaust through the handle rear end
- For one handed operation with ergonomic design
- For HM mills, mini cutting discs and grindstone with 6 mm shaft
- Ideal for grinding, polishing and engraving work
- For working in deep lying areas
- Secure operation lever with locking device
- With stepless speed regulation
- Number of revolutions adjustable through regulating screw
- Vibration dampened
- Cold insulated handle
- Includes 1/4" coupling connector
- Ultra light robust housing from special plastic

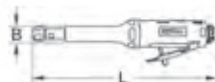

Technical data:

Chuck:	6 mm
Capacity:	330 Watt
No load current:	22000 r.p.m.
Vibration:	< 0,1 ms ²
Noise performance level:	95 dbA
Noise pressure level:	82 dbA
Air consumption:	85 l/min
Operating pressure:	max. 6,3 bar (90 psi)
Min. tube diameter:	3/8" - 10 mm
Connection thread:	1/4"PT

	B mm	L mm	W
515.3016	26.5	280.0	1.25

consists of:

		W
515.3015	Long shaft die grinder, 22000 r.p.m.	1.08
337.2005	High performances thin disk, 1mm, pack of 25	0.10
515.3017	Clamping mandrel M6 L, thin cutting disk	0.07



SlimPOWER mini-pneumatic angled die grinder

- Straight design
- Air exhaust through the handle rear end
- For one handed operation with ergonomic design
- For HM mills, mini cutting discs and grinding heads with a 6 mm shaft
- Ideal for grinding, polishing and engraving work
- For working in hard to access areas
- Secure operation lever with locking device
- With stepless speed regulation
- Vibration dampened
- Very compact construction
- Includes 1/4" coupling connector
- Robust housing



Technical data:

Chuck:	6 mm
Capacity:	190 Watt
No load current:	19000 r.p.m.
Vibration:	< 1,5 ms ²
Noise performance level:	95 dbA
Noise pressure level:	82 dbA
Air consumption:	240.66 l/min
Min. tube diameter:	1/4" - 4,8 mm
Operating pressure:	max. 5,5 bar (80 psi)
Connection thread:	1/4"

	B mm	L mm	W
515.5035	75.0	123.0	300

SlimPOWER mini-pneumatic angled die grinder

- Straight design
- Air exhaust through the handle rear end
- For one handed operation with ergonomic design
- For HM mills, mini cutting discs and grinding heads with a 6 mm shaft
- Ideal for grinding, polishing and engraving work
- For working in hard to access areas
- Secure operation lever with locking device
- With stepless speed regulation
- Vibration dampened
- Includes 1/4" coupling connector
- Robust housing



Technical data:

Chuck:	6 mm
Capacity:	230 Watt
No load current:	20000 r.p.m.
Vibration:	< 1,5 ms ²
Noise performance level:	95 dbA
Noise pressure level:	83 dbA
Air consumption:	319.93 l/min
Min. tube diameter:	1/4" - 6,4 mm
Operating pressure:	max. 6,3 bar (90 psi)
Connection thread:	1/4"

	B mm	L mm	W
515.5040	70.0	270.0	700

Pneumatic angled die grinder

- 90° offset execution
- Air exhaust through the handle rear end
- For one handed operation with ergonomic design
- For HM mills, mini cutting discs and grinding heads with a 6 mm shaft
- Ideal for grinding, polishing and engraving work
- For working in hard to access areas
- Secure operation lever with locking device
- With stepless speed regulation
- Number of revolutions adjustable through regulating screw
- Vibration dampened
- Cold insulated handle
- Includes 1/4" coupling connector
- Ultra light robust housing from special plastic
- Grease nipple for maintenance on striking mechanism ensures long life (KS grease gun 980.1070)



Technical data:

Angle size:	80 mm
Chuck:	6 mm
Capacity:	330 Watt
No load current:	18000 r.p.m.
Vibration:	< 0,1 ms ²
Noise performance level:	95 dbA
Noise pressure level:	82 dbA
Air consumption:	85 l/min
Operating pressure:	max. 6,3 bar (90 psi)
Min. tube diameter:	3/8" - 10 mm
Connection thread:	1/4"PT

	B mm	L mm	kg
515.3020	80,0	180,0	920

Our wide range of tube/sheet drills and taper/deburring countersinkers can be found on pages 509 to 523 of our Hand Tools catalogue.

SlimPOWER mini-pneumatic burnisher

- 90° offset execution
- Air exhaust through the handle rear end
- For one hand operation
- Ideal for curved cutting
- For working in hard to access areas
- Secure operation lever with locking device
- With stepless speed regulation
- Vibration dampened
- Very compact construction
- Receiver: External thread
- Includes 3 Velcro receivers
- Includes 1/4" coupling connector
- Robust housing



Technical data:

Capacity:	190 Watt
No load current:	4000 r.p.m.
Sponge diameter:	50 + 75 mm
Polishing sponge diameter:	46 mm
Vibration:	1,5 ms ²
Noise performance level:	95 dbA
Noise pressure level:	81 dbA
Air consumption:	240.66 l/min
Min. tube diameter:	1/4" - 4,8 mm
Operating pressure:	max. 5,5 bar (80 psi)
Connection thread:	1/4"

	B mm	L mm	kg
515.5125	55,0	140,0	600

Grinding disc

- With Velcro receiver
- With internal thread receiver



	Ø mm	Material	Content	kg
515.5101	46,0	flexible	5	275
515.5102	75,0	flexible	5	125
515.5103	46,0	rigid	5	55

Burnishing pads

- For burnishing of smooth surfaces



	Ø mm	Material	Colour code	Content	kg
515.5126	50,0	plastic	yellow	5	10
515.5122	85,0	plastic	yellow	5	55
515.5127	50,0	plastic	white	5	10
515.5123	85,0	plastic	white	5	55
515.5128	50,0	plastic	black	5	10
515.5129	50,0	leather		5	48
515.5124	80,0	leather		5	80

Mini pneumatic burnisher set

- For hard to reach places and improvement work
- With non-slip soft-grip-handle
- 90° offset execution
- Air exhaust through the handle rear end
- For one hand operation
- Ideal for curved cutting
- For working in hard to access areas
- Vibration dampened
- Very compact construction
- Grinding disc with Velcro
- Includes 1/4" coupling connector
- Receiver: Internal thread
- Robust housing
- In durable plastic storage case

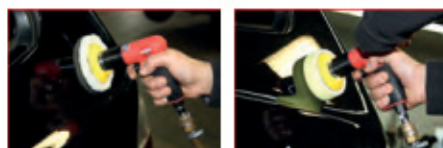

Technical data:

No load current:	2500 r.p.m.
Vibration:	1,5 ms ²
Noise performance level:	92 dbA
Noise pressure level:	81 dbA
Air consumption:	113 l/min
Operating pressure:	max. 5,2
Min. tube diameter:	10 mm
Connection thread:	1/4"

	kg
515.5120 5 pcs Mini pneumatic burnisher set	1,96

consists of:

		kg
515.5121	1/4" mini burnishing machine	1000
515.5122	Burnishing pads yellow, Ø 85,0mm	55
515.5123	Burnishing pads white, Ø 85,0mm	55
515.5124	Burnishing pads, Ø 80,0mm	80
515.5112	Grinding disc Ø76,5 mm	20

Grinding disc

- With Velcro receiver
- With external thread receiver



	Ø mm	Material	Content	kg
515.5113	46,0	flexible	5	13
515.5112	76,5	flexible	5	20

Burnishing pads

- For burnishing of smooth surfaces



	Ø mm	Material	Colour code	Content	kg
515.5126	50,0	plastic	yellow	5	10
515.5122	85,0	plastic	yellow	5	55
515.5127	50,0	plastic	white	5	10
515.5123	85,0	plastic	white	5	55
515.5128	50,0	plastic	black	5	10
515.5129	50,0	leather		5	48
515.5124	80,0	leather		5	80

SlimPOWER mini-pneumatic grinding machine

- 90° offset execution
- Air exhaust through the handle rear end
- For one hand operation
- Ideal for curved cutting
- For working in hard to access areas
- Secure operation lever with locking device
- With stepless speed regulation
- Vibration dampened
- Very compact construction
- Includes 1/4" coupling connector
- Receiver: External thread
- Robust housing
- Incl. three grinding discs

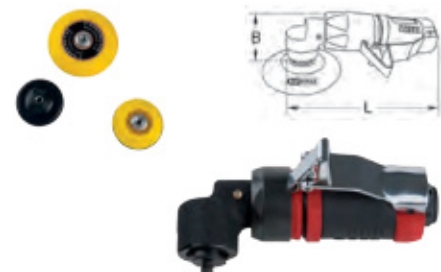

Technical data:

Capacity:	190 Watt
No load current:	16500 r.p.m.
Sponge diameter:	50 + 75 mm
Polishing sponge diameter:	46 mm
Vibration:	< 1,5 ms ²
Noise performance level:	95 dbA
Noise pressure level:	81 dbA
Air consumption:	240.66 l/min
Min. tube diameter:	1/4" - 4,8 mm
Operating pressure:	max. 5,5 bar (80 psi)
Connection thread:	1/4"

	B mm	L mm	kg
515.5100	40,0	120,0	300

Grinding disc

- With Velcro receiver
- With internal thread receiver



	Ø mm	Material	Content	Weight
515.5101	46,0	flexible	5	275
515.5102	75,0	flexible	5	125
515.5103	46,0	rigid	5	55

Grinding pads

- For polishing rough surfaces made from wood, metal, varnish and natural stone
- For breaking edges



	Ø mm	Grain	Content	Weight
515.5119	50,0	320	10	16
515.5116	75,0	320	10	19
515.5118	50,0	400	10	16
515.5115	75,0	400	10	19
515.5117	50,0	600	10	16
515.5114	75,0	600	10	19

SlimPOWER mini-pneumatic grinding machine for small pads

- 90° offset execution
- Air exhaust through the handle rear end
- For one hand operation
- Ideal for curved cutting
- For working in hard to access areas
- Secure operation lever with locking device
- With stepless speed regulation
- Vibration dampened
- Very compact construction
- For screw in pads with 26.7 mm diameter
- Includes 1/4" coupling connector
- Receiver: Internal thread
- Robust housing

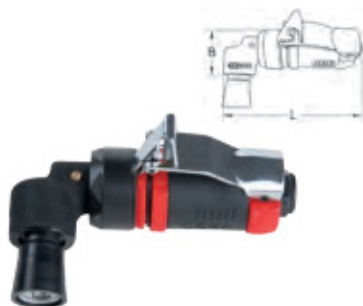

Technical data:
 No load current: 16500 r.p.m.
 Vibration: < 1,5 ms²
 Noise performance level: 92 dbA
 Noise pressure level: 81 dbA
 Air consumption: 240.66 l/min
 Min. tube diameter: 1/4" - 4,8 mm
 Operating pressure: max. 5,5 bar (80 psi)
 Connection thread: 1/4"

	B mm	L mm	Weight
515.5070	65,0	120,0	300

Grinding pads 26.7 mm

- For polishing rough surfaces made from wood, metal, varnish and natural stone
- For breaking edges
- With external thread receiver



	Material	Ø mm	Grain	Color code	Content	Weight
515.5071		26,7	60	brown	10	10
515.5072		26,7	80	brown	10	20
515.5073		26,7	150	purple	10	20
515.5074		26,7	300	blue	10	20
515.5075	Strip Rad	26,7		black	10	25

SlimPOWER mini-pneumatic grinding machine for large pads

- 90° offset execution
- Air exhaust through the handle rear end
- For one hand operation
- Ideal for curved cutting
- For working in hard to access areas
- Secure operation lever with locking device
- With stepless speed regulation
- Vibration dampened
- Very compact construction
- For screw in pads with 50.0 mm diameter
- Includes 1/4" coupling connector
- Receiver: Internal thread
- Robust housing



Technical data:
 No load current: 16500 r.p.m.
 Vibration: < 1,5 ms²
 Noise performance level: 92 dbA
 Noise pressure level: 81 dbA
 Air consumption: 240.66 l/min
 Min. tube diameter: 1/4" - 4,8 mm
 Operating pressure: max. 5,5 bar (80 psi)
 Connection thread: 1/4"

	B mm	L mm	Weight
515.5080	70,0	120,0	300

Grinding pads 50.0 mm

- For polishing rough surfaces made from wood, metal, varnish and natural stone
- For breaking edges
- With external thread receiver



	Material	Ø mm	Grain	Color code	Content	Weight
515.5081	Scouring wool	50,0		white	10	60
515.5083	Sand paper	50,0	80	brown	10	60
515.5084	Sand paper	50,0	150	purple	10	60
515.5082	Sand paper	50,0	240	brown	10	30
515.5085	Sand paper	50,0	300	blue	10	60
515.5086	Strip Rad	50,0		purple	10	100
515.5087	Strip Rad	50,0		black	10	100

Belt sander

- With non slip soft grip handle
- Air exhaust through the handle rear end
- Working head is 360° adjustable
- Adjustable for quick sanding belt change
- Ideal for narrow areas (10 mm belt width)
- Secure operation lever with locking device
- With stepless speed regulation
- Number of revolutions adjustable through regulating screw
- Vibration dampened
- Cold insulated handle
- Includes 1/4" coupling connector
- Light aluminium housing



Technical data:
 Belt speed: 1188 m/min
 No load current: 18000 r.p.m.
 Vibration: < 2,0 ms²
 Noise performance level: 81 dbA
 Noise pressure level: 73 dbA
 Air consumption: 142 l/min
 Operating pressure: max. 6,3 bar (90 psi)
 Min. tube diameter: 3/8" - 10 mm
 Connection thread: 1/4"PT

	L1 mm	L2 mm	Weight
515.3549	150,0	170,0	800

Sanding belt for belt sander

- Sanding belt for belt sander 515.3549



	Grain	Content	Weight
515.3551	80	10	60
515.3552	100	10	80
515.3553	120	10	100

Pneumatic disc cutter

- Air exhaust through the handle rear end
- For grinding wheels up to Ø 125 mm x 22 mm
- With safety cover
- For grinding metal sheet and steel
- Secure operation lever with locking device
- With detachable second handle
- With stepless speed regulation
- Vibration dampened
- Cold insulated handle
- Includes 1/4" coupling connector
- Ultra light robust housing from special plastic



Technical data:
 Tool holder: 5/8" - 11 Gang
 No load current: 10000 r.p.m.
 Capacity: 700 Watt
 Vibration: < 0,2 ms²
 Noise performance level: 103 dbA
 Noise pressure level: 90 dbA
 Air consumption: 142 l/min
 Operating pressure: max. 6,3 bar (90 psi)
 Min. tube diameter: 3/8" - 10 mm
 Connection thread: 1/4"PT

	B mm	L mm	Weight
515.3045	95,0	210,0	1,75

Pneumatic disc cutter

- Air exhaust through the handle rear end
- For one handed operation with ergonomic design
- For cutting wheels up to \varnothing 75 mm x 10 mm
- With safety cover
- For cutting metal sheet and steel
- Secure operation lever with locking device
- For working in inaccessible places
- With stepless speed regulation
- Number of revolutions adjustable through regulating screw
- Vibration dampened
- Cold insulated handle
- Includes 1/4" coupling connector
- Ultra light robust housing special plastic



Technical data:	
Tool holder:	5/16" - 24 mm
No load current:	21000 r.p.m.
Capacity:	330 Watt
Vibration:	< 0,2 ms ²
Noise performance level:	95 dbA
Noise pressure level:	82 dbA
Air consumption:	85 l/min
Operating pressure:	max. 6,3 bar (90 psi)
Min. tube diameter:	3/8" - 10 mm
Connection thread:	1/4"PT

	B mm	L mm	
515.3040	80.0	195.0	1.00

Mini pneumatic random orbital sander

- For hard to reach places and improvement work
- With non-slip soft-grip-handle
- 90° offset execution
- Air exhaust through the handle rear end
- For one hand operation
- Ideal for curved cutting
- For working in hard to access areas
- Vibration dampened
- Very compact construction
- Includes 1/4" coupling connector
- Receiver: Internal thread
- Robust housing
- Grinding disc with Velcro
- In durable plastic storage case



Technical data:	
No load current:	15000 r.p.m.
Vibration:	< 1,5 ms ²
Noise performance level:	92 dbA
Noise pressure level:	81 dbA
Air consumption:	113 l/min
Operating pressure:	max. 5,2
Min. tube diameter:	10 mm
Connection thread:	1/4"

515.5110 63 pcs Mini pneumatic random orbital sander set	1.45

consists of:

515.5111	Mini random orbital sander	700
515.5119	Grinding pads, grit 320 \varnothing 50mm, 10 pcs	16
515.5118	Grinding pads, grit 400 \varnothing 50mm, 10 pcs	16
515.5117	Grinding pads, grit 600 \varnothing 50mm, 10 pcs	16
515.5116	Grinding pads, grit 320 \varnothing 75mm, 10 pcs	19
515.5115	Grinding pads, grit 400 \varnothing 75mm, 10 pcs	19
515.5114	Grinding pads, grit 600 \varnothing 75mm, 10 pcs	19
515.5113	Grinding disc \varnothing 46.0 mm	13
515.5112	Grinding disc \varnothing 76.5 mm	20

Grinding disc

- With Velcro receiver
- With external thread receiver



	\varnothing mm	Material	Count	
515.5113	46,0	flexible	5	13
515.5112	76,5	flexible	5	20

Grinding pads

- For polishing rough surfaces made from wood, metal, varnish and natural stone
- For breaking edges



	\varnothing mm	Grit	Count	
515.5119	50,0	320	10	16
515.5116	75,0	320	10	19
515.5118	50,0	400	10	16
515.5115	75,0	400	10	19
515.5117	50,0	600	10	16
515.5114	75,0	600	10	19

Fine finish e centric sander with dust extraction

- Air exhaust through the used air tube
- With ergonomic design for fatigue free working
- Compact construction height and light composite housing for controlled working
- For sanding or polishing
- Alternatively can be used with dust bag or industrial vacuum cleaner
- Includes fabric dust collection bag
- With 6 punched hole in pitch circle: 80 mm / \varnothing 11 mm
- With stepless speed regulation
- Low vibration
- Cold insulated handle
- Includes 1/4" coupling connector
- Ultra light robust housing special plastic



Technical data:	
Sanding radius:	2,5 mm
Velcro disc receiver:	\varnothing 152,4 mm = 6"
Tube length:	2 m
Capacity:	240 Watt
No load current:	10000 r.p.m.
Vibration:	3,5 ms ²
Noise performance level:	71 dbA
Noise pressure level:	60 dbA
Air consumption:	255 l/min
Operating pressure:	max. 6,3 bar (90 psi)
Min. tube diameter:	3/8" - 10 mm
Connection thread:	1/4"PT

	D mm	L mm	
515.3061	150.0	196.0	1.50

Rapid removal eccentric sander with dust extraction

- Air exhaust through the used air tube
- With ergonomic design for fatigue free working
- Compact construction height and light composite housing for controlled working
- For sanding or polishing
- Alternatively can be used with dust bag or industrial vacuum cleaner
- Includes fabric dust collection bag
- With 6 punched hole in pitch circle: 80 mm / \varnothing 11 mm
- With stepless speed regulation
- Low vibration
- Cold insulated handle
- Includes 1/4" coupling connector
- Ultra light robust housing special plastic



Technical data:	
Sanding radius:	5 mm
Velcro disc receiver:	\varnothing 152,4 mm = 6"
Tube length:	2 m
Capacity:	240 Watt
No load current:	10000 r.p.m.
Vibration:	3,5 ms ²
Noise performance level:	71 dbA
Noise pressure level:	60 dbA
Air consumption:	225 l/min
Operating pressure:	max. 6,3 bar (90 psi)
Min. tube diameter:	1/4" - 6,35 mm
Connection thread:	1/4"PT

	D mm	L mm	
515.3066	150.0	100.0	900

Pneumatic multi-grinder set

- For removing underbody coating, sealant, rust, corrosion, clingages, paints, film, text as well as for paint stripping
- With non-slip soft-grip-handle
- For hard to reach places
- Air exhaust through the handle rear end
- Easy operation
- Ideal for grinding and erasing work
- For working in hard to access areas
- Vibration dampened
- Includes 1/4" coupling connector
- Robust housing
- In durable plastic storage case



Technical data:	
No load current:	3500 r.p.m.
Vibration:	< 4,4 ms ²
Noise performance level:	94 dbA
Noise pressure level:	88 dbA
Air consumption:	113 l/min
Operating pressure:	6,2
Min. tube diameter:	1/4" - 6,3 mm
Connection thread:	1/4"

515.5130 17 pcs Pneumatic multi-grinder set	4.67

consists of:

515.5131	Mini multi-grinder with handle, 272 mm	1400	
515.5132	Film eraser, light execution, 105mm, pack of 5	1325	
515.5133	Film eraser, dark execution, 105mm, pack of 5	1400	
515.5134	Adaptor for film eraser, pack of 5	100	
515.5135	Brushing belt, coarse, curved tips, 11 mm, pack of 5	250	
515.5136	Brushing belt, coarse, curved tips, 23 mm, pack of 5	375	
515.5137	Brushing belt, straight tips, 11 mm, pack of 5	325	
515.5138	Brushing belt, straight tips, 23 mm, pack of 5	350	
515.5139	Eliminator disc 15 mm, pack of 5	500	
515.5166	Adaptor for 11 mm Ø brushing belt, pack of 5	80	
515.5167	Adaptor for individual eliminator disc, 19 mm, pack of 5	550	
515.5168	Adaptor for double eliminator disc, 31 mm, pack of 5	650	

Pneumatic erasing machine

- Straight design
- Air exhaust through the handle rear end
- For one handed operation with ergonomic design
- Ideal for removing of stickers glue and color remainders
- Includes neutral colored rubber eraser disc
- Stepless speed regulation
- Number of revolutions adjustable through regulating screw
- Vibration dampened
- Cold insulated handle
- Includes 1/4" coupling connector
- Ultra light robust housing from special plastic

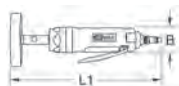

Technical data:

Tool holder:	5/16" - 24
Capacity:	330 Watt
No load current:	2600 r.p.m.
Vibration acceleration:	< 0,70 m/s ²
Noise performance level:	95 dbA
Noise pressure level:	82 dbA
Air consumption:	85 l/min
Operating pressure:	max. 6,3 bar (90 psi)
Min. tube diameter:	3/8" - 10 mm
Connection thread:	1/4"PT

	B mm	L mm	Eraser wheels	
515.1244	40,0	225,0	515.1243	1,08

Rubber eraser disc

- For removing of stickers, glue and color remainders on varnished areas
- Includes neutral colored rubber eraser preventing a smearing on the surface
- Not suitable for pneumatic die grinders



Technical data:

Speed:	4000 rpm
Shaft:	M8

	B mm	D mm	Count	
515.1243	15,0	90,0	1	110
515.1285	15,0	90,0	6	660

Soldering wood set

- Suitable for working hot-tinned surfaces
- Comprehensive set with various soldering woods
- Beech wood



903.1010	5 pcs	Soldering wood set	460

consists of:

903.1011	Soldering wood chock, 180 x 53 x 34 mm	120	
903.1012	Soldering wood chock, 158 x 40 x 50 mm	120	
903.1013	Soldering wood chock, 130 x 41 x 40 mm	80	
903.1016	Soldering wood block, 92 x 30 x 25 mm	40	
903.1017	Soldering wood block, 92 x 47 x 20 mm	60	

Stainless steel spatula with short handle

- With two component handle
- Ground
- Polished
- With suspension hole
- Extremely long service life
- Rust-proof
- Stainless steel



	Length mm	Width mm	
144.0631	50,0	100,0	20
144.0632	75,0	113,0	30
144.0633	100,0	116,0	50
144.0634	150,0	120,0	85

Stainless steel scraper

- With two component handle
- Ground
- Polished
- Stainless steel



	L mm	B mm	
144.0622	225,0	30,0	72
144.0624	225,0	40,0	73
144.0625	225,0	50,0	75
144.0626	225,0	60,0	84
144.0628	225,0	80,0	85

STAINLESS STEEL scraper

- With wooden handle
- Ground
- Polished
- With hanging hole
- Suitable for use at extremely low temperatures
- Extreme resistance to intergranular corrosion and oxidation
- Extremely long service life
- Autoclavable (heating of the tools to over 100°C to kill germs)
- Rust-proof and acid resistant
- Stainless steel



	L mm	B mm	
907.2261	225,0	25,0	70
907.2262	225,0	38,0	70
907.2263	225,0	50,0	70
907.2264	225,0	63,0	70
907.2265	225,0	75,0	80

Sanding block with sponge rubber backing

- Accepts emery and sandpaper etc
- Moulded handle ensures a comfortable grip
- Ideally suited for working on surfaces
- Clamping clips made from stainless steel
- Special plastic



	L mm	B mm	
515.3095	210,0	105,0	330

Grinding hand block set

- Ideal for grinding and polishing
- For affixing sandpaper, etc. by hook and loop fastener
- Ideally suited to working on level surfaces
- With ergonomic design for fatigue-free working
- Low height
- With dust suction in combination with an industrial vacuum cleaner
- With non-slip soft touch handle
- Ultra-light robust housing from special plastic

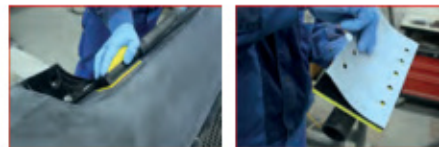

140.3065	3 pcs	Grinding hand block set	690

consists of:

140.3066	Grinding hand block, small, 70 x 125 mm	180	
140.3067	Grinding hand block, medium, 90 x 175 mm	215	
140.3068	Grinding hand block, large, 115 x 225 mm	290	

INTERNAL CLEANING

Plasma air-cleaner with ionisator technology

- Eliminates odours and disinfects the interior of the vehicle
- Compact, lightweight, and high ozone emission
- For use in closed passenger compartments
- In odour elimination mode, it switches off automatically after 60 minutes
- In disinfection mode, it automatically switches off after 30 minutes and immediately switches to odour elimination mode for 30 minutes
- Works without chemical additives, guaranteed to leave no residue
- It leaves no traces, even on sensitive surfaces
- Removes mould, bacteria, fungus and mites
- Includes an active carbon HEPA technology replacement filter
- Simple operation



Technical data:

Dimensions:	173x122x49 mm
Battery type:	Lithium-ion
Rechargeable battery:	850 mAh
Operational voltage:	DC 12-24V / AC 100-240V / 50/60 Hz
Power consumption:	5 W
Ozone transformation:	5 mg/h
Negative ion concentration:	3000 pcs/cm ²
Covering scope:	15m ²

Replacement type	Standard type	Icon	
550.1183	550.1199	550.1189	360

Compressed-air cleaning guns

- Ideal for spraying cleaning fluids or oil
- With integrated storage tank 750 cm³
- Simple handling
- Robust design
- Coated metal

Application range: Waxing, sealing, impregnating, spraying cold cleaners in or on to surfaces, washing agents, antirust agents, spray oils, etc.



Technical data:

Operating pressure:	max. 6,3 bar (90 psi)
Air consumption:	170 l/min
Min. tube diameter:	3/8" - 10 mm
Connection thread:	1/4"

Length inch	Height mm	Ø mm	Icon	
515.1911	310.0	230.0	4.5	500

Pneumatic cleaning gun

- Ideal for professional cleaning of cushions, door pillars, ventilation channels, carpets, foot mats, fabric seats, etc.
- Pneumatic-operated with simple handling
- Unique, cyclonic, ball bearing mounted rotation cleaning technology
- Efficient and energy-saving using targeted air turbulence
- For all possible surfaces, cleaned damp or dry
- Also suitable for hard-to-reach places, e.g. between seats and seams
- Cleaned surfaces also dry extremely quickly thanks for the fine misted cleaning solution
- With pressure regulator
- Includes 360° rotating and 30° angled ball joint and plug nipple



Technical data:

No load current:	8000 r.p.m.
Vibration:	0,64 ms ⁻²
Noise performance level:	110 dbA
Noise pressure level:	90 dbA
Air consumption:	160 l/min
Operating pressure:	max. 6,3 bar (90 psi)
Min. tube diameter:	3/8" - 10,0 mm
Connection thread:	1/4"PT

Icon		
515.1980	1000 ml	755

Cleaning Brush-Adaptor

- Ideal addition for cleaning the interior
- Can be used in conjunction with compressed-air cleaning guns (515.1980)
- With screw connection
- Plastic housing



Icon		
515.1983	Cleaning Brush-Adaptor	27

Cleaning Brush

- Ideal addition for cleaning the interior
- Can be used in conjunction with compressed-air cleaning guns (515.1980)
- With suspension hole
- Plastic housing



Icon		
515.1986	Cleaning Brush	60

WIRE BRUSHES

Steel hand wire brush 3 rowed

- 3 rowed
- Universal use
- Handle made out of wood
- For surface preparation
- With steel bristles

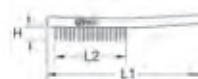

	H mm	L1 mm	L2 mm	Icon
201.2305	32.0	290.0	138.0	120

Steel hand wire brush 4 rowed

- 4 rowed
- Universal use
- Handle made out of wood
- For surface preparation
- With steel bristles

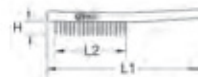

	H mm	L1 mm	L2 mm	Icon
201.2311	32.0	290.0	138.0	120

Stainless steel hand wire hand brush 3 rowed

- 3 rowed
- Universal use
- Handle made out of wood
- For surface preparation
- With stainless steel bristles

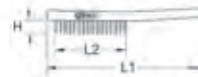

	H mm	L1 mm	L2 mm	Icon
201.2310	32.0	290.0	138.0	120

Stainless steel hand wire hand brush 4 rowed

- 4 rowed
- Universal use
- Handle made out of wood
- For surface preparation
- With stainless steel bristles

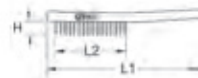

	H mm	L1 mm	L2 mm	Icon
201.2306	32.0	290.0	138.0	100

Brass wire hand brush 3 rowed

- 3 rowed
- Universal usage
- Plastic hand grip casing
- For surface preparation
- Straight brass wire

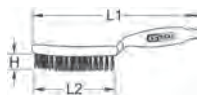

	H mm	L1 mm	L2 mm	
201.2326	25.0	285.0	130.0	105

Steel wire hand brush 4 rowed

- 4 rowed
- Universal usage
- Plastic hand grip casing
- For surface preparation
- Straight steel wire



	H mm	L1 mm	L2 mm	
201.2325	25.0	285.0	130.0	120

Steel wire jar brush 0,3 mm

- With 6 mm mandril
- To enable with high rotary speed
- Long durability through compact border
- For use with drill machine
- For surface preparation
- Crimped steel wire

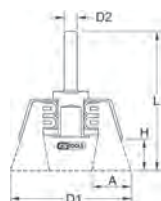

	RPM max	A mm	D1 mm	D2 mm	H mm	L mm	
340.0001	8000	10.0	38.0	6.0	20.0	55.0	50
340.0002	10500	10.0	50.0	6.0	20.0	70.0	60
340.0003	4500	10.0	63.0	6.0	20.0	88.0	70
340.0004	4500	15.0	75.0	6.0	25.0	105.0	80
340.0005	4500	15.0	80.0	6.0	25.0	112.0	90

Rust free steel jar brush 0,3 mm

- With 6 mm mandril
- To enable with high rotary speed
- Long durability through compact border
- For use with drill machine
- For surface preparation
- Curled and rust free steel wire

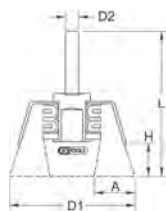

	RPM max	A mm	D1 mm	D2 mm	H mm	L mm	
340.0011	8000	10.0	38.0	6.0	20.0	55.0	50
340.0012	10500	10.0	50.0	6.0	20.0	70.0	60
340.0013	4500	10.0	63.0	6.0	20.0	88.0	70
340.0014	4500	15.0	75.0	6.0	25.0	105.0	80
340.0015	4500	15.0	80.0	6.0	25.0	112.0	90

Steel wire brush 0,3 mm

- With 6 mm mandril
- For use with drill machine
- For difficult to access areas
- For surface preparation
- Crimped steel wire



	RPM max	D1 mm	D2 mm	H mm	L mm	
340.0016	20000	17.0	6.0	22.0	65.0	30
340.0017	18000	23.0	6.0	25.0	68.0	40
340.0018	18000	30.0	6.0	25.0	68.0	50

Paint brush steel wire brush 0,5 mm

- With 6 mm mandril
- For use with drill machine
- For difficult to access areas
- For surface preparation
- Crimped steel wire



	RPM max	D1 mm	D2 mm	H mm	L mm	
340.0019	20000	17.0	6.0	22.0	65.0	30
340.0020	18000	23.0	6.0	25.0	68.0	40
340.0021	18000	30.0	6.0	25.0	68.0	40

Steel wire jar brush 0,5 mm

- Braided design
- With thread arbor
- For use in one hand angle grinder
- Ideal for heavy brush works
- For surface preparation
- Crimped steel wire



	RPM max	mm	D mm	H mm	L mm	No. plates	
340.0022	12500	M14 x 2,0	65.0	20.0	55.0	18	160
340.0023	11500	M14 x 2,0	80.0	22.0	68.0	20	200
340.0024	11500	M14 x 2,0	90.0	22.0	77.0	20	240

Rust free stainless steel wire jar brush 0,5 mm

- Braided design
- With thread arbor
- For use in one hand angle grinder
- Ideal for heavy brush works
- For surface preparation
- Curled and rust free steel wire

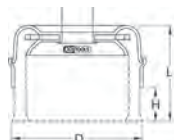

	RPM max	mm	D mm	H mm	L mm	No. plates	
340.0025	12500	M14 x 2,0	65.0	20.0	55.0	18	160
340.0026	11500	M14 x 2,0	80.0	22.0	68.0	20	200
340.0027	11500	M14 x 2,0	90.0	22.0	77.0	20	240

Steel wire brush disc 0,3 mm

- With 6 mm mandril
- Especially longlife industry version
- For use with drill machine
- For surface preparation
- Curled steel wire



	RPM max	A mm	D1 mm	D2 mm	H mm	L mm	
340.0028	20000	9.0	30.0	6.0	6.0	45.0	40
340.0029	15000	14.0	50.0	6.0	12.0	45.0	40
340.0030	15000	14.0	60.0	6.0	17.0	45.0	60
340.0031	15000	16.0	70.0	6.0	19.0	45.0	80
340.0032	15000	18.0	80.0	6.0	20.0	45.0	100

Rust free steel wire brush disc 0,3 mm

- With 6 mm mandril
- Especially longlife industry version
- For use with drill machine
- For surface preparation
- Curled and rust free steel wire

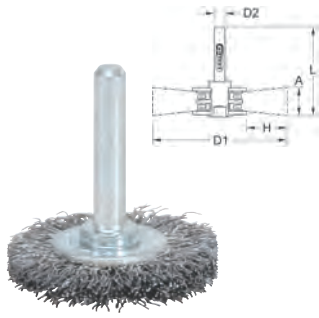

	RPM max	A mm	D1 mm	D2 mm	H mm	L mm	
340.0033	20000	9,0	30,0	6,0	6,0	45,0	40
340.0034	15000	14,0	50,0	6,0	12,0	45,0	40
340.0035	15000	14,0	60,0	6,0	17,0	45,0	60
340.0036	15000	16,0	70,0	6,0	19,0	45,0	80
340.0037	15000	18,0	80,0	6,0	20,0	45,0	100

Steel wire circular brush 0,3 mm

- Braided design
- With 6 mm mandril
- Especially longlife industry version
- For use in with drill machine
- For removing of underbody coating
- For surface preparation
- Flat steel wire

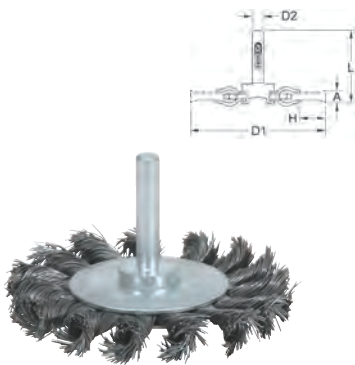

	RPM max	A mm	D1 mm	D2 mm	H mm	L mm	
340.0038	15000	12,0	75,0	6,0	15,0	43,0	100

Steel wire circular brush 0,5 mm

- Braided design
- With 6 mm mandril
- Especially longlife industry version
- For use in with drill machine
- For removing of underbody coating
- For surface preparation
- Flat steel wire



	RPM max	A mm	D1 mm	D2 mm	H mm	L mm	
340.0039	15000	12,0	75,0	6,0	15,0	43,0	100

Steel wire circular brush 0,5 mm

- Braided design
- With 22,2 mm bore reception
- Longlife industry version
- For use in one hand angle grinder
- For removing of rubber, grate and lacquer residue
- For surface preparation
- Flat steel wire

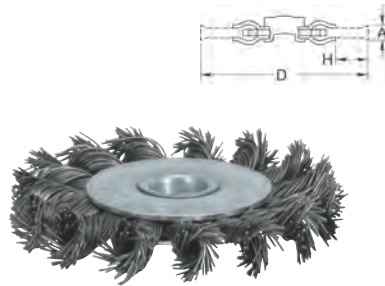

	RPM max	A mm	D mm	H mm	No. plates	
340.0040	12500	11,0	75,0	16,0	15	90
340.0041	12500	11,0	100,0	20,5	18	120
340.0042	12500	11,0	115,0	23,5	20	140
340.0043	12500	11,0	125,0	24,5	22	150

Stainless steel and brushed steel 0,5 mm

- Braided design
- With 22,2 mm bore reception
- Longlife industry version
- For use in one hand angle grinder
- For removing of rubber, grate and lacquer residue
- For surface preparation
- Flat and grate free steel wire

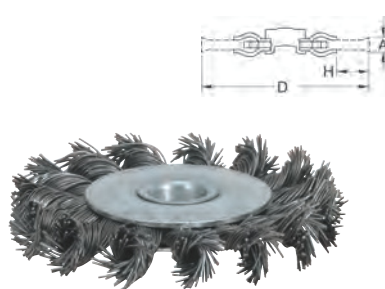

	RPM max	A mm	D mm	H mm	No. plates	
340.0044	12500	11,0	75,0	16,0	15	90
340.0045	12500	11,0	100,0	20,5	18	120
340.0046	12500	11,0	115,0	23,5	20	140
340.0047	12500	11,0	125,0	24,5	22	150

Cone design steel wire circular brush 0,5 mm

- Braided design
- With thread arbor
- Especially longlife industry version
- For use in one hand angle grinder
- For hard to reach places
- For surface preparation
- Flat steel wire



	RPM max		A mm	D mm	H mm	No. plates	
340.0048	12500	M 14 x 2,0	12,0	100,0	20,0	18	190
340.0049	15000	M 14 x 2,0	12,0	115,0	24,0	20	210

Rust free cone design steel wire circular brush 0,5 mm

- Braided design
- With thread arbor
- Especially longlife industry version
- For use in one hand angle grinder
- For hard to reach places
- For surface preparation
- Flat and grate free steel wire

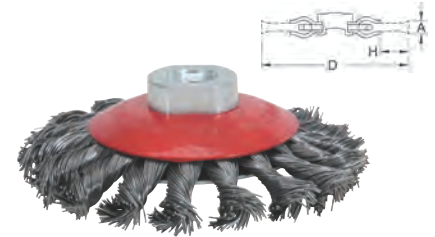

	RPM max		A mm	D mm	H mm	No. plates	
340.0050	12500	M 14 x 2,0	12,0	100,0	20,0	18	190
340.0051	15000	M 14 x 2,0	12,0	115,0	24,0	20	210

STEERING WHEEL AND FITTING

Universal steering wheel puller 3 arm

- For steering wheels with three or four spokes
- Tie rings with rubber sleeve for protection on the steering wheel
- Special steel



	Ø mm	L max mm			
670.0191	160	120	4	17	M14x1,5 x 130 1,90

Universal steering wheel puller 2 arm for passenger cars

- Suitable for quick, clean and damage-free removal of the steering wheel
- With short and long hooks as well as pressure piece for spindle
- Suitable for universal use due to longitudinal grooves in the puller bridge
- Extremely robust spindle with inductively hardened thread
- Special steel



	A mm	B mm	max mm	L mm		D mm	E mm	F mm	G mm	
670.0201	90	135	2,5	130	M14x1,5 x 130	17	5	3,5	11	7,5 900

Steering wheel distance sleeve remover for VAG

- For removing the distance sleeve on the steering spindle when changing ignition switch
- Shearing action increases the pressing power when removing
- Clamp holds hooks firm y together
- Prevents slippage
- Extremely robust spindle with inductively hardened thread
- Special steel

Application range: Audi, Volkswagen, Seat, Škoda, etc.

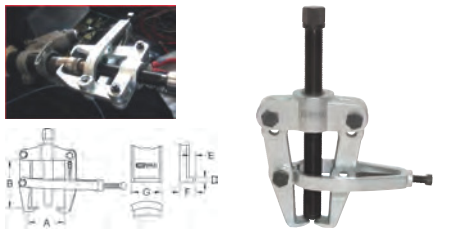

A	B	max	t	mm	D	E	F	G	kg	
mm	mm	mm	mm	mm	mm	mm	mm	mm		
620.5401	80	90	5	M18 x 1,5 x 130	19	3	12	26	24	1.70

Steering wheel distance sleeve puller for Volkswagen

- Suitable for quick, clean and damage-free removal of the adapter sleeve on the steering arm
- External drive hexagonal socket 17.0 mm
- Extremely robust spindle with inductively hardened thread
- Special steel

Application range: Volkswagen Golf 2, Golf 3, Golf 4, Jetta, Passat > 1988



Length mm	kg	
450.0303	180.0	720

Steering wheel distance sleeve mandrel

- Suitable in order to strike the adapter sleeve damage-free on the steering column
- Brass



Length mm	Ø mm	kg	
450.0304	150.0	30.0	720

Pull hook set for instrument cluster

- Ideal for removing the instrument cluster
- Without this tool it is impossible to remove the instrument cluster without damage
- Specially curved
- 1 piece handle
- With suspension hole

Application range: Mercedes W116, W123, W124, W126, W129, W140, W201, W202, W203, W208, W209, W210, W211, W220, W230, Volkswagen Crafter

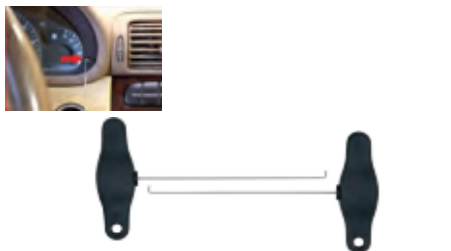

kg			
140.2380	2 pcs	Pull hook set for instrument cluster	112

consists of:

X	kg		
140.2381	2	Pull hook for headrests, 172 mm	56

Steering column shroud screwdriver for TX screws

- Suitable for assembly and disassembly of steering column shroud
- 1 piece handle
- Optimal power transmission
- With suspension hole
- Hardened blade
- Chrome finish with burnished tips
- Blade made of chrome vanadium

Application range: Audi A4 (8E), A6 (4F)

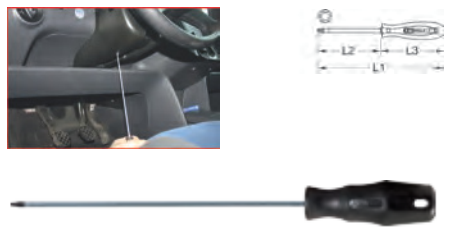

L1 mm	L2 mm	L3 mm	kg		
911.1661	T8	350.0	250.0	100.0	80

AIRBAG

Special airbag bit socket for hexagon screws

- Suitable for the assembly and disassembly of the airbag unit
- Optimal access to the airbag unit screws
- Hexagon socket
- Internal square drive to DIN 3120/ISO 1174 with ball reception
- Bit socket in custom lengths
- With press fi ted nickel plated insert bit
- For manual operation
- Matt finish
- Chrome vanadium

Application range: Audi, etc.

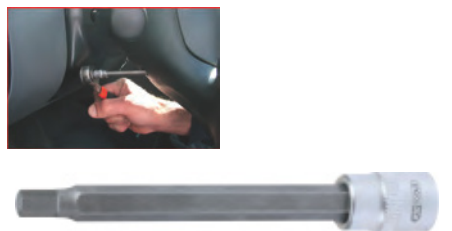

mm	Length mm	kg	
140.2303	5	85.0	30

Special airbag bit socket for TX screws

- Suitable for the assembly and disassembly of the airbag unit
- Optimal access to the airbag unit screws
- TX
- Internal square drive to DIN 3120/ISO 1174 with ball reception
- Bit socket in custom lengths
- With press fi ted nickel plated insert bit
- For manual operation
- Matt finish
- Chrome vanadium

Application range: BMW, etc.



Length mm	kg		
140.2305	T25	85.0	30

Special airbag bit socket for TX screws with bore hole

- Suitable for the assembly and disassembly of the airbag unit
- Optimal access to the airbag unit screws
- TX with bore hole
- Internal square drive to DIN 3120/ISO 1174 with ball reception
- Bit socket in custom lengths
- With press fi ted nickel plated insert bit
- For manual operation
- Matt finish
- Chrome vanadium

Application range: BMW, etc.



Length mm	kg		
140.2304	TB25	85.0	30

Special airbag bit socket for TX screws

- Suitable for the assembly and disassembly of the airbag unit
- Optimal access to the airbag unit screws
- TX
- Internal square drive to DIN 3120/ISO 1174 with ball reception
- Bit socket in custom lengths
- With press fi ted nickel plated insert bit
- For manual operation
- Matt finish
- Chrome vanadium

Application range: Audi A4 > 2004, etc.

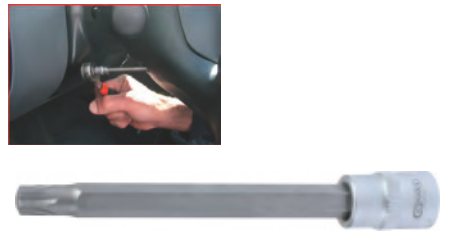

Length mm	kg		
140.2307	T27	85.0	30

Special airbag bit socket for TX screws with bore hole

- Suitable for the assembly and disassembly of the airbag unit
- Optimal access to the airbag unit screws
- TX with bore hole
- Internal square drive to DIN 3120/ISO 1174 with ball reception
- Bit socket in custom lengths
- With press fi ted nickel plated insert bit
- For manual operation
- Matt finish
- Chrome vanadium

Application range: Audi A4 > 2004, etc.

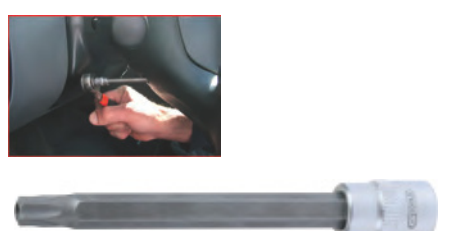

Length mm	kg		
140.2308	TB27	85.0	30

Special airbag bit socket for TX screws

- Suitable for the assembly and disassembly of the airbag unit
- Optimal access to the airbag unit screws
- TX
- Internal square drive to DIN 3120/ISO 1174 with ball reception
- Bit socket in custom lengths
- With press fi ted nickel plated insert bit
- For manual operation
- Matt finis
- Chrome vanadium

Application range: Audi, Opel, Renault, Volkswagen, etc.

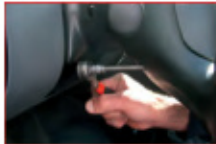

		Length mm	
140.2302	T30	85,0	30

Special airbag bit socket for TX screws with bore hole

- Suitable for the assembly and disassembly of the airbag unit
- Optimal access to the airbag unit screws
- TX with bore hole
- Internal square drive to DIN 3120/ISO 1174 with ball reception
- Bit socket in custom lengths
- With press fi ted nickel plated insert bit
- For manual operation
- Matt finis
- Chrome vanadium

Application range: Audi, BMW, Mercedes, Opel, etc.

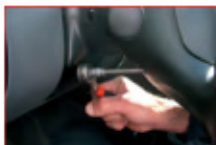

		Length mm	
140.2301	TB30	85,0	30

Special airbag bit socket set

- Suitable for the assembly and disassembly of the airbag unit
- Optimal access to the airbag unit screws
- Internal hexagon, TX with and without tamperproof borehole
- Range for the assembly and disassembly of the airbag unit
- Internal square drive to DIN 3120/ISO 1174 with ball reception
- Bit socket in custom lengths
- With press fi ted nickel plated insert bit
- For manual operation
- Matt finis
- Chrome vanadium

Application range: Audi, BMW, Mercedes, Opel, Volkswagen, etc.

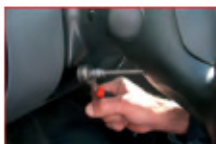

140.2300	5 pcs	Special airbag bit socket set	200

consists of:

140.2301	1/4" Airbag bit socket TB 30	30	
140.2302	1/4" Airbag bit socket TX 30	30	
140.2303	1/4" Airbag bit socket hexagonal 5 mm	30	
140.2304	1/4" Airbag bit socket TB 25	30	
140.2305	1/4" Airbag bit socket TX 25	30	

Special airbag unlocking tool

- Suitable for disassembling the airbag unit
- Optimal access to the airbag unit
- For manual operation
- 1 piece handle
- Special steel

Application range: Audi, Seat, Škoda, BMW, Mercedes, Volkswagen, etc.



140.2317	Special airbag unlocking tool	30

Special airbag key

- Suitable for disassembling the airbag unit
- Optimal access to the airbag unit
- For manual operation
- Contains 2 pieces as standard
- 1 piece handle
- Special steel

Application range: Audi A4, A6, Volkswagen Passat, Polo, Lupo, etc.



140.2313	Special airbag key	100

Special airbag key

- Suitable for disassembling the airbag unit
- Optimal access to the airbag unit
- For manual operation
- Contains 2 pieces as standard
- 1 piece handle
- Special steel

Application range: Seat, Škoda Fabia, Octavia, Volkswagen Golf 4, New Beetle, etc.



140.2311	Special airbag key	70

Special airbag unlocking tool

- Suitable for disassembling the airbag unit
- Optimal access to the airbag unit
- For manual operation
- With suspension hole
- Special steel

Application range: Volkswagen, Golf 4, Bora, Passat, etc.



140.2315	Special airbag unlocking tool	30

Special airbag removal lever

- Suitable for disassembling the airbag unit
- Optimal access to the airbag unit
- For manual operation
- Special steel

Application range: Volkswagen



	Width mm	Length mm	
140.2316	5,5 + 8,0	105,0 + 95,0	50

Airbag dismantling tool set

- For the dismantling and assembly of airbag units
- Sockets are the ideal length
- Optimal access to the reinforcement screws of the airbag pad
- Universal usage
- In durable plastic case

Application range: Audi, BMW, Mercedes Benz, Opel, Volkswagen, Renault, Seat, Skoda, etc.

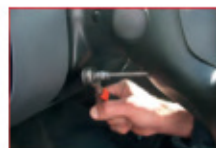

140.2310	12 pcs	Airbag dismantling tool set	1,60

consists of:

140.2301	1/4" Airbag bit socket, TB 30	30	
140.2302	1/4" Airbag bit socket, T30	30	
140.2303	1/4" Airbag bit socket, hex 5mm	30	
140.2304	1/4" Airbag bit socket, TB 25	30	
140.2305	1/4" Airbag bit socket, T25	30	
140.2311	Airbag tools Golf 4, Skoda Fabia, 2pcs	70	
140.2313	Airbag tools VW Polo, Audi A4, 2pcs	100	
140.2315	Airbag tools Golf 4, Passat, Bora	30	
140.2316	Airbag tools VW, 105x96mm 5,5+8,0mm	50	
140.2317	Uni Airbag unlocking tool	30	

LOCKING CYLINDER

Door lock screwdriver

- Splined (XZN*)
- Suitable for the assembly and disassembly of the door lock screws
- Also suitable for the external door handle
- 1 piece handle
- Blade made of chrome vanadium

Application range: Audi TT, Volkswagen Golf 4, Passat B5, Lupo, New Beetle, Bora, Seat, Škoda, etc.

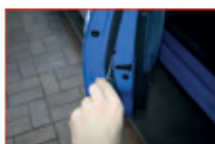

		L1 mm	L2 mm	
911.1117	M4	215.0	125.0	50

VAG ignition lock disassembly needle tool

- Suitable for disassembling the ignition lock
- For unlocking the interior locking bolt
- With two component handle
- Blade made of chrome vanadium

Application range: Audi A3, Volkswagen Golf 4, Passat >1997, Seat, etc.



	Ø mm	L1 mm	L2 mm	
911.1118	1,4	200.0	120.0	60



Mercedes steering wheel lock spring clamp

- Suitable for disassembling the protective sleeve with ignition starter switch from the steering wheel lock
- Locating bolts in the steering lock part must be pressed in with the spring clamps
- Contains 2 pieces as standard
- Special steel

Application range: Mercedes W129, W140, W210 and W202 with FBS2 ignition lock



	Length mm	Width mm	
500.1310	150.0	105.0	10

Mercedes rear lock disassembly needle tool

- Suitable for the quick removal of the locking cylinder on the rear lock
- Contains 2 pieces as standard
- Special steel

Application range: Mercedes W203 rear lock



	Length mm	
500.1311	110.0	10

Mercedes ignition lock disassembly needle tool set

- Ideal for fast disassembly of the ignition
- Easy removal
- Special steel

Application range: Mercedes W116, W123, W124, W126, W201

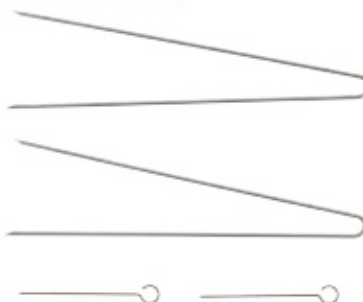

500.1315	4 pcs	Mercedes ignition lock disassembly needle tool set	25

consists of:

500.1383	Mercedes ignition removal needle tool Ø 1.25 mm, 2 pcs.	9	
500.1384	Mercedes ignition removal needle tool Ø 2.0 mm, 2 pcs.	1	

Ignition key mounting sleeve

- Suitable for the quick release of the ignition lock rosette
- With suspension hole
- Aluminium

Application range: Mercedes W129, W140, W203, W208, W209, W210, W211, W220, W230, W906 with FBS2 and FBS3 ignition lock systems, Volkswagen Crafter



	Length mm	
500.1312	80.0	55

Ignition key mounting sleeve

- Suitable for the quick release of the ignition lock rosette
- With rubber mat in the interior
- Special steel

Application range: Mercedes W202, W210 until 1997



	Length mm	
500.1313	110.0	150

Locking cylinder assembly sleeve

- Suitable for the quick and exact repair of the door lock
- For inside track closure with internal spring
- Special steel

Application range: Seat, Škoda, Volkswagen Passat, Vento, Beetle, Lupo, Golf 4 (not Cabrio), etc.



	Total length mm	
500.1314	65.0	100

RADIO AND NAVIGATION SYSTEM

Radio and navigation device unlocking tool Panasonic

- Ideal for the assembly and disassembly of car radios and navigation devices
- Professionally and without damage
- Saves time
- Contains 2 pieces as standard

Application range: for Panasonic



	Length mm	9
500.1366	100.0	6

Radio and navigation device unlocking tool Kenwood

- Ideal for the assembly and disassembly of car radios and navigation devices
- Professionally and without damage
- Saves time
- Contains 2 pieces as standard

Application range: for Kenwood > 1998



	Length mm	9
500.1367	110.0	4

Radio and navigation device unlocking tool Panasonic

- Ideal for the assembly and disassembly of car radios and navigation devices
- Professionally and without damage
- Saves time
- Contains 2 pieces as standard

Application range: for Panasonic



	Length mm	9
500.1368	105.0	5

Radio and navigation system unlocking tool Pioneer and JVC

- Ideal for the assembly and disassembly of car radios and navigation devices
- Professionally and without damage
- Saves time
- Contains 2 pieces as standard

Application range: for Pioneer and JVC



	Length mm	9
500.1369	95.0	6

Radio installation and removal set

- Ideal for the assembly and disassembly of car radios and navigation devices
- Professionally and without damage
- Saves time
- Contains 2 pieces as standard

Application range: for Blaupunkt, Grundig, Volkswagen, Audi, Ford



	Length mm	9
500.1371	96.0	22

Radio installation and removal set

- Ideal for the assembly and disassembly of car radios and navigation devices
- Professionally and without damage
- Saves time
- Contains 1 pieces as standard

Application range: for BMW



	Length mm	9
500.1372	85.0	20

Radio installation and removal set

- Ideal for the assembly and disassembly of car radios and navigation devices
- Professionally and without damage
- Saves time
- Contains 4 pieces as standard

Application range: for Audi, Volkswagen, Becker, Mercedes



	Length mm	9
500.1373	78.0	15

Radio installation and removal set

- Ideal for the assembly and disassembly of car radios and navigation devices
- Professionally and without damage
- Saves time
- Contains 2 pieces as standard

Application range: for Becker, Porsche, Mercedes



	Length mm	9
500.1374	68.0	6

Radio installation and removal set

- Ideal for the assembly and disassembly of car radios and navigation devices
- Professionally and without damage
- Saves time
- Contains 2 pieces as standard

Application range: for Volkswagen, Ford



	Length mm	9
500.1375	61.0	6

Radio installation and removal set

- Ideal for the assembly and disassembly of car radios and navigation devices
- Professionally and without damage
- Saves time
- Contains 1 pieces as standard

Application range: for BMW and Opel



	Length mm	9
500.1376	52.0	2

Radio installation and removal set

- Ideal for the assembly and disassembly of car radios and navigation devices
- Professionally and without damage
- Saves time
- Contains 2 pieces as standard

Application range: for Becker > 2002

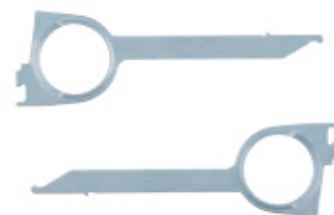

	Length mm	9
500.1377	89.0	11

Radio installation and removal set

- Ideal for the assembly and disassembly of car radios and navigation devices
- Professionally and without damage
- Saves time
- Contains 2 pieces as standard

Application range: for Škoda > 2002



	Length mm	9
500.1378	65.0	7

Radio installation and removal set

- Ideal for the assembly and disassembly of car radios and navigation devices
- Professionally and without damage
- Saves time
- Contains 4 pieces as standard

Application range: for Blaupunkt > 2002



Length mm		
500.1379	97.0	24

Radio and navigation device unlocking tool Opel

- Ideal for the assembly and disassembly of car radios and navigation devices
- Professionally and without damage
- Saves time
- Contains 2 pieces as standard

Application range: for Opel double ball hexagon socket



Length mm		
500.1381	90.0	15

Radio and navigation system unlocking tool Mercedes and BMW

- Ideal for the assembly and disassembly of car radios and navigation devices
- Professionally and without damage
- Saves time
- Contains 2 pieces as standard

Application range: for Mercedes and BMW



Length mm		
500.1382	165.0	21

Radio and navigation system unlocking tool Mercedes and BMW

- Ideal for the assembly and disassembly of car radios and navigation devices
- Professionally and without damage
- Saves time
- Contains 2 pieces as standard

Application range: for Mercedes and BMW



Length mm		
500.1383	180.0	9

Mercedes ignition removal needle tool Ø 2.0 mm

- Ideal for the assembly and disassembly of car radios and navigation devices
- Professionally and without damage
- Saves time
- Contains 2 pieces as standard

Application range: for Mercedes and BMW



Length mm		
500.1384	65.0	1

Radio and navigation device unlocking tool Clarion

- Ideal for the assembly and disassembly of car radios and navigation devices
- Professionally and without damage
- Saves time
- Contains 2 pieces as standard

Application range: for Clarion new



Length mm		
500.1385	115.0	11

Radio and navigation device unlocking tool Kenwood

- Ideal for the assembly and disassembly of car radios and navigation devices
- Professionally and without damage
- Saves time
- Contains 2 pieces as standard

Application range: for Kenwood

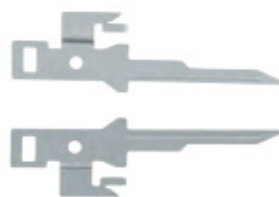

Length mm		
500.1386	110.0	9

Radio and navigation device unlocking tool Clarion

- Ideal for the assembly and disassembly of car radios and navigation devices
- Professionally and without damage
- Saves time
- Contains 2 pieces as standard

Application range: for Clarion old



Length mm		
500.1387	115.0	28

Radio and navigation device unlocking tool Kenwood

- Ideal for the assembly and disassembly of car radios and navigation devices
- Professionally and without damage
- Saves time
- Contains 2 pieces as standard

Application range: for Kenwood III > 2002



Length mm		
500.1388	120.0	7

Radio and navigation device unlocking tool Sony

- Ideal for the assembly and disassembly of car radios and navigation devices
- Professionally and without damage
- Saves time
- Contains 2 pieces as standard

Application range: for Sony II > 2002



Length mm		
500.1389	97.0	7

Radio and navigation device unlocking tool Kenwood

- Ideal for the assembly and disassembly of car radios and navigation devices
- Professionally and without damage
- Saves time
- Contains 2 pieces as standard

Application range: for Kenwood II 1998-2001



Length mm		
500.1396	120.0	7

Radio and navigation device unlocking tool Sony

- Ideal for the assembly and disassembly of car radios and navigation devices
- Professionally and without damage
- Saves time
- Contains 2 pieces as standard

Application range: for Sony I > 2005



Length mm		
500.1397	115.0	7

Radio and navigation device unlocking tool Sony

- Ideal for the assembly and disassembly of car radios and navigation devices
- Professionally and without damage
- Saves time
- Contains 2 pieces as standard

Application range: for Sony I > 2001



	Length mm	kg
500.1398	54.0	4

Radio and navigation device unlocking tool Fiat

- Ideal for the assembly and disassembly of car radios and navigation devices
- Professionally and without damage
- Saves time
- Contains 2 pieces as standard

Application range: for Fiat Brava



	Length mm	kg
500.1399	74.0	10

Radio installation and removal set

- Ideal for the assembly and disassembly of car radios and navigation devices
- For loosening the locking devices
- Range for various unlocking systems
- In plastic storage pouch



		kg
500.1370	18 pcs Radio installation and removal set	160

consists of:

		kg
500.1371	Radio install+removal set, 2pcs, FORD	22
500.1372	Radio install+removal set, 1pcs, BMW	20
500.1373	Radio install+removal set, 4pcs, Mercedes	15
500.1374	Radio install+removal set, 2pcs, Porsche	6
500.1375	Radio install+removal set, 2pcs, VW	6
500.1376	Radio install+removal set, 1pcs, BMW/OPEL	2
500.1377	Radio install+removal set, 2pcs, Becker	11
500.1378	Radio install+removal set, 2pcs, Skoda	7
500.1379	Radio install+removal set, 2pcs, Blaupunkt	24

Radio and navigation system installation and removal set

- Ideal for the assembly and disassembly of car radios and navigation devices
- For loosening the locking devices
- Extensive range for various unlocking systems
- In durable plastic storage case

Application range: Porsche, Mercedes, Fiat, Volkswagen, Audi, Ford, BMW, Opel, Clarion, Kenwood, Panasonic, Pioneer, JVC, Sony, Becker, Blaupunkt, Grundig, etc.



		kg
500.1380	52 pcs Radio and navigation system installation and removal set	1,41

consists of:

		kg
500.1366	Radio unlocking tool Panasonic, 2 pcs.	6
500.1367	Radio unlocking tool Kenwood, 2 pcs.	4
500.1368	Radio unlocking tool Panasonic, 2 pcs.	5
500.1369	Radio unlocking tool Pioneer, JVC, 2 pcs	6
500.1371	Radio install+removal set, 2pcs, FORD	22
500.1372	Radio install+removal set, 1pcs, BMW	20
500.1373	Radio install+removal set, 4pcs, Mercedes	15
500.1374	Radio install+removal set, 2pcs, Porsche	6
500.1375	Radio install+removal set, 2pcs, VW	6
500.1376	Radio install+removal set, 1pcs, BMW/OPEL	2
500.1377	Radio install+removal set, 2pcs, Becker	11
500.1378	Radio install+removal set, 2pcs, Skoda	7
500.1379	Radio install+removal set, 2pcs, Blaupunkt	24
500.1381	Radio unlocking tool Opel, 2 pcs.	15
500.1382	Radio unlocking tool, Mercedes, BMW, 2 pcs.	21
500.1383	Mercedes ignition removal needle tool Ø 1.25 mm, 2 pcs.	9
500.1384	Mercedes ignition removal needle tool Ø 2.0 mm, 2 pcs.	1
500.1385	Radio unlocking tool Clarion, 2 pcs.	11
500.1386	Radio unlocking tool Kenwood, 2 pcs.	9
500.1387	Radio unlocking tool Clarion, 2 pcs.	28
500.1388	Radio unlocking tool Kenwood, 2 pcs.	7
500.1389	Radio unlocking tool Sony, 2 pcs.	7
500.1396	Radio unlocking tool Kenwood, 2 pcs.	7
500.1397	Radio unlocking tool Sony, 2 pcs.	7
500.1398	Radio unlocking tool Sony, 2 pcs.	4
500.1399	Radio unlocking tool Fiat, 2 pcs.	10

CLIP, RIVET AND EXTRACTION TOOLS

Plastic rivet pliers set included rivets

- Suitable for plastic rivets
- Narrow head pliers
- Can be used in hard to access areas
- 90° angled rivet head
- With rubber grip
- Includes 40 plastic rivets
- Die-cast metal body

Plastic rivets: 5.0x15.8 - 5.0x17.2 - 6.3x25.2 - 6.8x17.2 mm

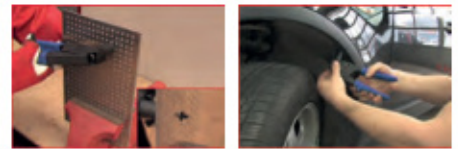

		kg
150.9650	41 pcs Plastic rivet pliers set included rivets	760

consists of:

		kg
150.9651	Plastic rivet pliers	580
150.9652	Replacement rivets Pack of 10, 17.2 x 6.6 mm	20
150.9653	Replacement rivets Pack of 10, 25.2 x 6.3 mm	22
150.9654	Replacement rivets Pack of 10, 17.2 x 5 mm	15
150.9655	Replacement rivets Pack of 10, 15.8 x 5 mm	16

Rivet removal pliers set

- Suited to the dismantling of plastic rivets
- Self-opening
- Including angled and straight set up
- Plastic



		kg
115.1096	2 pcs Rivet removal pliers set	40

consists of:

		kg
115.1097	Rivet pliers, red, angled, 100mm	20
115.1098	Rivet pliers, blue, straight, 100mm	20

Trim clip pliers set

- Suited to the dismantling of plastic rivets and plastic clips
- With various profiles
- 35° + 80° angled tips
- Self-opening
- Chrome vanadium

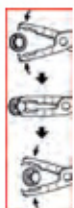

115.1086	2 pcs	Trim clip pliers set	380
----------	-------	----------------------	-----

consists of:

115.1087	Trim clip pliers, 35° offset, 190mm	180
115.1088	Trim clip pliers, 80° offset, 200mm	190

Clip remover

- For metal and plastic clips
- Durable tool for the removal of door panels
- Lever effect due to the angled head on the front end of the lifter
- Robust execution with durable square shaft
- With hanging hole
- Special steel



	L mm	
911.8150	300.0	190

Clip remover, short

- For metal and plastic clips
- Durable tool for the removal of door panels
- Lever effect due to the angled head on the front end of the lifter
- Rugged design with durable shaft
- With suspension hole
- 15° angled
- With two component handle
- Special steel



	L mm	opening mm	
140.2371	245.0	4.0	65
140.2372	245.0	8.0	65
140.2373	245.0	10.0	65

Clip remover, long

- For metal and plastic clips
- Durable tool for the removal of door panels
- Lever effect due to the angled head on the front end of the lifter
- Rugged design with durable shaft
- With suspension hole
- 15° angled
- With two component handle
- Special steel



	L mm	opening mm	
140.2374	510.0	4.0	150
140.2375	510.0	8.0	150
140.2376	510.0	10.0	150

Clip removal set

- For metal and plastic clips
- Durable tool for the removal of door panels
- Lever effect due to the angled head on the front end of the lifter
- Rugged design with durable shaft
- With suspension hole
- 15° angled
- With two component handle
- Special steel



140.2370	6 pcs	Clip removal set	1.00
----------	-------	------------------	------

consists of:

140.2371	Clip release short, length 245 mm, opening 4 mm	65	
140.2372	Clip release short, length 245 mm, opening 8 mm	65	
140.2373	Clip release short, length 245 mm, opening 10 mm	65	
140.2374	Clip release long, length 510 mm, opening 4 mm	150	
140.2375	Clip release long, length 510 mm, opening 8 mm	150	
140.2376	Clip release long, length 510 mm, opening 10 mm	150	

Clip remover

- For removing and installing clips
- With varying length ends
- Very flared and robust execution
- Painted surface
- Metal



	L1 mm	L2 mm	L3 mm	
140.2249	230.0	100.0	50.0	170

Clip removal set

- Special tool for the careful removal of metal and plastic clips and Rubber plugs
- Straight and angled form
- With rubber handle
- Metal



140.2232	2 pcs	Clip removal set	90
----------	-------	------------------	----

consists of:

140.2223	Clip remover angled form	45	
140.2224	Clip remover straight form	45	

Standard clip remover

- With wedge shaped end
- With lifting and wedge function
- Ideal for loosening panels without damage to the paintwork
- Special plastic



	L mm	B mm	
911.8125	210.0	20.0	80

Double clip remover

- With wedge shaped end
- Very robust execution
- With 2 different lever angles at 75° and 30°
- Special plastic



	L mm	B mm	
911.8123	200.0	30.0	70

Clip remover with pulling eye

- With wedge shaped end
- Pulling eye for removal
- With 90° angled side
- Ideal for loosening panels without damage to the paintwork
- Special plastic



	L mm	B mm	
911.8124	180.0	30.0	70

Plastic lever wedge set

- Ideal for loosening miscellaneous cover parts
- Practical assortment of different wedge and clip removal tools
- Slim and robust design
- Ideal for avoiding paint damage and damage-free release of interior trims, panels, etc.
- For delicate work on fragile cover parts
- Special plastic



911.8120	5 pcs	Plastic lever wedge set	300
----------	-------	-------------------------	-----

consists of:

		
911.8121	Bumper trim removal wedge, 160 mm	80
911.8122	Trim removal wedge, 180 mm	40
911.8123	Double clip wedge, with wedge shaped end, 200 mm	70
911.8124	Clip lever, with wedge shaped end, 180 mm	70
911.8125	Standard clip wedge, with wedge shaped end, 210 mm	80

Dual clip remover, offset

- Flat shaped back
- Durable design
- With straight- and sharp chisel end
- Ideal for loosening panels without damage to the paintwork
- With hanging hole
- Special plastic



	L mm	B mm	
911.8106	200.0	30.0	40

Dual clip remover, straight profile

- Flat shaped back
- Durable design due to straight profil
- Blunt chisel end
- Ideal for loosening panels without damage to the paintwork
- With hanging hole
- Special plastic



	L mm	B mm	
911.8107	200.0	30.0	40



Clip remover U-form, narrow angled

- Universal usage
- For removing cover panels trims and protective caps, etc
- Beveled ground blades
- With hanging hole
- With two component handle
- Stainless steel



	Width mm	Depth mm	Total length mm	Blade thickness mm	
911.8191	6.0	13.0	230.0	95.0	120

Clip remover V-form

- Universal usage
- For removing cover panels trims and protective caps, etc
- With cutting edge blade
- Bevelled ground cutting edge blade
- With hanging hole
- With two component handle
- Stainless steel



	Width mm	Depth mm	Total length mm	Blade thickness mm	
911.8192	5.0	8.0	230.0	95.0	120

Clip remover U-form, wide offset

- Universal usage
- For removing cover panels trims and protective caps, etc
- Bevelled ground blades
- With hanging hole
- With two component handle
- Stainless steel



	Width mm	Depth mm	Total length mm	Blade thickness mm	
911.8193	8.0	20.0	260.0	120.0	210

Clip remover U-form, wide angled

- Universal usage
- For removing cover panels trims and protective caps, etc
- Beveled ground blades
- With hanging hole
- With two component handle
- Stainless steel



	Width mm	Depth mm	Total length mm	Blade thickness mm	
911.8194	16.0	20.0	230.0	95.0	150

Clip remover Y-form, double width angled

- Universal usage
- For removing cover panels trims and protective caps, etc
- Bevelled ground blades
- With hanging hole
- With two component handle
- Stainless steel



	Width mm	Depth mm	Total length mm	Blade thickness mm	
911.8195	8.0	20.0	230.0	95.0	150

Clip remover and cutting set

- Universal use due to different blades
- For removing cover panels trims and protective caps, etc
- Bevelled ground blades
- With hanging hole
- With two component handle
- Stainless steel

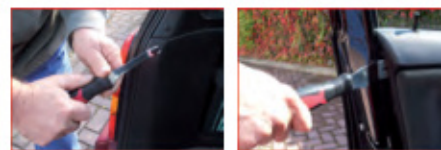

		
911.8190	5 pcs Clip remover and cutting set	2.00

consists of:

		
911.8191	Clip remover U-form, narrow angled, 230 mm	120
911.8192	Clip remover V form, 230 mm	120
911.8193	Clip release U-form, wide offset, 230 mm	210
911.8194	Clip release U-form, wide angled, 230 mm	150
911.8195	Clip release Y form, double width angled, 230 mm	150

FASTENING CLIPS FOR ALFA ROMEO

Trim clip

- for Fiat
- for Alfa Romeo
- in poly bag



Content	Head Ø mm	Length mm	Ø mm	OE	Icon
420.1208	10	18.5	18.5	14188282, 46306526, 60507749	10
420.5208	50	18.5	18.5	14188282, 46306526, 60507749	51

FASTENING CLIPS FOR AUDI

Door panel clip

- for Audi
- for Volkswagen
- in poly bag



Content	Head Ø mm	Length mm	Ø mm	OE	Icon
420.1010	10	22.0	10.0	3B0838243, 3B0868243	18
420.5010	50	22.0	10.0	3B0838243, 3B0868243	91

Push-type clip

- for Audi
- for Volkswagen
- in poly bag



Content	Head Ø mm	Length mm	Ø mm	OE	Icon
420.1001	10	24.0	15.0	1H0867199A, 51481915964	18
420.5001	50	24.0	15.0	1H0867199A, 51481915964	89

Car interior lining connection clip

- for Audi
- for Volkswagen
- in poly bag



Content	Head Ø mm	Length mm	OE	Icon	
420.1002	10	28.3	31.3	1H086243, 1H0868243B	38
420.5002	50	28.3	31.3	1H086243, 1H0868243B	192

Side moulding rubber

- for Audi
- for Citroën/Peugeot
- in poly bag



Content	Head Ø mm	Length mm	Ø mm	OE	Icon
420.1653	10	17.7	21.8	357853575, 6991W4	13
420.5653	50	17.7	21.8	357853575, 6991W4	64

Connection rubber seal

- for Audi
- for Volkswagen
- for Škoda
- in poly bag



Content	Width mm	OE	Icon
420.1003	10	1H0853585A	31
420.5003	50	1H0853585A	157

Connection rubber seal

- for Audi
- for Volkswagen
- in poly bag

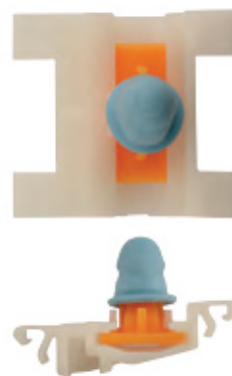

Content	Width mm	OE	Icon
420.1004	10	3A0853575	75
420.5004	50	3A0853575	374

Connection rubber seal

- for Audi
- for Volkswagen
- in poly bag



Content	Head Ø mm	Width mm	Ø mm	OE	Icon
420.1005	10	18.0	21.0	3B0853575	16
420.5005	50	18.0	21.0	3B0853575	78

Fastening clip

- for Audi
- for Volkswagen
- in poly bag



Content	Head Ø mm	Length mm	Ø mm	OE	Icon
420.1006	10	16.0	12.0	3A0853575, 3A0853575A	14
420.5006	50	16.0	12.0	3A0853575, 3A0853575A	70

Plastic fastening clip

- for Audi
- for Volkswagen
- in poly bag



Content	Width mm	Length mm	OE	
420.1007	10	25.2	4A0853825C	26
420.5007	50	25.2	4A0853825C	131

Plastic clip

- for Audi
- for Volkswagen
- in poly bag



Content	Width mm	Length mm	OE	
420.1864	10	21.9	4A0853825, 4A0853825A	23
420.5864	50	21.9	4A0853825, 4A0853825A	115

Extraction hood support

- for Audi
- for Seat
- in poly bag



Content	Head Ø mm	Width mm	Length mm	OE	
420.1008	10	27.6	16.0	1H0823397	20
420.5008	50	27.6	16.0	1H0823397	99

Push-type clip

- for Audi
- in poly bag



Content	Head Ø mm	Length mm	Ø mm	OE	
420.1009	10	23.0	29.0	1H0819055C01C	18
420.5009	50	23.0	29.0	1H0819055C01C	88

Door strip fastening

- for Audi
- for Volkswagen
- in poly bag



Content	Width mm	Length mm	OE		
420.1011	10	8.1	31.0	6U085733	8
420.5011	50	8.1	31.0	6U085733	38

Fastening clip

- for Audi
- for Citroën/Peugeot
- in poly bag



Content	Head Ø mm	Length mm	Ø mm	OE	
420.1012	10	17.8	17.3	357853575, 95667895	11
420.5012	50	17.8	17.3	357853575, 95667895	54

Drive-in connection clip

- for Audi
- for Volkswagen
- in poly bag



Content	Post Ø mm	Ø (mm)	OE		
420.1013	10	4.5	7.5	6N0823397C	17
420.5013	50	4.5	7.5	6N0823397C	87

Plastic nut clip

- for Audi
- in poly bag



Content	Head Ø mm	Ø mm	OE		
420.1016	10	15.5	7.5	N90821401	9
420.5016	50	15.5	7.5	N90821401	43

Motor protection/bumper clip

- for Audi
- for Volkswagen
- in poly bag



Content	Head Ø mm	Length mm	OE		
420.1017	10	25.0	27.8	4A0805121C	22
420.5017	50	25.0	27.8	4A0805121C	112

Trim clip

- for Audi
- for Skoda
- in poly bag



Content	Head Ø mm	Ø mm	OE	
420.1018	10	21.0	703867299	8
420.5018	50	21.0	703867299	39

Quick-release fastener

- for Audi
- for Volkswagen
- for Seat
- in poly bag



Content	Ø mm	OE	
420.1015	10	32.0 N90796501	22
420.5015	50	32.0 N90796501	112

Connection clip

- for Audi
- for Volkswagen
- in poly bag



Content	Head Ø mm	Length mm	Ø mm	OE	
420.1862	10	27.0	30.0	1H0868243B	40
420.5862	50	27.0	30.0	1H0868243B	202

Bumper grommet

- for Audi
- in poly bag



Content	Head Ø mm	Length mm	Ø mm	OE	
420.1019	10	13.0	12.7	1H0853586	5
420.5019	50	13.0	12.7	1H0853586	26



UNIVERSAL FASTENING CLIPS ALSO FOR AUDI

Screw grommet

- for Audi
- for Volkswagen
- in poly bag



Content	Head Ø mm	Length mm	Screw mm	OE	
420.1863	10	15.0	12.0	N90833801	6
420.5863	50	15.0	12.0	N90833801	32

Boot interior lining clip

- for Audi
- in poly bag



Content	Head Ø mm	Ø mm	OE	
420.1020	10	13.8	8.0 80186729901C	8
420.5020	50	13.8	8.0 80186729901C	40

Drive-in connection clip

- for Audi
- for Citroën/Peugeot
- for Opel
- for Volkswagen
- in poly bag



Content	Head Ø mm	Length mm	Ø mm	OE	
420.1857	10	12.3	17.5	7814.24, N0385501	6
420.5857	50	12.3	17.5	7814.24, N0385501	30

Connection clip

- for Audi
- for Volkswagen
- in poly bag



Content	Head Ø mm	Length mm	Ø mm	OE	
420.1865	10	22.0	25.0	3B0853576	25
420.5865	50	22.0	25.0	3B0853576	124

Plastic connection nuts

- for Audi
- for Volkswagen
- in poly bag



Content	Head Ø mm	Length mm	Ø mm	OE	
420.1860	10	14.1	10.3	171201969	8
420.5860	50	14.1	10.3	171201969	41



Plastic screw

- for Audi
- for Volkswagen
- in poly bag



	Content	Head Ø mm	Length mm	Ø mm	OE		
	420.1869	10	20,0	15,0	10,0	191941142	7
	420.5869	50	20,0	15,0	10,0	191941142	37

Connection clip

- for Audi
- for Citroën/Peugeot
- for Opel
- for Volkswagen
- in poly bag



	Content	Head Ø mm	Length mm	Ø mm	OE		
	420.1604	10	18,0	20,0	8,2	2345959, 7701053516, 7L5853994	9
	420.5604	50	18,0	20,0	8,2	2345959, 7701053516, 7L5853994	43

Quick-release fastener

- for Audi
- for Citroën/Peugeot
- for Opel
- for Volkswagen
- in poly bag



	Content	Ø mm	OE	
	420.1014	10	N90335004, N90335006	24
	420.5014	50	N90335004, N90335006	119

FASTENING CLIPS FOR BMW

Clamping nut

- for BMW
- in poly bag



	Content	Head Ø mm	Length mm	Ø mm	OE		
	420.1056	10	15,5	14,4	7,0	51311802258	5
	420.5056	50	15,5	14,4	7,0	51311802258	24

Connection clip

- for BMW
- for Volvo
- in poly bag



	Content	Head Ø mm	Length mm	Ø mm	OE		
	420.1057	10	18,0	8,0	7,0	51131804205	6
	420.5057	50	18,0	8,0	7,0	51131804205	31

Bumper lining clip

- for BMW
- in poly bag



	Content	Head Ø mm	Length mm	Ø mm	OE		
	420.1052	10	20,0	17,0	6,3	51118174185	9
	420.5052	50	20,0	17,0	6,3	51118174185	43

Push-type connection clip

- for BMW
- in poly bag



	Content	Head Ø mm	Length mm	Ø mm	OE		
	420.1058	10	19,8	9,0	6,6	51481938725	12
	420.5058	50	19,8	9,0	6,6	51481938725	62

Car interior lining clip

- for BMW
- in poly bag



	Content	Head Ø mm	Length mm	Ø mm	OE		
	420.1053	10	18,0	14,0	9,0	703867299, 823867299	8
	420.5053	50	18,0	14,0	9,0	703867299, 823867299	39

Push-type connection clip

- for BMW
- in poly bag



	Content	Width mm	Length mm	OE		
	420.1059	10	22,0	35,0	51131960054	23
	420.5059	50	22,0	35,0	51131960054	113

Metal screw/washer

- for BMW
- in poly bag



	Content	Head Ø mm	Length mm	Ø mm	OE		
	420.1908	10	20,9	17,3	9,4	07147129160	55
	420.5908	50	20,9	17,3	9,4	07147129160	275



Plastic fastening clip

- for BMW
- in poly bag



Part no.	Center mm	Head Ø mm	Length mm	Ø mm	OE	QTY
420.1054	10	16.0	11.0	4,4	16131176747	12
420.5054	50	16.0	11.0	4,4	16131176747	58

Drive-in rivet

- for BMW
- for Mercedes
- in poly bag



Part no.	Center mm	Head Ø mm	Length mm	Ø mm	OE	QTY
420.1060	10	20.0	15.0	8.0	2019900292, 30820141, 81471911992	15
420.5060	50	20.0	15.0	8.0	2019900292, 30820141, 81471911992	75

Screw-in rivets

- for BMW
- in poly bag



Part no.	Center mm	Head Ø mm	Length mm	Ø mm	OE	QTY
420.1067	10	15.0	7.0	7.0	51131885399	4
420.5067	50	15.0	7.0	7.0	51131885399	20

Plastic rivet for glove compartment

- for BMW
- for Citroën/Peugeot
- for Volkswagen
- in poly bag



Part no.	Center mm	Head Ø mm	Length mm	Ø mm	OE	QTY
420.1061	10	10.0	12.0	6.0	51161881149, 7703072116, N10259301	5
420.5061	50	10.0	12.0	6.0	51161881149, 7703072116, N10259301	24

Door trim clip

- for BMW
- in poly bag



Part no.	Center mm	Head Ø mm	Length mm	Ø mm	OE	QTY
420.1062	10	18.0	14.0	8,2	51411973500	12
420.5062	50	18.0	14.0	8,2	51411973500	59

Door trim clip

- for BMW
- in poly bag



Part no.	Center mm	Head Ø mm	Length mm	Ø mm	OE	QTY
420.1064	10	18.0	14.0	8,2	51418224768	12
420.5064	50	18.0	14.0	8,2	51418224768	59



Plastic fastening clip

- for BMW
- in poly bag

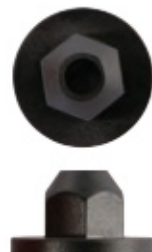

Part no.	Center mm	Head Ø mm	Length mm	Ø mm	OE	QTY
420.1055	10	18.4	11.0	4,5	51711958025	11
420.5055	50	18.4	11.0	4,5	51711958025	54

Blind rivet connection clip

- for BMW
- in poly bag



Part no.	Center mm	Length mm	Ø mm	OE	QTY
420.1051	10	51.0	6.0	51717002953	16
420.5051	50	51.0	6.0	51717002953	80

Bumper/door skills clip

- for BMW
- in poly bag



Part no.	Center mm	Head Ø mm	OE	QTY
420.1065	10	24.0	7131480419	30
420.5065	50	24.0	7131480419	148

Bumper clip

- for BMW
- in poly bag



Content	Head Ø mm	Length mm	Ø mm	OE	
420.1063	10	20,0	15,0	7887508000	16
420.5063	50	20,0	15,0	7887508000	79

Carpeting fastening clip

- for BMW
- in poly bag



Content	Head Ø mm	Length mm	OE		
420.1066	10	18,5	25,0	82119410191	20
420.5066	50	18,5	25,0	82119410191	99

Fastening clip

- for BMW
- in poly bag



Content	Head Ø mm	Ø mm	OE		
420.1068	10	13,3	6,3	51471840961	4
420.5068	50	13,3	6,3	51471840961	19

Fastening clip

- for BMW
- in poly bag



Content	Head Ø mm	Ø mm	OE		
420.1069	10	19,1	11,2	51418172050	8
420.5069	50	19,1	11,2	51418172050	38

UNIVERSAL FASTENING CLIPS ALSO FOR BMW

Metal screw/washer

- for BMW
- for Mercedes
- in poly bag



Content	Head Ø mm	Length mm	Ø mm	OE	
420.1464	10	10,8	18,8	07119916946, N914031006203	81
420.5464	50	10,8	18,8	07119916946, N914031006203	404

Cable harness connection clip

- for BMW
- for Opel
- in poly bag



Content	Head Ø mm	Length mm	Ø mm	OE	
420.1373	10	18,0	27,6	10124502	9
420.5373	50	18,0	27,6	10124502	43

Cable harness fastening

- for BMW
- for Opel
- for Volkswagen
- in poly bag



Content	Head Ø mm	Length mm	Ø mm	OE	
420.1856	10	20,3	20,2	2207713, 514719044317, N9020180H	13
420.5856	50	20,3	20,2	2207713, 514719044317, N9020180H	63

Wheel housing clip

- for BMW
- in poly bag



Content	Head Ø mm	Length mm	Ø mm	OE	
420.1871	10	20,9	17,3	07132757821	13
420.5871	50	20,9	17,3	07132757821	66

FASTENING CLIPS FOR CHRYSLER

Plastic rivet

- for Ford
- for Chrysler
- in poly bag



Content	Length mm	Ø mm	OE		
420.1276	10	54,0	6,3	6503860, N804675S	19
420.5276	50	54,0	6,3	6503860, N804675S	96

Bonnet stripped insulation fastening

- for Mitsubishi
- for Chrysler
- in poly bag



Content	Head Ø mm	Length mm	Ø mm	OE		
420.1504	10	26,0	8,0	10,0	M8020923	9
420.5504	50	26,0	8,0	10,0	M8020923	45

Blind rivet connection clip

- for Chrysler
- in poly bag



Content	Length mm	Ø mm	OE	Icon
420.1104	10	52.0	25524005	15
420.5104	50	52.0	25524005	76

Door-panel clip

- for Chrysler
- in poly bag



Content	Head Ø mm	Length mm	Ø (Ø1)	OE	Icon	
420.1101	10	19.2	18.6	7,8	6033862	9
420.5101	50	19.2	18.6	7,8	6033862	46

Boot interior lining clip

- for Citroën/Peugeot
- for Chrysler
- in poly bag



Content	Head Ø mm	Ø (mm)	OE	Icon
420.1661	10	20.0	8,0 856548, 856553	7
420.5661	50	20.0	8,0 856548, 856553	33

Engine bonnet sealing clip

- for Chrysler
- in poly bag



Content	Head Ø mm	Length mm	Ø mm	OE	Icon	
420.1105	10	29.3	12.8	8,7	4878883AA	10
420.5105	50	29.3	12.8	8,7	4878883AA	48

Blind rivet connection clip

- for Chrysler
- in poly bag



Content	Length mm	Ø mm	OE	Icon	
420.1103	10	51.8	5,1	6500898	9
420.5103	50	51.8	5,1	6500898	47

Engine bonnet clip

- for Citroën/Peugeot
- for Renault
- for Chrysler
- in poly bag



Content	Head Ø mm	Ø (mm)	OE	Icon	
420.1151	10	19.8	8,6	856553	16
420.5151	50	19.8	8,6	856553	79

Cable harness fastening

- for Chrysler
- in poly bag



Content	Head Ø mm	Length mm	Ø mm	OE	Icon	
420.1901	10	24.4	18.0	7,8	6003423	11
420.5901	50	24.4	18.0	7,8	6003423	53

Door and window rubber clip

- for Opel
- for Chrysler
- in poly bag



Content	Head Ø mm	Length mm	Ø (Ø1)	OE	Icon	
420.1102	10	10.0	11.7	6,0	20699808, 6502328	3
420.5102	50	10.0	11.7	6,0	20699808, 6502328	13

Cable harness fastening

- for Ford
- for Volkswagen
- for Chrysler
- in poly bag



Content	Head Ø mm	Length mm	Ø mm	OE	Icon	
420.1852	10	24.3	18.0	7,9	385661, 6003349, N989022	10
420.5852	50	24.3	18.0	7,9	385661, 6003349, N989022	51

Door strip fastening

- for Opel
- for Volkswagen
- for Chrysler
- in poly bag



Context	Head Ø mm	Length mm	Ø mm	OE	QTY
420.1851	10	24.2	18.5	6003349, 9685057, N98905101	14
420.5851	50	24.2	18.5	6003349, 9685057, N98905101	71

Push-type clip

- for Opel
- for Chrysler
- in poly bag



Context	Head Ø mm	Length mm	Ø mm	OE	QTY
420.1301	10	17.3	13.5	14019205, 34201621	11
420.5301	50	17.3	13.5	14019205, 34201621	53

Blind rivet connection clip

- for Opel
- for Chrysler
- in poly bag



Context	Length mm	Ø mm	OE	QTY	
420.1304	10	46.0	5.1	204655395, 6004212	7
420.5304	50	46.0	5.1	204655395, 6004212	34

Push-type clip

- for Ford
- for Opel
- for Chrysler
- in poly bag



Context	Head Ø mm	Length mm	Ø mm	OE	QTY
420.1254	10	17.8	17.5	10139822, 1673046, 6508197AA	9
420.5254	50	17.8	17.5	10139822, 1673046, 6508197AA	46

Push-type clip

- for Ford
- for Chrysler
- in poly bag



Context	Head Ø mm	Length mm	Ø mm	OE	QTY
420.1255	10	15.5	22.8	1007932, 6502871	10
420.5255	50	15.5	22.8	1007932, 6502871	50

Bumper connection clip

- for Opel
- for Chrysler
- in poly bag



Context	Head Ø mm	Length mm	Ø mm	OE	QTY
420.1308	10	21.0	25.0	10140480, 6502625	22
420.5308	50	21.0	25.0	10140480, 6502625	109

Air baffle connection clip

- for Opel
- for Chrysler
- in poly bag



Context	Head Ø mm	Length mm	Ø mm	OE	QTY
420.1311	10	20.0	20.0	21030249, 6503598&	18
420.5311	50	20.0	20.0	21030249, 6503598&	91

Bonnet stripped insulation fastening

- for Ford
- for Chrysler
- in poly bag



Context	Head mm	Length mm	Ø mm	OE	QTY
420.1256	10	12.7	40.0	385330, 6003351	13
420.5256	50	12.7	40.0	385330, 6003351	67

Car interior lining clip

- for Opel
- for Chrysler
- in poly bag



Context	Head Ø mm	Length mm	Ø mm	OE	QTY
420.1315	10	14.5	17.5	4005099, 6033862, 796255	11
420.5315	50	14.5	17.5	4005099, 6033862, 796255	53

Tail light connection clip

- for Ford
- for Opel
- for Chrysler
- in poly bag



Content	Head Ø mm	Length mm	Ø mm	OE	
420.1316	10	7.0	12.1	16500308, 6500787	4
420.5316	50	7.0	12.1	16500308, 6500787	19

Plastic rivet

- for Volkswagen
- for Chrysler
- in poly bag



Content	Length mm	Ø mm	OE	
420.1870	10	47.7	1758535570C, 6503800	9
420.5870	50	47.7	1758535570C, 6503800	46

Plastic rivet

- for Ford
- for Opel
- for Chrysler
- in poly bag



Content	Length mm	Ø mm	OE	
420.1275	10	55.5	14063981, 6500911, N8030433	18
420.5275	50	55.5	14063981, 6500911, N8030433	88

FASTENING CLIPS FOR CITROËN/PEUGEOT

Push-type clip

- for Citroën/Peugeot
- for Mercedes
- for Volvo
- in poly bag



Content	Head Ø mm	Length mm	Ø mm	OE	
420.1651	10	10.0	7.0	790307216, 947098, A0009903492	3
420.5651	50	10.0	7.0	790307216, 947098, A0009903492	15

Car interior lining clip

- for Citroën/Peugeot
- in poly bag



Content	Head Ø mm	Length mm	Ø mm	OE	
420.1652	10	18.0	13.0	856535	8
420.5652	50	18.0	13.0	856535	42

Side moulding rubber

- for Audi
- for Citroën/Peugeot
- in poly bag



Content	Head Ø mm	Length mm	Ø mm	OE	
420.1653	10	17.7	21.8	357853575, 6991W4	13
420.5653	50	17.7	21.8	357853575, 6991W4	64

Connection clip

- for Citroën/Peugeot
- in poly bag



Content	Head Ø mm	Length mm		
420.1655	10	18.0	25.2	13
420.5655	50	18.0	25.2	67

Connection clip

- for Citroën/Peugeot
- in poly bag



Content	Head Ø mm	Length mm	Ø mm	OE		
420.1656	10	18.0	16.5	9.3	694143	8
420.5656	50	18.0	16.5	9.3	694143	40

Connection clip

- for Citroën/Peugeot
- in poly bag



Content	Head Ø mm	Length mm	Ø mm	OE		
420.1657	10	20.6	24.0	7.0	743707	8
420.5657	50	20.6	24.0	7.0	743707	42



Plastic clamping nuts

- for Citroën/Peugeot
- for Mercedes
- for Renault
- in poly bag



Content	Head Ø mm	Length mm	Ø mm	OE	
420.1452	10	16.3	16.7	7703074022, A108980027	5
420.5452	50	16.3	16.7	7703074022, A108980027	26

Insert connection clip

- for Citroën/Peugeot
- for Fiat
- for Renault
- in poly bag



Content	Head Ø mm	Length mm	Ø mm	OE	
420.1701	10	16.8	11.0	14188380, 7703077059	7
420.5701	50	16.8	11.0	14188380, 7703077059	36

Clip buckle

- for Citroën/Peugeot
- in poly bag



Content	Head Ø mm	Length mm	Ø mm	OE	
420.1654	10	20.6	24.0	698317	16
420.5654	50	20.6	24.0	698317	82

Trim clip

- for Citroën/Peugeot
- in poly bag



Content	Head Ø mm	Length mm	Ø mm	OE	
420.1658	10	16.4	20.9	6,7 699502	12
420.5658	50	16.4	20.9	6,7 699502	62

Trim clip

- for Citroën/Peugeot
- in poly bag



Content	Head Ø mm	Length mm	Ø mm	OE	
420.1659	10	14.7	14.0	11,5 6995X3	8
420.5659	50	14.7	14.0	11,5 6995X3	39

Trim clip

- for Citroën/Peugeot
- in poly bag



Content	Head Ø mm	Length mm	Ø mm	OE	
420.1660	10	10.0	16.5	8,1 69945	6
420.5660	50	10.0	16.5	8,1 69945	31

UNIVERSAL FASTENING CLIPS ALSO FOR CITROËN/PEUGEOT

Fastening clip

- for Audi
- for Citroën/Peugeot
- in poly bag



Content	Head Ø mm	Length mm	Ø mm	OE	
420.1012	10	17.8	17.3	357853575, 95667895	11
420.5012	50	17.8	17.3	357853575, 95667895	54

Engine bonnet clip

- for Citroën/Peugeot
- for Renault
- for Chrysler
- in poly bag



Content	Head Ø mm	Ø mm	OE	
420.1151	10	19.8	8,6 856553	16
420.5151	50	19.8	8,6 856553	79

Drive-in connection clip

- for Audi
- for Citroën/Peugeot
- for Opel
- for Volkswagen
- in poly bag



Content	Head Ø mm	Length mm	Ø mm	OE	
420.1857	10	12.3	17.5	8,4 7814.24, N0385501	6
420.5857	50	12.3	17.5	8,4 7814.24, N0385501	30

Plastic rivet for glove compartment

- for BMW
- for Citroën/Peugeot
- for Volkswagen
- in poly bag



Content	Head Ø mm	Length mm	Ø mm	OE	
420.1061	10	10.0	12.0	6,0 51161881149, 7703072116, N10259301	5
420.5061	50	10.0	12.0	6,0 51161881149, 7703072116, N10259301	24

Door trim clip

- for Citroën/Peugeot
- for Renault
- for Chrysler
- in poly bag



Content	Head Ø mm	Ø mm	OE	
420.1704	10	18.0	09409083085ES, 699636	9
420.5704	50	18.0	09409083085ES, 699636	46



Boot interior lining clip

- for Citroën/Peugeot
- for Mercedes
- in poly bag



Content	Head Ø mm	Ø mm	OE	
420.1465	10	20.0	1239900292, 781324	11
420.5465	50	20.0	1239900292, 781324	57

Boot interior lining clip

- for Citroën/Peugeot
- in poly bag



Content	Head Ø mm	Ø mm	OE	
420.1661	10	20.0	856548, 856553	7
420.5661	50	20.0	856548, 856553	33

Push-type clip

- for Citroën/Peugeot
- for Renault
- for Chrysler
- in poly bag



Content	Head Ø mm	Ø mm	OE	
420.1705	10	36.0	7518N8, 7703077225	23
420.5705	50	36.0	7518N8, 7703077225	114

FASTENING CLIPS FOR FIAT

Interior strip clip

- for Fiat
- for Volvo
- in poly bag



Content	Head Ø mm	Length mm	Ø mm	OE		
420.1201	10	16.0	18.0	9.0	4292906	8
420.5201	50	16.0	18.0	9.0	4292906	42

Push-type fastening clip

- for Fiat
- in poly bag



Content	Head Ø mm	Length mm	Ø mm	OE		
420.1202	10	24.0	17.5	9.0	1459487	14
420.5202	50	24.0	17.5	9.0	1459487	72

Push-type fastening clip

- for Fiat
- in poly bag



Content	Head Ø mm	Length mm	Ø mm	OE		
420.1203	10	18.0	22.0	9.0	1300433650	13
420.5203	50	18.0	22.0	9.0	1300433650	65

Fastening clip

- for Fiat
- in poly bag

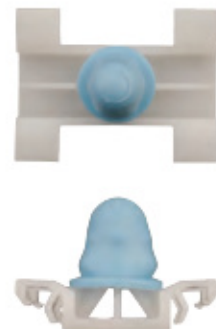

Content	Width mm	Length mm	OE		
420.1204	10	27.0	17.0	71717421	32
420.5204	50	27.0	17.0	71717421	162

Trim clip

- for Fiat
- in poly bag



Content	Head Ø mm	Length mm	Ø mm	OE		
420.1205	10	18.3	21.5	7.7	82456515	16
420.5205	50	18.3	21.5	7.7	82456515	80

Trim clip

- for Fiat
- in poly bag



Content	Head Ø mm	Length mm	Ø mm	OE	Icon
420.1206	10	18.1	21.4	5757139	9
420.5206	50	18.1	21.4	5757139	43

Interior strip clip

- for Fiat
- in poly bag



Content	Head Ø mm	Length mm	Ø mm	OE	Icon
420.1207	10	25.2	18.0	1459387	11
420.5207	50	25.2	18.0	1459387	55

Trim clip

- for Fiat
- in poly bag



Content	Head Ø mm	Length mm	Ø mm	OE	Icon
420.1208	10	18.5	18.5	14188282, 46306526, 60507749	10
420.5208	50	18.5	18.5	14188282, 46306526, 60507749	51

Trim clip

- for Fiat
- in poly bag



Content	Head Ø mm	Length mm	Ø mm	OE	Icon
420.1209	10	19.8	18.0	14591687	13
420.5209	50	19.8	18.0	14591687	67

Trim clip

- for Fiat
- in poly bag



Content	Head Ø mm	Length mm	Ø mm	OE	Icon
420.1210	10	19.7	22.6	1452387	11
420.5210	50	19.7	22.6	1452387	54

Screw grommet

- for Fiat
- in poly bag



Content	Head Ø mm	Length mm	Ø mm	OE	Icon
420.1211	10	12.3	18.0	83468473	14
420.5211	50	12.3	18.0	83468473	68

Fastening clip

- for Fiat
- in poly bag



Content	Head Ø mm	Length mm	Ø mm	OE	Icon
420.1212	10	13.9	10.9	7677865	4
420.5212	50	13.9	10.9	7677865	21

UNIVERSAL FASTENING CLIPS ALSO FOR FIAT

Insert connection clip

- for Citroën/Peugeot
- for Fiat
- for Renault
- in poly bag



Content	Head Ø mm	Length mm	Ø mm	OE	Icon
420.1701	10	16.8	11.0	14188380, 7703077059	7
420.5701	50	16.8	11.0	14188380, 7703077059	36

FASTENING CLIPS FOR FORD

Cable harness fastening

- for Ford
- in poly bag



Content	Head Ø mm	Length mm	Ø mm	OE	Icon
420.1251	10	18.0	20.0	3885775	7
420.5251	50	18.0	20.0	3885775	35

Door strip fastening

- for Ford
- in poly bag



Content	Head Ø mm	Length mm	Ø mm	OE	Icon
420.1261	10	20.0	19.3	N8011925S	9
420.5261	50	20.0	19.3	N8011925S	47

Door and window rubber clip

- for Ford
- in poly bag



Context	Head Ø mm	Length mm	Ø mm	OE	
420.1262	10	5.1	14.5	7,0	N806289S 4
420.5262	50	5.1	14.5	7,0	N806289S 18

Screw

- for Ford
- in poly bag



Context	Head Ø mm	Length mm	Ø mm	OE	
420.1263	10	10.1	10.4	6,3	N379830S 4
420.5263	50	10.1	10.4	6,3	N379830S 22

Push-type clip

- for Ford
- for Nissan
- in poly bag



Context	Head Ø mm	Length mm	Ø mm	OE	
420.1553	10	19.2	12.9	8,0	1007932, 5384401A00 29
420.5553	50	19.2	12.9	8,0	1007932, 5384401A00 143

Trim clip

- for Ford
- in poly bag



Context	Head Ø mm	Length mm	Ø mm	OE	
420.1264	10	24.0	24.1	8,0	N387496S 17
420.5264	50	24.0	24.1	8,0	N387496S 86

Tail light connection clip

- for Ford
- for Opel
- for Chrysler
- in poly bag



Context	Head Ø mm	Length mm	Ø mm	OE	
420.1316	10	7.0	12.1	4,7	16500308, 6500787 4
420.5316	50	7.0	12.1	4,7	16500308, 6500787 19

Cable harness fastening

- for Ford
- in poly bag



Context	Head Ø mm	Length mm	Ø mm	OE	
420.1265	10	11.2	12.3	5,0	N803170S 4
420.5265	50	11.2	12.3	5,0	N803170S 18

Push-type connection clip

- for Ford
- in poly bag



Context	Head Ø mm	Length mm	Ø mm	OE	
420.1266	10	23.2	17.4	9,5	W704958S300 30
420.5266	50	23.2	17.4	9,5	W704958S300 148



Push-type connection clip

- for Ford
- for Mazda
- in poly bag



Context	Head Ø mm	Length mm	Ø mm	OE	
420.1267	10	18.0	18.0	8,0	NAU156145, W706713S300 9
420.5267	50	18.0	18.0	8,0	NAU156145, W706713S300 47

Cable harness fastening

- for Ford
- in poly bag



Context	Head Ø mm	Length mm	Ø mm	OE	
420.1268	10	19.4	12.7	7,1	N388246S 4
420.5268	50	19.4	12.7	7,1	N388246S 21

Connection clip

- for Ford
- in poly bag



Context	Head Ø mm	Length mm	Ø mm	OE	
420.1269	10	19.0	16.0	6,3	N387944S 15
420.5269	50	19.0	16.0	6,3	N387944S 73

Bonnet stripped insulation fastening

- for Ford
- for Mazda
- in poly bag



Context	Head Ø mm	Length mm	Ø mm	OE	QTY
420.1409	10	20.0	9.0	8508197AA, F22Z16774A	3
420.5409	50	20.0	9.0	8508197AA, F22Z16774A	16

Push-type clip

- for Ford
- for Opel
- for Chrysler
- in poly bag



Context	Head Ø mm	Length mm	Ø mm	OE	QTY
420.1254	10	17.8	17.5	10139822, 1673046, 8508197AA	9
420.5254	50	17.8	17.5	10139822, 1673046, 8508197AA	46

Push-type connection clip

- for Ford
- in poly bag



Context	Head Ø mm	Length mm	Ø mm	OE	QTY
420.1271	10	15.8	13.5	N805231S	10
420.5271	50	15.8	13.5	N805231S	52

Connection clip

- for Ford
- in poly bag



Context	Head Ø mm	Length mm	Ø mm	OE	QTY
420.1272	10	10.0	12.0	W705532S300	11
420.5272	50	10.0	12.0	W705532S300	57

Connection clip

- for Ford
- for Mazda
- in poly bag



Context	Head Ø mm	Ø mm	OE	QTY	
420.1260	10	14.0	8.0	B45556741, F1CZ16674A	5
420.5260	50	14.0	8.0	B45556741, F1CZ16674A	25

Push-type connection clip

- for Ford
- in poly bag



Context	Head Ø mm	Ø mm	OE	QTY	
420.1273	10	20.0	8.0	W710250S300	14
420.5273	50	20.0	8.0	W710250S300	72

Mudguard connection clip

- for Ford
- in poly bag



Context	Head Ø mm	Length mm	Ø mm	OE	QTY
420.1904	10	11.2	8.0	W701380SSW	5
420.5904	50	11.2	8.0	W701380SSW	24

Dashboard connection clip

- for Ford
- in poly bag



Context	Head Ø mm	Length mm	Ø mm	OE	QTY
420.1253	10	21.4	29.0	N804379S	22
420.5253	50	21.4	29.0	N804379S	109

Cable harness fastening

- for Ford
- in poly bag



Context	Head Ø mm	Length mm	Ø mm	OE	QTY
420.1252	10	17.6	15.5	6998849	5
420.5252	50	17.6	15.5	6998849	27

Push-type clip

- for Ford
- in poly bag



Context	Head Ø mm	Length mm	Ø mm	OE	QTY
420.1255	10	15.5	22.8	1007932, 8502871	10
420.5255	50	15.5	22.8	1007932, 8502871	50

Bonnet stripped insulation fastening

- for Ford
- for Chrysler
- in poly bag



Content	Width mm	Length mm	Ø mm	OE	
420.1256	10	12.7	40.0	385330, 6003351	13
420.5256	50	12.7	40.0	385330, 6003351	67

Push-type clip

- for Ford
- in poly bag



Content	Head Ø mm	Length mm	Ø mm	OE	
420.1257	10	18.4	10.7	1007932	13
420.5257	50	18.4	10.7	1007932	65

Push-type clip

- for Ford
- in poly bag



Content	Head Ø mm	Length mm	Ø mm	OE	
420.1258	10	18.0	20.5	1070107	9
420.5258	50	18.0	20.5	1070107	46

Insert connection clip

- for Ford
- in poly bag



Content	Head Ø mm	Length mm	Ø mm	OE	
420.1259	10	19.0	20.1	1629279672595	6
420.5259	50	19.0	20.1	1629279672595	29

Boot interior lining clip

- for Ford
- for Volkswagen
- in poly bag



Content	Head Ø mm	Ø mm	OE		
420.1278	10	25.0	8.0	6448410, 6678518	9
420.5278	50	25.0	8.0	6448410, 6678518	46

Door trim clip

- for Ford
- in poly bag



Content	Head Ø mm	Length mm	OE		
420.1279	10	18.5	25.0	1257376	11
420.5279	50	18.5	25.0	1257376	54

Plastic rivet

- for Ford
- in poly bag



Content	Length mm	Ø mm	OE		
420.1274	10	64.2	4.0	N8045835	9
420.5274	50	64.2	4.0	N8045835	45

Plastic rivet

- for Ford
- for Opel
- for Chrysler
- in poly bag



Content	Length mm	Ø mm	OE		
420.1275	10	55.5	6.3	14063981, 6500911, N8030433	18
420.5275	50	55.5	6.3	14063981, 6500911, N8030433	88

Plastic rivet

- for Ford
- in poly bag



Content	Length mm	Ø mm	OE		
420.1276	10	54.0	6.3	6503860, N804675S	19
420.5276	50	54.0	6.3	6503860, N804675S	96

Rivet for headlamp bracket

- for Ford
- in poly bag



Part No.	Centers	Head Ø mm	Length mm	Ø mm	OE	QTY
420.1277	10	15.8	11.1	6.3	383142S	9
420.5277	50	15.8	11.1	6.3	383142S	45

UNIVERSAL FASTENING CLIPS ALSO FOR FORD

Cable harness fastening

- for Ford
- for Volkswagen
- in poly bag



Part No.	Centers	Head Ø mm	Length mm	Ø mm	OE	QTY
420.1852	10	24.3	18.0	7.9	385661, 600334B, N989022	10
420.5852	50	24.3	18.0	7.9	385661, 600334B, N989022	51

Luggage compartment lining clip

- for Ford
- for Honda
- in poly bag



Part No.	Centers	Head Ø mm	Length mm	Ø mm	OE	QTY
420.1358	10	16.0	27.0	6.0	90669SP0003ZA	6
420.5358	50	16.0	27.0	6.0	90669SP0003ZA	29

Bonnet stripped insulation fastening

- for Ford
- for Mazda
- in poly bag



Part No.	Centers	Head Ø mm	Length mm	Ø mm	OE	QTY
420.1409	10	20.0	9.0	6.0	6508197AA, F22Z16774A	3
420.5409	50	20.0	9.0	6.0	6508197AA, F22Z16774A	16

Bumper cover clip

- for Ford
- for Opel
- for Chrysler
- in poly bag



Part No.	Centers	Head Ø mm	Length mm	Ø mm	OE	QTY
420.1307	10	17.9	16.4	7.8	16674629, N806113S	6
420.5307	50	17.9	16.4	7.8	16674629, N806113S	32

Trim clip

- for Ford
- for Opel
- for Chrysler
- in poly bag



Part No.	Centers	Head Ø mm	Length mm	Ø mm	OE	QTY
420.1602	10	18.5	18.3	7.7	1591426, 174864	7
420.5602	50	18.5	18.3	7.7	1591426, 174864	34

Connection clip

- for Ford
- for Mazda
- in poly bag



Part No.	Centers	Head Ø mm	Length mm	Ø mm	OE	QTY
420.1260	10	14.0	10.0	6.0	B4556741, F1CZ16674A	5
420.5260	50	14.0	10.0	6.0	B4556741, F1CZ16674A	25

FASTENING CLIPS FOR HONDA

Front grill clip

- for Honda
- for Mitsubishi
- for Toyota/Lexus
- in poly bag



Part No.	Centers	Width mm	Length mm	Ø mm	OE	QTY
420.1753	10	13.6	21.7		8942180270, 9046712020	7
420.5753	50	13.6	21.7		8942180270, 9046712020	37

Push-type clip

- for Honda
- in poly bag



Part No.	Centers	Head Ø mm	Length mm	Ø mm	OE	QTY
420.1351	10	20.5	20.7	8.0	91502SP0003	24
420.5351	50	20.5	20.7	8.0	91502SP0003	120

Push-type clip

- for Honda
- for Nissan
- in poly bag



Part No.	Centers	Head Ø mm	Length mm	Ø mm	OE	QTY
420.1352	10	20.6	9.5	8.0	75521611000, 90675SB003	13
420.5352	50	20.6	9.5	8.0	75521611000, 90675SB003	63

Trim clip

- for Honda
- in poly bag



Content	Head Ø mm	Length mm	Ø mm	OE	
420.1359	10	17.4	14.2	91566SP0003	10
420.5359	50	17.4	14.2	91566SP0003	52

Bonnet stripped insulation fastening

- for Honda
- in poly bag



Content	Head Ø mm	Length mm	Ø mm	OE	
420.1360	10	6.4	12.0	91513SE003	4
420.5360	50	6.4	12.0	91513SE003	19

Door and window rubber clip

- for Honda
- in poly bag



Content	Head Ø mm	Length mm	Ø mm	OE	
420.1361	10	5.1	10.0	91530ST5003	4
420.5361	50	5.1	10.0	91530ST5003	19

Boot interior lining clip

- for Honda
- in poly bag



Content	Head Ø mm	Length mm	Ø mm	OE	
420.1362	10	15.4	13.4	91550SH3003	10
420.5362	50	15.4	13.4	91550SH3003	50

Screw grommet

- for Honda
- in poly bag



Content	Head Ø mm	Length mm	Screw mm	OE	
420.1363	10	13.3	16.8	91620SR2003	8
420.5363	50	13.3	16.8	91620SR2003	41

Radiator grill clip

- for Honda
- in poly bag



Content	Head Ø mm	Length mm	Ø mm	OE	
420.1364	10	26.0	14.9	91578SV4003	42
420.5364	50	26.0	14.9	91578SV4003	210

Connection clip

- for Honda
- in poly bag



Content	Head Ø mm	Length mm	Ø mm	OE	
420.1365	10	18.1	15.0	38529689A6300	8
420.5365	50	18.1	15.0	38529689A6300	41

Push-type connection clip

- for Honda
- in poly bag



Content	Head Ø mm	Length mm	Ø mm	OE	
420.1366	10	20.0	10.2	91512SX0003	14
420.5366	50	20.0	10.2	91512SX0003	69

Connection clip

- for Honda
- in poly bag



Content	Head Ø mm	Length mm	Ø mm	OE	
420.1367	10	20.1	20.4	906876710030	15
420.5367	50	20.1	20.4	906876710030	77

Push-type connection clip

- for Honda
- in poly bag



Content	Head Ø mm	Length mm	Ø mm	OE	
420.1368	10	15.2	13.8	90683SA5003	8
420.5368	50	15.2	13.8	90683SA5003	41

Connection clip

- for Honda
- for Nissan
- in poly bag



Content	Head Ø mm	Length mm	Ø mm	OE	
420.1369	10	13.2	14.8	01553, 90687SA50030	6
420.5369	50	13.2	14.8	01553, 90687SA50030	29